



WARRANTY REGISTRATION  
[enviro.com/warranty](http://enviro.com/warranty)

# E25/E25I

IPI/NOVA GAS FIREPLACE INSERT

# OWNER'S MANUAL



**WARNING:** If the information in this manual is not followed exactly, a fire or explosion may result causing property damage, personal injury or loss of life. Installation and service must be performed by a qualified installer, service agency or the gas supplier.

# SAFETY PRECAUTIONS

---



## **WARNING:**

### **FIRE OR EXPLOSION HAZARD**

**Failure to follow safety warnings exactly could result in serious injury, death, or property damage.**

- Do not store or use gasoline or other flammable vapors and liquids in the vicinity of this or any other appliance.
  
- **WHAT TO DO IF YOU SMELL GAS**
  - Do not try to light any appliance.
  - Do not touch any electrical switch; do not use any phone in your building.
  - Leave the building immediately.
  - Immediately call your gas supplier from a neighbor's phone. Follow the gas supplier's instructions.
  - If you cannot reach your gas supplier, call the fire department.
  
- Installation and service must be performed by a qualified installer, service agency or the gas supplier.

### **INSTALLER:**

Leave this manual with the appliance.

### **CONSUMER:**

Retain this manual for future reference.

This appliance is only for use with the type of gas indicated on the rating plate. This appliance is not convertible for use with other gases, unless a certified kit is used.

Massachusetts installations (Warning): This product must be installed by a licensed plumber or gas fitter when installed within the Commonwealth of Massachusetts. Other Massachusetts code requirements: Flexible connector must not be longer than 36in., a shut off valve must be installed; only direct vent sealed combustion products are approved for bedrooms/bathrooms. A carbon monoxide detector is required in all rooms containing gas fired direct vent appliances. The fireplace damper must be removed or welded in the open position prior to installation of a fireplace insert.

# SAFETY PRECAUTIONS

## FOR SAFE INSTALLATION AND OPERATION OF YOUR “ENVIRO” HEATER, PLEASE CAREFULLY READ THE FOLLOWING INFORMATION:

- All ENVIRO gas-fired appliances must be installed in accordance with their instructions. Carefully read all the instructions in this manual first. Consult the building authority having jurisdiction to determine the need for a permit prior to commencing the installation.
- **NOTE:** Failure to follow these instructions could cause a malfunction of the fireplace, which could result in death, serious bodily injury, and/or property damage.
- Failure to follow these instructions may also void your fire insurance and/or warranty.

### GENERAL

• Installation and repair should be done by a qualified service person. The appliance should be inspected before the first use and, at least, annually by a qualified service person. More frequent cleaning may be required due to excessive lint from carpeting, bedding material, etc. It is imperative the control compartments, burners and circulating air passageways of the appliance be kept clean.

• Due to high temperatures, the appliance should be located out of high traffic areas and away from furniture and draperies.

**Children and adults should be alerted to the hazards of high surface temperatures and should stay away to avoid burn or clothing ignition.**

• Young children should be carefully supervised when in the same room as the appliance. Toddlers, young children and others may be susceptible to accidental contact burns. A physical barrier is recommended if there are at risk individuals in the house. To restrict access to a fireplace or stove install an adjustable safety gate to keep toddlers, young children and other at risk individuals out of the room and away from hot surfaces. Any safety screen, guard, or barrier removed for servicing an appliance must be replaced prior to operating the appliance.

• Clothing or other flammable materials should not be placed on or near the appliance.

• A barrier designed to reduce the risk of burns from the hot viewing glass is provided with this appliance and shall be installed for the protection of children and other at-risk individuals. If the barrier becomes damaged, the barrier shall be replaced with the manufacturer’s barrier for this appliance

### FOR YOUR SAFETY

• Installation and service must be performed by a qualified installer, service agency or gas supplier.

• This installation must conform to local codes or, in the absence of local codes, with the National Fuel Gas Code, ANSI Z223.1/NFPA 54, or the Natural Gas and Propane Installation Code, CSA B149.1.

• To prevent injury, do not allow anyone who is unfamiliar with the stove to operate it.

**• To prevent injury, if the pilot or pilot and burners have gone out on their own, open the glass door and wait 5 minutes to air out before attempting to re-light the stove.**

• Always keep the area around these appliances clear of combustible material, gasoline and other flammable liquids and vapours.

• These appliances should not be used as a drying rack for clothing or for hanging Christmas stockings/decorations.

• Due to the paint curing on the stove, a faint odor and slight smoking will likely be noticed when the stove is first used. Open a window until the smoking stops.

Always connect this gas stove to a vent system and vent to the outside of the building envelope. Never vent to another room or inside the building. Make sure the specified vent pipe is used, properly sized and of adequate height to provide sufficient draft. Inspect the venting system annually for blockage and signs of deterioration.

**WARNING:** Failure to position the parts in accordance with the diagrams in this booklet, or failure to use only parts specifically approved with this appliance, may result in property damage or personal injury.

**WARNING:** Do not operate with the glass front removed, cracked or broken. Replacement of the glass should be done by a licensed or qualified service person.

• Never use solid fuels such as wood, paper, cardboard, coal, or any flammable liquids, etc., in this appliance.

• Do not use this appliance if any part has been under water. Immediately call a qualified service technician to inspect the appliance and to replace any part of the control system or any gas control which has been under water.

• Do not abuse the glass by striking it or slamming the door shut.

• If the E25 unit is pulled out of its installation, and the vent-air intake system is disconnected for any reason, ensure that the vent-air intake pipes are reconnected and re-sealed in accordance to the instructions noted in INITIAL INSTALLATION - VENTING.

 **DANGER**



**HOT GLASS WILL CAUSE BURNS**  
**DO NOT TOUCH GLASS UNTIL COOLED.**  
**NEVER ALLOW CHILDREN TO TOUCH GLASS.**

A barrier designed to reduce the risk of burns from the hot viewing glass is provided with this appliance and shall be installed for the protection of children and other at-risk individuals.

# TABLE OF CONTENTS

---

Safety Precautions.....	2
Table of Contents.....	4
Codes And Approvals.....	5
Specifications.....	6
Rating Label Location.....	6
Dimensions.....	6
Install Depths.....	6
E25 Options Dimensions.....	6
Operating Instructions.....	7
Lighting and Turning Off Instructions (IPI).....	7
Lighting and Turning Off Instructions (NOVA.).....	8
Remote Control Operations.....	10
System Description.....	10
Technical Data.....	10
Transmitter.....	10
Integrated Fireplace Controller (IFC).....	11
Accessing IFC.....	12
Operating Procedure.....	13
Venturi Adjustment.....	16
Operating Normal operating sounds.....	16
Maintenance And Service.....	17
Glass Door Removal.....	17
Cleaning the Painted Surfaces.....	18
Cleaning the Glass.....	18
Cleaning the Firebox.....	18
Replacing the Glass.....	18
Check Pilot and Burner Flames.....	18
Burner Removal.....	19
Fuel Conversion.....	20
Initial Installation.....	22
Safety Screen & Surround Assembly.....	23
Installing Safety Screen & Surround On unit.....	23
Clearances to Combustibles.....	24
Minimum Fireplace Size.....	24
Venting.....	24
Exhaust Restrictor.....	26
Installing the E25.....	27
Horizontal termination.....	29
Zero Clearance Fireplace Installation.....	30
Electrical-Requirements.....	30
Proflame 2 wiring diagram.....	31
Gas Line Connection.....	32
Adjusting The Pilot Flame.....	33
Secondary Installation.....	31
Log Set Installation.....	34
Trouble Shooting.....	37
Parts Diagram - Components.....	41
Parts List.....	40
Warranty.....	42
Installation Data Sheet.....	43

# CODES AND APPROVALS

**DIRECT VENT:** This type is identified by the suffix DV. This appliance draws all of its air for combustion from outside the dwelling, through a specially designed vent pipe system.

This appliance has been tested and approved for installations from 0 feet to 4500 feet (1372 m) above sea level.

**In the USA:** The appliance may be installed at higher altitudes. Please refer to your American Gas Association guidelines which state: the sea level rated input of Gas Designed Appliances installed at elevations above 2000 (610 m) feet is to be reduced 4% for each 1000 feet (305 m) above sea level. Refer also to local authorities or codes which have jurisdiction in your area regarding the de-rate guidelines.

**In Canada:** When the appliance is installed at elevations above 4500 feet (1372 m), the certified high altitude rating shall be reduced at the rate of 4% for each additional 1000 feet (305 m).

- This appliance has been tested by INTERTEK and found to comply with the established VENTED GAS FIREPLACE HEATER standards in CANADA and the USA as follows:

**DI RECT VENTED GAS FI REPLACE I NSERT HEATER**  
TESTED AND LISTED TO: ANSI Z21.88 / CSA 2.33 VENTED GAS FIREPLACE HEATERS  
CSA 2.17 GAS FIRED APPLIANCES FOR HIGH ALTITUDES  
CSA P.4.1 TESTING METHOD FOR MEASURING ANNUAL FIREPLACE EFFICIENCY

## **This ENVIRO E25 Fireplace Insert:**

- Has been certified for use with either natural or propane gases. (See rating label.)
- Is not for use with solid fuels.
- Is approved for bedroom or bed sitting room. (**IN CANADA:** must be installed with a permanent wall thermostat for bedroom installations. Consult the authority having local jurisdiction in your area. **IN USA:** see current ANSI Z223.1 for installation instructions.)
- Must be installed in accordance with local codes. If none exist, use current installation code CAN/CGA B149 in Canada or ANSI Z223.1/NFPA 54 in the USA.
- Must be properly connected to an approved venting system and not connected to a chimney flue serving a separate solid-fuel burning appliance.
- Is not approved for closet or recessed installations.

**IMPORTANT NOTICE (Regarding first fire up):** When the unit is turned on for the first time, it should be turned onto high without the fan on for the first 4 hours. This will cure the paint, logs, gasket material and other products used in the manufacturing process. It is advisable to open a window or door, as the unit will start to smoke and can irritate some people. After the unit has gone through the first burn, turn the unit off, let the unit get cold then remove the glass door and clean it with a good gas fireplace glass cleaner, available at your local ENVIRO dealer. See "DOOR REMOVAL" and "CLEANING THE GLASS" sections.

## **COLD CLIMATES:**

**NOTE:** In cold climates, additional insulation may be used on some venting. It is recommended in cold climates to wrap the exhaust and intake venting for the final few feet before termination.



# SPECIFICATIONS

## RATING LABEL LOCATION:

The rating label is located in the bottom of the unit.

## DIMENSIONS:

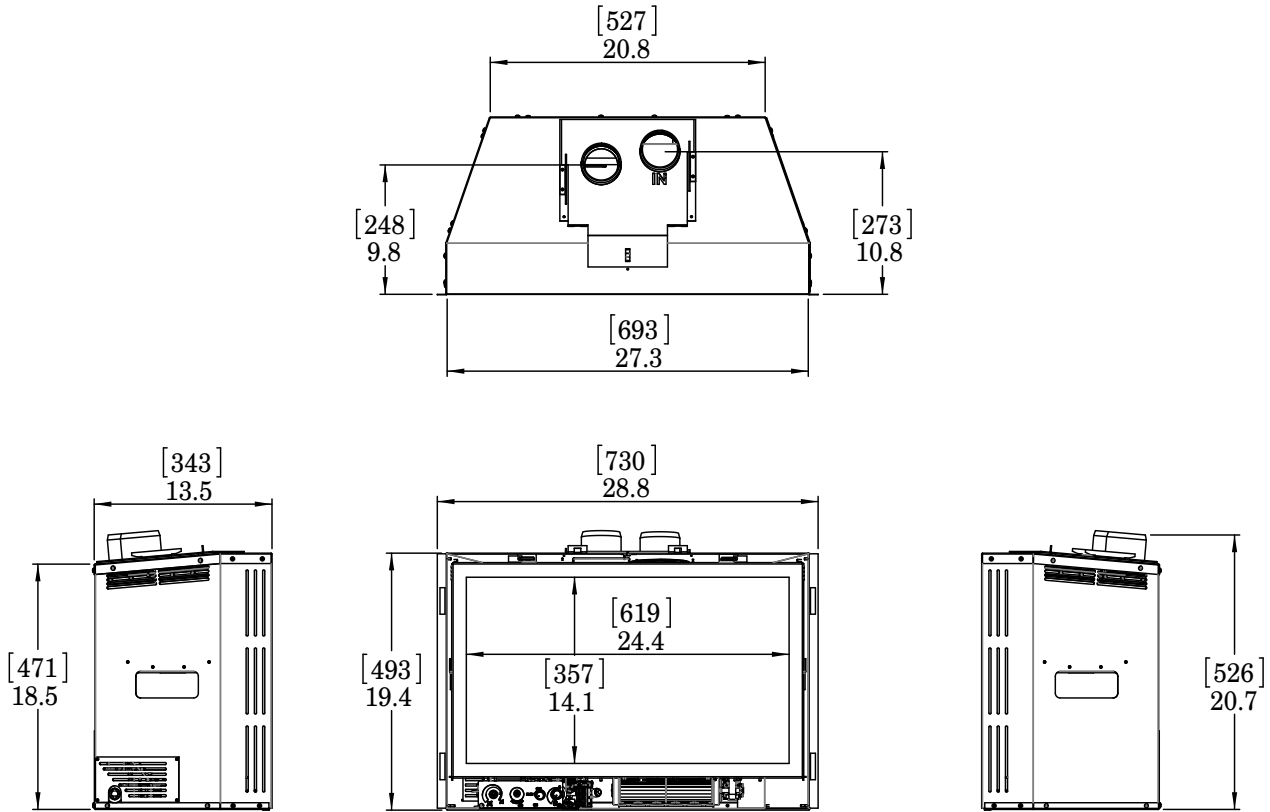

## INSTALL DEPTH:

The E25 has a minimum install depth of 13.5" (343mm).

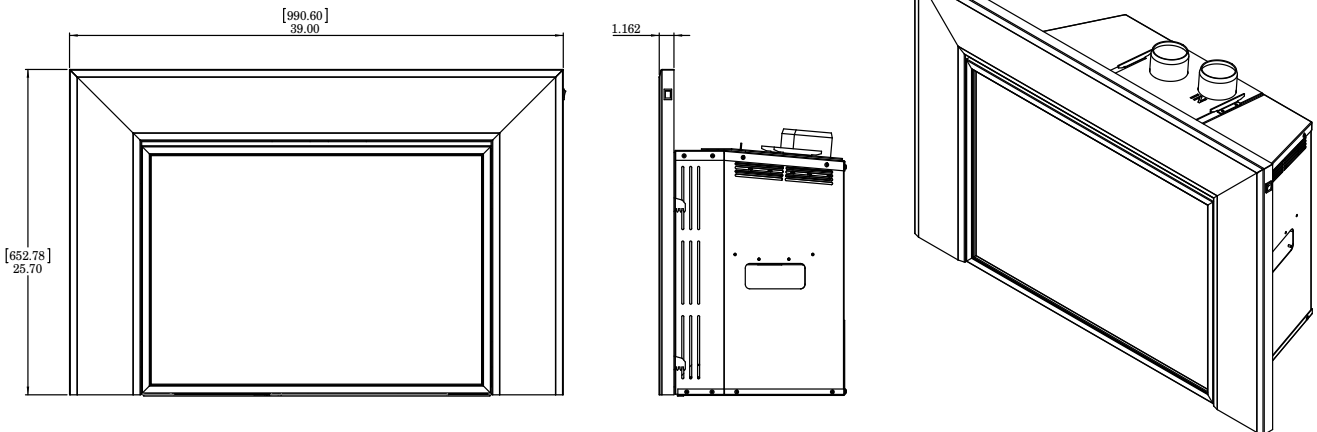

# OPERATING INSTRUCTIONS

**For Your Safety, Read Safety Precautions And Lighting Instructions Before Operating**

**WARNING: IF YOU DO NOT FOLLOW THESE INSTRUCTIONS EXACTLY A FIRE OR EXPLOSION MAY RESULT, CAUSING PROPERTY DAMAGE, PERSONAL INJURY OR LOSS OF LIFE.**

## E25I LIGHTING AND TURNING OFF INSTRUCTIONS:

### FOR YOUR SAFETY READ BEFORE OPERATING

**WARNING:** IF YOU DO NOT FOLLOW THESE INSTRUCTIONS EXACTLY, A FIRE OR EXPLOSION MAY RESULT CAUSING PROPERTY DAMAGE, PERSONAL INJURY OR LOSS OF LIFE.

- A. This appliance is equipped with an ignition device which automatically lights the pilot. Do not try to light the pilot by hand.
- B. BEFORE OPERATING smell all around the appliance area for gas. Be sure to smell next to the floor because some gas is heavier than air and will settle on the floor.
- WHAT TO DO IF YOU SMELL GAS:
- Do not try to light any appliance.
  - Do not touch any electrical switch; do not use any phone in your building.
  - Immediately call your gas supplier from a neighbor's phone. Follow the gas supplier's instructions.
  - If you cannot reach your gas supplier, call the fire department.
- C. Use only your hand to push in or turn the gas control knob. Never use tools. If the knob will not push in or turn by hand, don't try to repair it, call a qualified service technician. Force or attempted repair may result in a fire or explosion.
- D. Do not use this appliance if any part has been under water. Immediately call a qualified service technician to inspect the appliance and to replace any part of the control system and any gas control which has been under water.

### OPERATING INSTRUCTIONS

1. STOP! Read the safety information above on this label.
2. Read the owner's manual including the section on "Remote Control" operation.
3. Set the thermostat to the lowest setting.
4. Turn off all electric power to the appliance.
5. Do not attempt to light the pilot by hand.
6. Wait five (5) minutes to clear out any gas. Then smell for gas, including near the floor. If you smell gas, STOP! Follow "B" in the safety information above on this label. If you don't smell gas, go to the next step.
7. Turn on all electric power to the appliance.
8. Using the remote control, set thermostat to desired setting, or press the ON/OFF key on the remote. "ON" will be indicated on the display of the remote and an audible "beep" will be heard at the unit to indicate the command has been received.
9. This appliance is equipped with a completely automatic ignition and lighting control. The control will attempt to light the pilot several times if necessary. If it is unsuccessful, it will discontinue operations. If the appliance will not operate, follow the instructions "To Turn Off Gas To Appliance" and call your service technician or gas supplier.

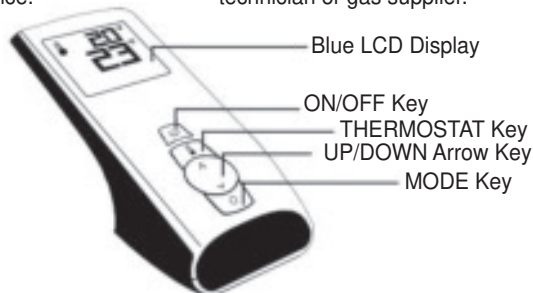

### TO TURN OFF GAS TO APPLIANCE

1. Set thermostat to lowest setting, or press the ON/OFF Key. "OFF" will be indicated on the display and an audible "Beep" will be heard at the unit to indicate the command has been received.
2. Turn off all electric power to the appliance if service is to be performed.

C-12455

# OPERATING INSTRUCTIONS

**For Your Safety, Read Safety Precautions And Lighting Instructions Before Operating**

**WARNING: IF YOU DO NOT FOLLOW THESE INSTRUCTIONS EXACTLY A FIRE OR EXPLOSION MAY RESULT, CAUSING PROPERTY DAMAGE, PERSONAL INJURY OR LOSS OF LIFE.**

## E25 (NOVA) LIGHTING AND TURNING OFF INSTRUCTIONS:

### FOR YOUR SAFETY READ BEFORE LIGHTING



**WARNING:** If you do not follow these instructions exactly, a fire or explosion may result causing property damage, personal injury or loss of life

- A. This appliance has a pilot which must be lighted by hand. When lighting the pilot, follow these instructions exactly.
- B. BEFORE LIGHTING smell all around the appliance area for gas. Be sure to smell next to the floor because some gas is heavier than air and will settle on the floor.
- C. Use only your hand to push in or turn the gas control knob. Never use tools. If the knob will not push in or turn by hand, don't try to repair it. Call a qualified service technician. Force or attempted repair may result in a fire or explosion.
- D. Do not use this appliance if any part has been under water. Immediately call a qualified service technician to inspect the appliance and to replace any part of the control system and any gas control which has been under water.



#### WHAT TO DO IF YOU SMELL GAS:

Do not try to light any appliance. Do not touch any electrical switch; do not use any phone in your building. Immediately call your gas supplier from a neighbor's phone. Follow the gas supplier's instructions. If you cannot reach your gas supplier, call the fire department.

### LIGHTING INSTRUCTIONS

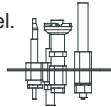
1. STOP! Read the safety information above on this label.
2. Set the thermostat to the lowest setting.
3. Turn off all electric power to this appliance.
4. Open the front control panel.
5. Turn off the gas control knob clockwise  to the "OFF" position.
6. Open door. Wait five (5) minutes to clear out any gas. Close door. Then smell for gas, including near the floor. If you smell gas, STOP! Follow "B" in the safety information above on this label. If you don't smell gas, go to the next step.
7. Find pilot-located near the center rear of the firebox. Turn the gas control knob counter-clockwise  to "PILOT". Push the gas control in fully and hold, keep knob depressed for about 30 seconds after the pilot is lit. Release knob. If pilot goes out, repeat steps 4 through 5.



- WARNING:** This gas valve has a lockout device, which will not allow the pilot burner to be relit until the thermocouple has cooled.
- If the knob does not pop up when released, stop and immediately call your service technician or gas supplier.
  - If the pilot will not stay lit after several tries, turn the gas control knob clockwise  to "OFF" and call your service technician or gas supplier.
8. Turn the gas control knob counter clockwise  to the "ON" position. Flip the burner switch to "ON" then turn the "HI/LOW" knob to the desired setting.
  9. Close the front control panel.
  10. Turn on all electric power to the appliance.
  11. Set thermostat to desired setting.

### TO TURN OFF GAS TO APPLIANCE

1. Set the thermostat to the lowest setting.
2. Turn off all electric power to the appliance if service is to be performed.
3. Open the front control panel and flip burner switch to "OFF"
4. Turn the gas control knob clockwise  to the "OFF" position.
5. Close the front control panel.

C-12454

# OPERATING INSTRUCTIONS

## For Your Safety, Read Safety Precautions And Lighting Instructions Before Operating

### PILOT LIGHT:

1. Turn off the gas to the fireplace. **If not recently done, remove the glass and let the unit air out**

**for at least five (5) minutes to clear out any gas.** Turn on gas to the heater.

2. Turn the gas control knob to pilot, push in and hold

Simultaneously, press the piezo ignitor several times until the pilot ignites. Hold the gas control knob in for at least 30 seconds (Wait for the 3 beeps) once lit. Check that the pilot has fully engulfed the thermocouple assembly. The pilot should now stay lit on its own, release gas control knob.

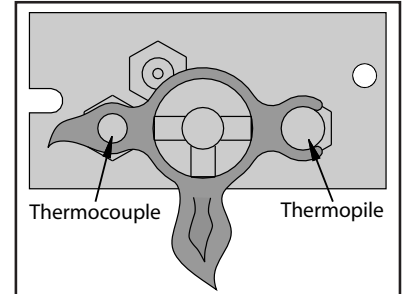

### BURNER LIGHTING:

1. Make sure pilot is lit, if not light it (see above).
2. Turn gas control knob counter-clockwise to ON; if already ON, see next.
3. Flip burner switch to ON.
4. Turn HI/LO control knob to the desired flame height.
5. Check that all burner holes are lit.

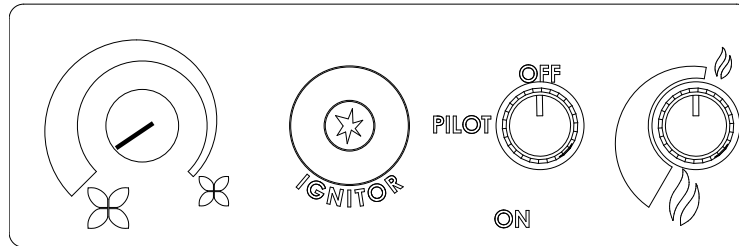

### TO TURN GAS FIREPLACE OFF:

Flip switch to OFF to turn off burners, turn the gas control knob to OFF to extinguish the pilot flame. Keep the pilot flame **OFF** when not in use for long periods. If the fireplace is to be serviced, turn the gas shut off valve OFF (DO NOT FORCE IT) and disconnect all electrical power sources. See (Figure 4) for control panel layout.

**NOTE:** When the unit is turned on for the first time, it should be turned onto high, with the fan OFF for the first two to four hours. This will cure the paint, glass, gasket material, and other products used in the manufacturing process. It is advised that a door or window be opened as the unit will start to smoke, which can irritate some people. After the unit has gone through the first burn, turn the unit OFF, including the pilot, and let the unit get completely cold. Then remove the glass and clean it with a good gas fireplace glass cleaner, available at your local Enviro dealer (See MAINTENANCE AND SERVICE - GLASS DOOR REMOVAL and MAINTENANCE AND SERVICE - CLEANING THE GLASS).

### OPTIONAL BLOWER

Convection fan operation is optional, it will come on only when the fireplace is up to temperature (approximately 15 minutes). The speed of the fan can be changed by turning the fan control knob. The blower will continue to operate automatically after the unit has been shut off (approximately 25 minutes). To turn the blower off, turn the knob counter-clockwise until it "clicks" off

It is advisable not to operate the blower below  $\frac{1}{3}$  speed as it puts a strain on the windings of the blower which could also cause premature fan failure.

# OPERATING INSTRUCTIONS

---

## REMOTE CONTROL OPERATIONS:

---

The Proflame 2 GTMFLSA is a modular remote control system that directs the functions of the E25. The Proflame 2 GTMFLSA is configured to control the on/off main burner operation, its flame levels and provides on/off and Smart thermostatic control of the appliance. The system controls a remotely actuated top light, as well as bottom lights and fan speed each through six (6) levels.

## SYSTEM DESCRIPTION:

---

The Proflame 2 Remote Control System consists of two (2) elements:

1. Proflame 2 Transmitter.
2. Integrated Fireplace Controller (IFC) and wiring harness to connect to the gas valve, stepper motor battery holder, convection fan, and lights.

## ATTENTION!

- TURN "OFF" THE MAIN GAS SUPPLY OF THE APPLIANCE DURING INSTALLATION OR MAINTENANCE OF THE IFC.
- TURN "OFF" MAIN GAS SUPPLY TO THE APPLIANCE PRIOR TO REMOVING OR REINSERTING THE BATTERIES IN THE BATTERY HOLDER

## TECHNICAL DATA

---

### Transmitter (Remote Control):

Supply voltage: 4.5 V (three 1.5 V AAA batteries)

Radio frequency: 315 MHz

### Integrated Fireplace Controller (IFC):

Supply voltage: AC IN - 120 V / 60 Hz

Battery Backup IN - 6 Vdc - 200mA (four 1.5 V AA batteries)

Spark voltage / frequency: >10kV / 1Hz

Comfort modulating fan: 120 V / 60 Hz / 2A

Auxiliary: 120 V / 60 Hz / 5A

## TRANSMITTER:

---

The Proflame 2 Transmitter is a remote control with a blue backlit lcd display. It uses a streamline design with a simple button layout and informative lcd readout. The Transmitter is powered by three (3) AAA type batteries. A Mode Key is provided to Index between the features and a Thermostat Key is used to turn on/off or index through Thermostat functions

# OPERATING INSTRUCTIONS

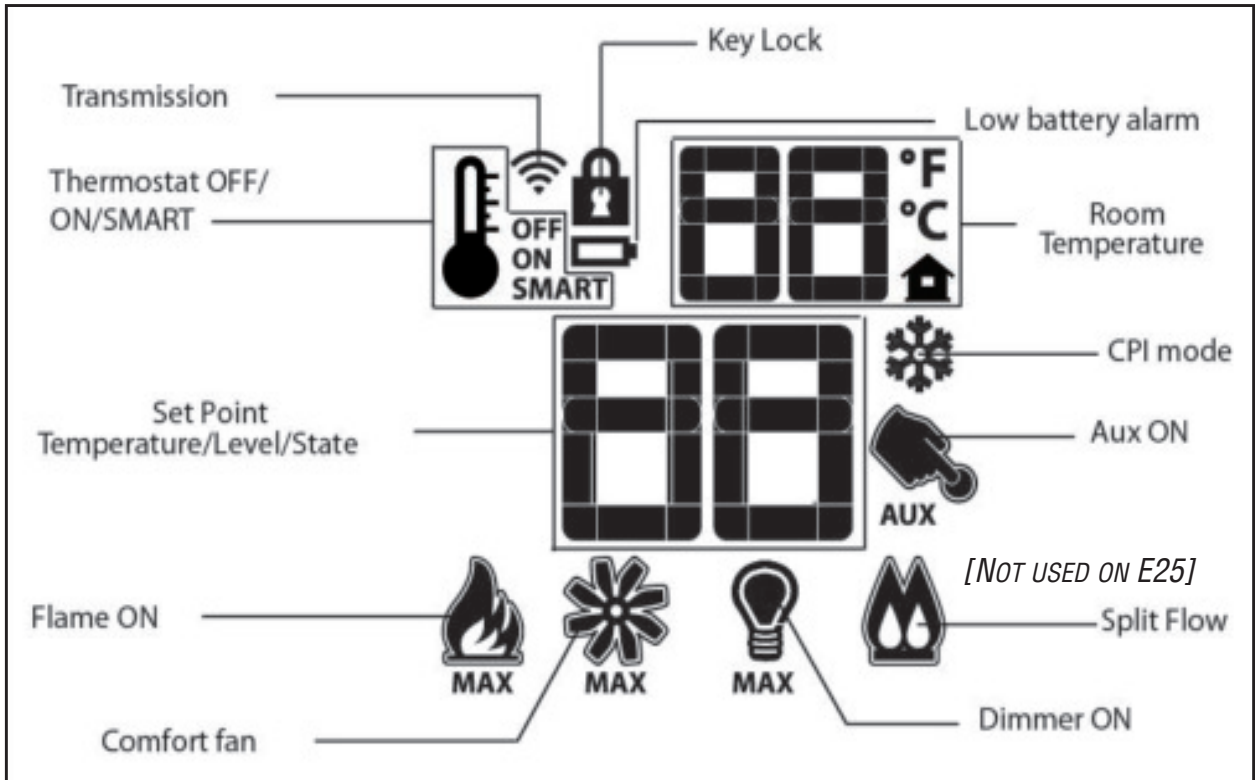

## INTEGRATED FIREPLACE CONTROLLER (IFC):

The Proflame 2 IFC connects directly to the gas valve, stepper motor, pilot, convection fan, and accent lights with wiring harnesses. The IFC is mainly powered by 120 VAC but can also run off a battery backup four (4) AA type batteries for shorter periods of time. The IFC accepts commands via radio frequency from the Transmitter to operate the appliance in accordance with the particular Proflame 2 system configuration. The IFC has a red reset button at the front right corner that is used to synchronize the Transmitter when using the for the first time, or after the batteries have been replaced.

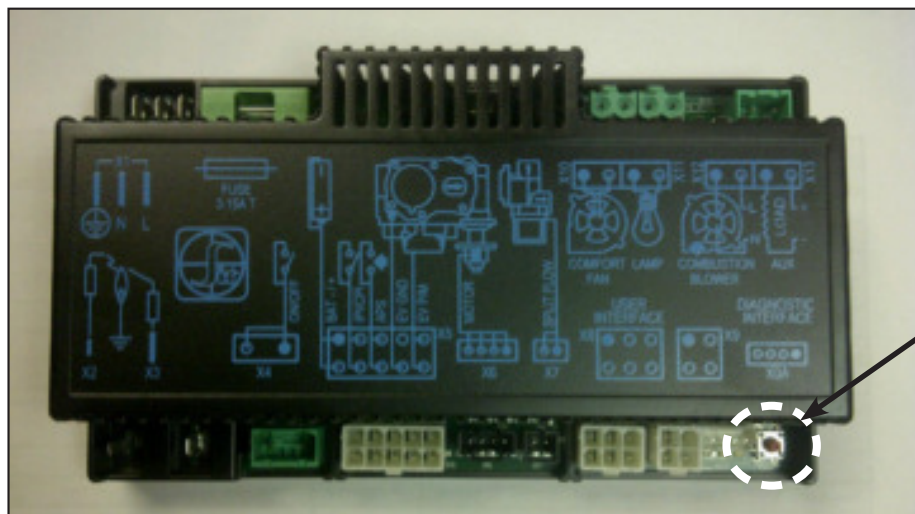

# OPERATING INSTRUCTIONS

## ACCESSING IFC

Due to limited space within the cabinet the IFC & battery pack are located on a sliding tray.

Pull the tray forward out of the cabinet to easily access the battery pack and the IFC. The tray has stops to make sure that the cabling is not over stretched.

If needed you can lift the tray up to remove fully from the unit. When re-inserting the tray back into the unit, there is a cable management clip located at the back of the sliding tray.

ensure the cables are neatly placed under the clip.

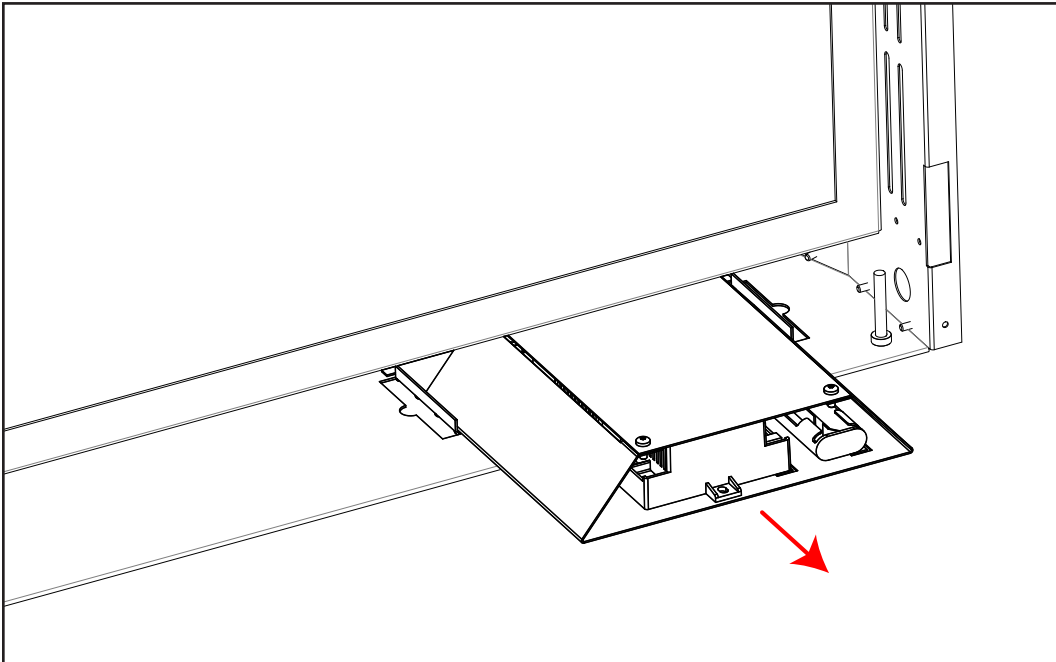

when the tray is fully retracted underneath the unit you need to check that the the wires do not interfere with the fan blades. with the fan is turned on.

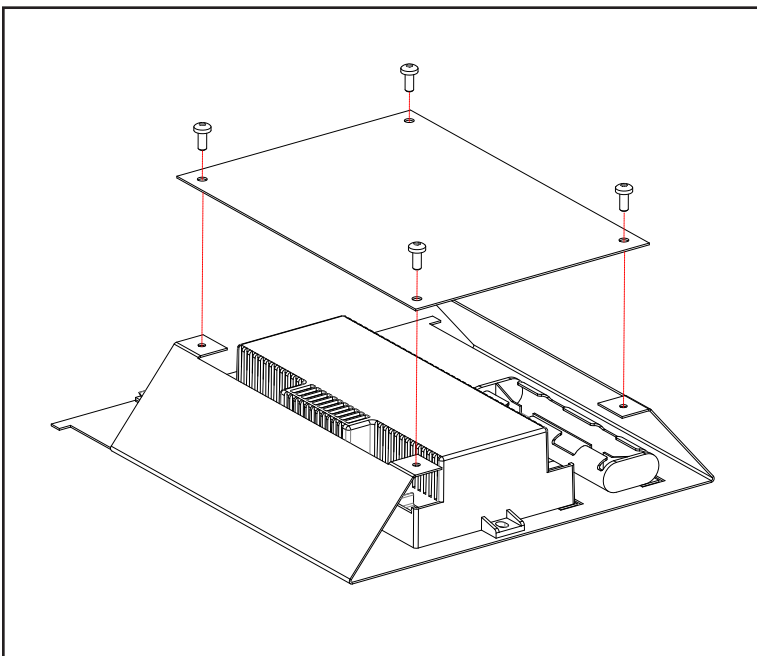

To gain access to the ifc itself. You can remove the 4 fasteners securing the top of the tray.

**You must refasten the tray top to ensure the IFC does not overheat.**

# OPERATING INSTRUCTIONS

## OPERATING PROCEDURE:

### Initializing The System For The First Time

Install the four (4) AA batteries into the IFC battery holder. Note the polarity of the battery and insert into the battery bay as indicated on the body of the battery holder. Press and release the reset button

The IFC will “beep” three (3) times to indicate that it is ready to synchronize with a Transmitter. Install the three (3) AAA type batteries in the Transmitter battery bay, located on the base of the Transmitter. With the batteries already installed in the Transmitter, push the ‘ON’ button. The IFC will “beep” four (4) times to indicate the Transmitter’s command is accepted and sets to the particular code of that Transmitter. The system is now initialized.



### Temperature Indication Display

With the system in the “OFF” position, press the Thermostat Key and the Mode Key at the same time. Look at the LCD screen on the transmitter to verify that a °C or °F is visible to the right of the Room Temperature display (see right)

### Turn on the Appliance

Press the ON/OFF Key on the Transmitter. The Transmitter display will show all active Icons on the screen. A single “beep” from the Receiver will confirm reception of the command and will commence to first ignite the pilot light, followed by the main burner. This should take about 10 seconds to complete.

### Turn off the Appliance

Press the ON/OFF Key on the Transmitter. The Transmitter LCD display will only show the room temperature and Icon (see Figure 9). A single “beep” from the IFC confirms reception of the command and both the pilot light (if the unit is not set to continuous pilot) and main burner will turn off.

### Room Thermostat (Transmitter Operation)

The Remote Control can operate as a room thermostat. The thermostat can be set to a desired temperature to control the comfort level in a room. To activate this function, press the Thermostat Key (see Figure 5). The LCD display on the Transmitter will change to show that the room thermostat is “ON” and the set temperature is now displayed (see Figure 9). To adjust the set temperature, press the Up or Down Arrow Keys until the desired set temperature is displayed on the LCD screen of the Transmitter.

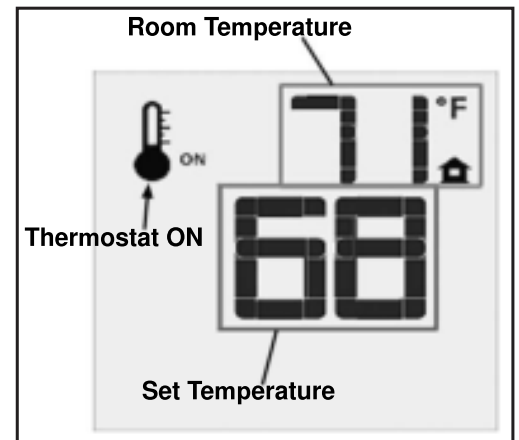

### Smart Thermostat (Transmitter Operation)

The Smart Thermostat function adjusts the flame height in accordance to the difference between the set point temperature and the actual room temperatures. As the room temperature gets closer to the set point the Smart Function will modulate the flame down. To activate this function, press the Thermostat Key until the word “SMART” appears to the right of the temperature bulb graphic. To adjust the set temperature, press the Up or Down Arrow Keys until the desired set temperature is displayed on the LCD screen of the Transmitter.



# OPERATING INSTRUCTIONS

## Remote Flame Control

The Proflame 2 GTMF has six (6) flame levels. With the system on, and the flame level at the maximum in the appliance, pressing the Down Arrow Key once will reduce the flame height by one step until the flame is turned off. The Up Arrow Key will increase the flame height each time it is pressed. If the Up Arrow Key is pressed while the system is on but the flame is off, the flame will come on in the high position. A single "beep" will confirm reception of the command.

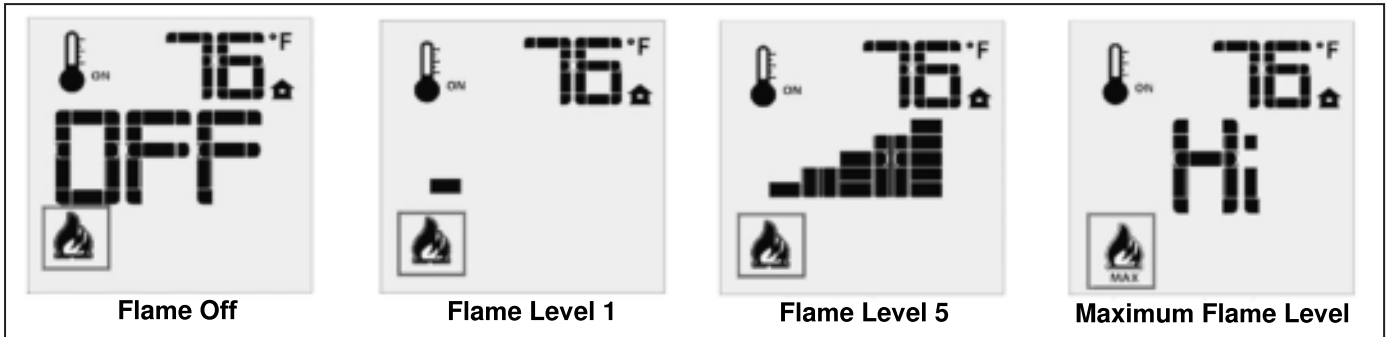

## Fan Control

The E25 comes with a convection fan that can be controlled with the Transmitter. The fan speed can be adjusted through six (6) speeds. To control the fan press the MODE key to index to the fan control icon (Figure 12). Use the UP/DOWN arrow keys to turn on, off, or adjust the fan speed (Figure 12). A single beep from the IFC will confirm the command has been received.

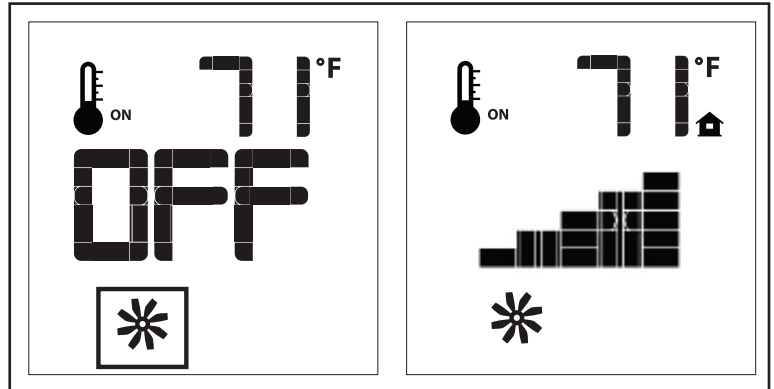

## Split Flow Control

This function is not used on the E25 and can be disregarded.

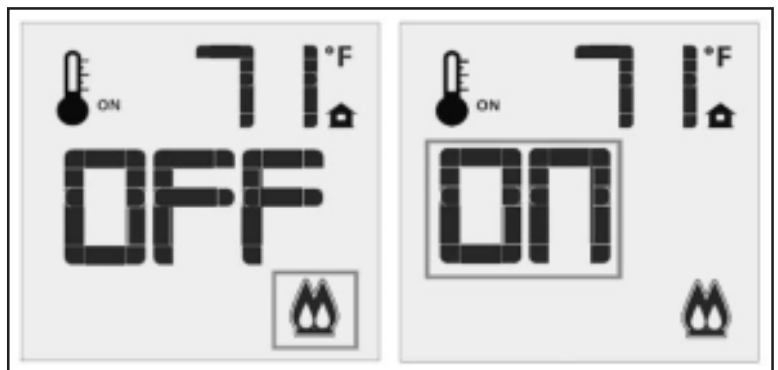

## Key lock

This function will lock the keys to avoid unsupervised operation. To activate this function, press the MODE and UP keys at the same time and the a lock will appear. To de-activate this function, press the MODE and UP Keys at the same time.



# OPERATING INSTRUCTIONS

## Low Battery Power Detection

**Transmitter:** The life span of the remote control batteries depends on various factors: quality of the batteries used, the number of ignitions of the appliance, the number of changes to the room thermostat set point, etc. When the Transmitter batteries are low, a Battery Icon will appear on the LCD display of the Transmitter before all battery power is lost. When the batteries are replaced this Icon will disappear.



**IFC:** The life span of the IFC batteries depends on various factors during a prolonged power outage: quality of the batteries used, the number of ignitions of the appliance, the number of changes to the room thermostat set point etc. When the IFC batteries are low, No "beep" will be emitted when it receives an On/Off command from the Transmitter. This is an alert for a low battery condition for the IFC. When the batteries are replaced the "beep" will be emitted from the Receiver when the ON/OFF Key is pressed (See INITIALIZING THE SYSTEM FOR THE FIRST TIME).

## Switching to Continuous Pilot Mode

When the fireplace is turned off press the mode key to index to the constant pilot (CPI) mode icon Pressing the up arrow key will select Continuous Pilot Ignition (CPI) and pressing the down arrow key will return to IPI. Once a selection is made the IFC will beep once to confirm it had received the command. **NOTE: It is recommended to use the continuous pilot mode during the winter when the outside temperature is below 50°F (10°C) to keep the chimney properly heated for updraft during burner ignition.** Continuous pilot mode also keeps the firebox warm which eliminates both heat loss to cold air that is trapped inside the firebox as well as excessive exhaust vapour condensation on the door glass.

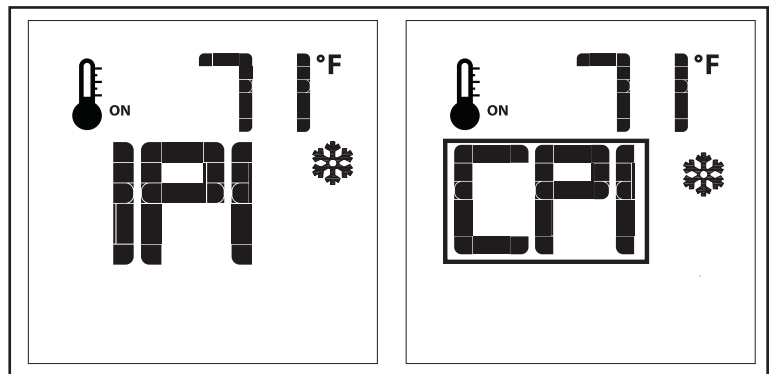

*NOTE: USE OF CPI PILOT MODE NOT PERMITTED IN BC OR AB*

**WARNING: Fire Hazard. Can cause severe injury or death. The IFC causes ignition of the appliance. The appliance can turn on suddenly. Keep away from the appliance burner when operating the remote system.**

**WARNING: Shock Hazard. Can cause severe injury or death. This device is powered by line voltage. Do not try to repair this device. In no way is the enclosure to be tampered with or opened. Disconnect from line voltage before performing any maintenance.**

**CAUTION: Property Damage Hazard. Excessive heat can cause property damage. The appliance can stay lit for many hours. Turn off the appliance if it is not going to be attended for any length of time. Always place the Transmitter where children cannot reach it.**

# OPERATING INSTRUCTIONS

## VENTURI ADJUSTMENT:

The venturi adjustment slider is located in the centre of the unit, below the door (see Figure 4).

The venturi allows the amount of air coming into the fireplace to be adjusted in order to accommodate different climates and venting arrangements. Start the pilot and then the burner. Make sure the pilot flame is burning normally and none of the burner ports are plugged. Let the fireplace burn for roughly fifteen (15) minutes and then examine the flames. The ideal flame will be blue at the base and light

orange above. The flames should be of medium height. If the flames look like this, no venturi adjustment is needed. If the flames are fairly short and mostly blue, the fireplace is getting too much air. Therefore, the air shutter should be closed (push right) slightly until the correct flames are achieved. Flames that are very orange, with tall dark stringy tips are not getting enough air. Open (push left) the venturi until the flames clean up. If the venturi is opened, then closed all the way, and the correct flames cannot be attained, turn off the gas and contact the dealer.

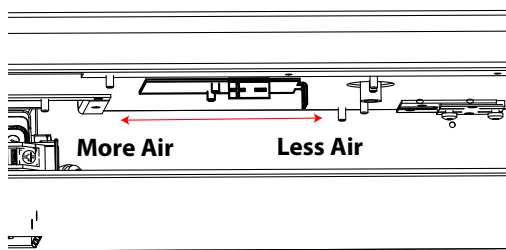

**Warning:** Incorrect venturi adjustment may lead to improper combustion, which is a safety hazard. Contact the dealer if there is any concern about the venturi adjustment.

## NORMAL SOUNDS DURING OPERATION:

Component	Sound & Reason
Fire Box	Creaking when heating up or cooling down.
Burner	Light pop or poof when turned off; this is more common with LP units.
Pilot Flame	Quiet whisper while the pilot flame is on.
Blower / Fan	Air movement that increases and decreases with the speed of the blower.
Gas Control Valve	Dull click when turning on or off, this is the valve opening and closing.
IFC	Beeps when remote control buttons are pressed.

# MAINTENANCE AND SERVICE

**Warning:** Failure to position the parts in accordance with this manual, or failure to use only parts specifically approved with this appliance, may result in property damage or personal injury.

At least once a year, run through the following procedures to ensure the system is clean and working properly. Check the burner to see if all the ports are clear and clean. Check the pilot to make sure it is not blocked by anything. The pilot flame should be blue with little or no yellow on the tips.

The venting system must be periodically examined; it is recommended the examination is done by a qualified person.

## GLASS DOOR REMOVAL:

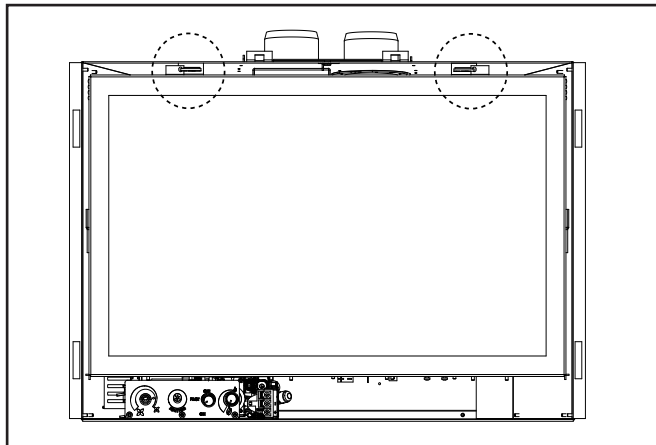

*Door Spring Latch Locations*

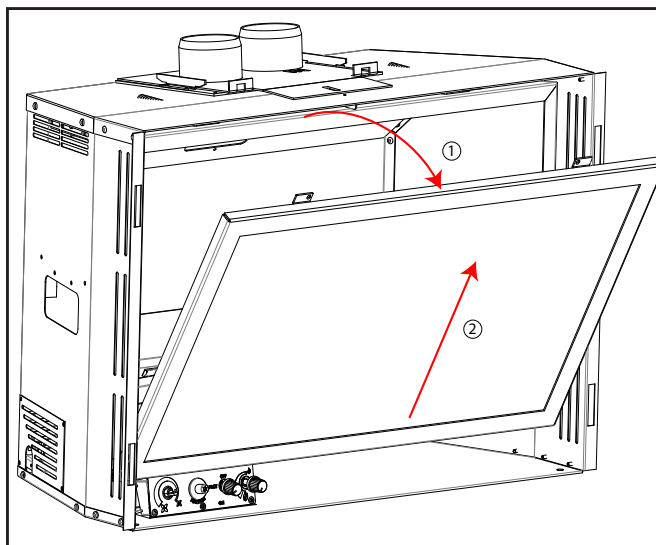
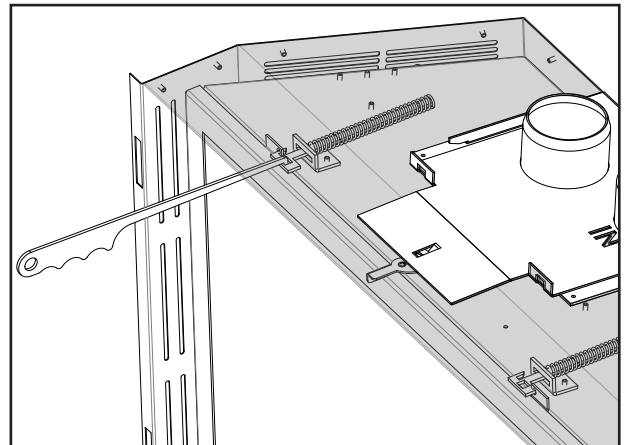

*Door Removal*

The glass door of the fireplace is retained at the top by two spring latches as shown above left. Release the latches by placing the hooked end of the door tool in the hole on the door latch mechanism (see above) and pulling the latch forward then out to the side. When the two (2) latches have been released, tilt the top of the door forward and lift up to remove the door (left) To re-install the glass door simply reverse the procedure.

**Warning:** Do not touch or attempt to remove the glass if the fireplace is not completely cool.  
**Never operate the fireplace with the glass removed.**

CAUTION GLASS MAY SEPARATE FROM DOOR.

# MAINTENANCE AND SERVICE

---

## CLEANING THE PAINTED SURFACES:

---

Painted surfaces should be periodically wiped with a damp cloth when the unit is cool.

## CLEANING THE GLASS:

---

**When the fireplace is cool**, remove the glass door. See MAINTENANCE AND SERVICE - GLASS DOOR REMOVAL. Check the gasket material on the back of the glass, making sure that it is attached and intact.

During a cold start up, condensation will form on the glass. This is a normal condition with all fireplaces. However, this condensation can allow dust and lint to cling to the glass surface. Initial paint curing of the appliance can leave a slight film on the glass. The glass will need cleaning after the fireplace has cooled off from the first burn and about two weeks after first burn. **Use a mild glass cleaner and a soft cloth. Abrasive cleaners will damage the glass and painted surfaces.** Depending on the amount of use, the glass should require cleaning no more than two or three times a season. **Do not clean the glass when it is hot.**

## CLEANING THE FIREBOX:

---

Remove the logs carefully, as they are very fragile. Gently remove all the embers and rock wool and place on a paper towel. Vacuum the bottom of the firebox thoroughly. Carefully clean any dust off the logs and remove any lint from the burner and pilot. At this time, inspect the burner tube for cracking or severe warping. If a problem is suspected, contact the dealer. Check the logs for deterioration or large amounts of soot; a small amount on the logs is normal. Replace the logs and embers as in the SECONDARY INSTALLATION - LOG SET AND EMBER INSTALLATION section. If new/more embers and rock wool are required, contact your nearest ENVIRO dealer.

## REPLACING THE GLASS:

---

The glass in the fireplace is a high temperature ceramic. If the glass is damaged in any way, a factory replacement is required (see PARTS LIST). Wear gloves when handling damaged glass door assembly to prevent personal injury. Do not operate with the glass front removed, cracked or broken. Removal and replacement of the glass from the door **must** be done by a licensed or qualified service person. **The glass must be purchased from an ENVIRO dealer. No substitute materials are allowed.** Remove the door (see page 16). The replacement glass will come with a new gasket installed. Remove any silicone remnants from the door. Apply high temperature silicone to the two vertical faces of the door and install the new piece of glass with gasket (be sure to maintain edge clearances). Apply even pressure to the glass to allow the silicone to adhere to the gasket material.

## CHECK PILOT AND BURNER FLAMES:

---

Periodically do a visual check of the pilot flames. One flame should encompass the flame sensor and the other should burn over the burner ports. Also check that the burner is operating correctly, refer to Venturi Adjustment section.

# MAINTENANCE AND SERVICE

## BURNER REMOVAL:

The burner may need to be removed for a few reasons, including cleaning under the burner, converting the unit to a different gas type, or to replace the burner altogether. Proceed only when the unit has completely cooled down.

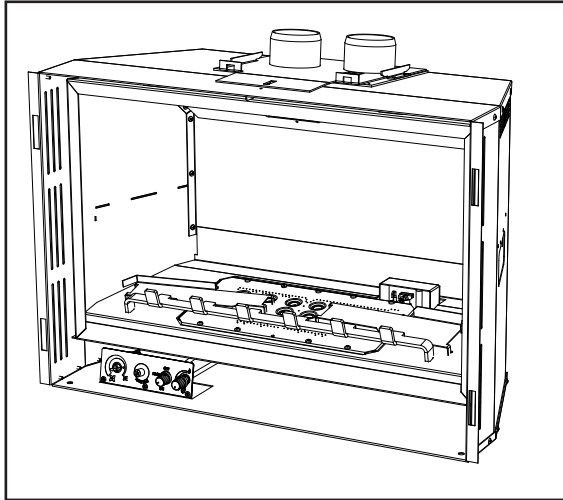

**1.** Open door and remove logs from fireplace.

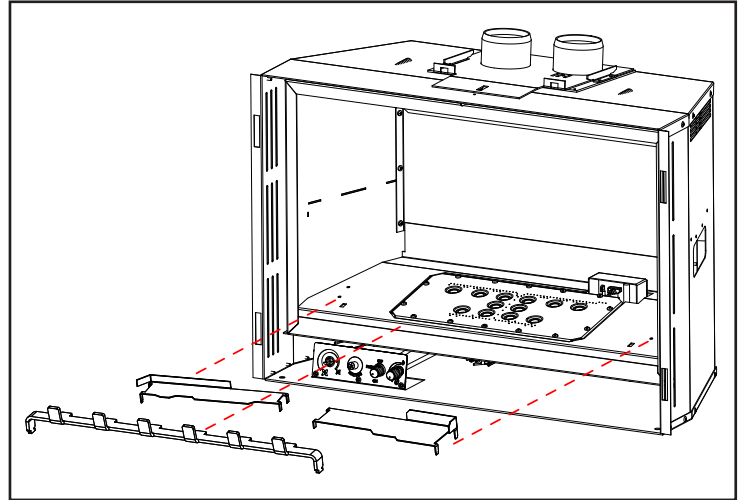

**2.** Remove log stands and log grate. Be careful not to scratch the paint when removing from fireplace.

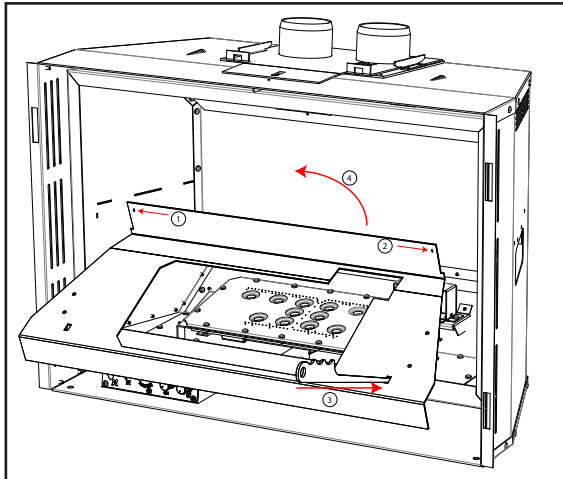

**3.** Unscrew the fasteners holding the log deflector tray.

**4.** Insert hook end of door opening tool into slot in used for the log grate.

**5.** Rotate rear of tray forward and remove log deflector tray.

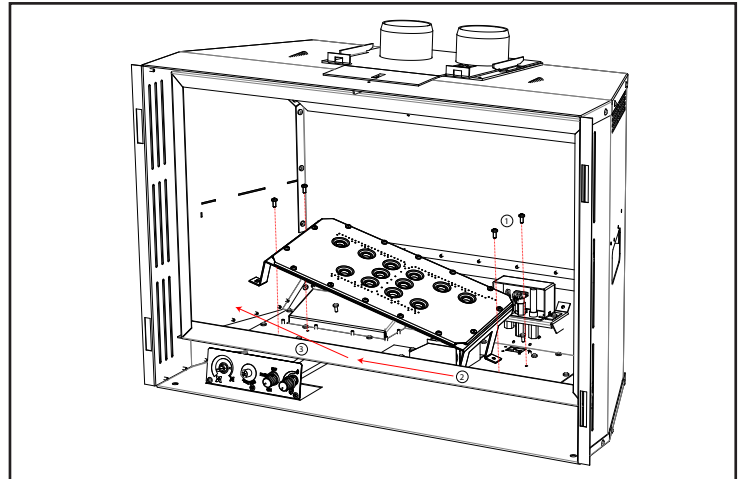

**6.** Unscrew the 4 fasteners holding down the burner and burner mount. Slide burner and mount to the left.

**7.** Lift out burner and mount together.

# E25i & E25 Gas fuel Conversion Instructions

**Warning:** This conversion kit shall be installed by a qualified service agency in accordance with the manufacturer's instructions and all applicable codes and requirements of the authority having jurisdiction. If the information in these instructions is not followed exactly, a fire, explosion or production of carbon monoxide may result causing property damage, personal injury or loss of life. The qualified service agency is responsible for the proper installation of this kit. The installation is not proper or complete until the operation of the converted appliance is checked as specified in the manufacturer's instructions supplied with the kit.

**CAUTION-** The gas supply shall be cut off prior to disconnecting the electrical power, before proceeding with the conversion.

## NG to LP parts list

50-3981

- 52 bullet orifice
- 1 x Rating Plate Conversion Label
- 1 x Valve Body Conversion Label
- Stepper Motor For IPI (ordered Separately) (50-3753)

## LP to NG parts list

50-3982

- 38 bullet orifice
- 1 x Rating Plate Conversion Label
- 1 x Valve Body Conversion Label
- Stepper Motor For IPI (ordered Separately) (50-3870)

1. Remove door
2. Carefully remove logs, log stands and log grate from firebox. Place aside for re-installation.
3. Insert door tool into slot used for log grate lift up and rotate out log deflector (show left)
4. Using a T20 screwdriver remove the x4 screws holding down the burner mount.
5. Slide burner and burner mount to the left. Lift out burner and burner mount together.

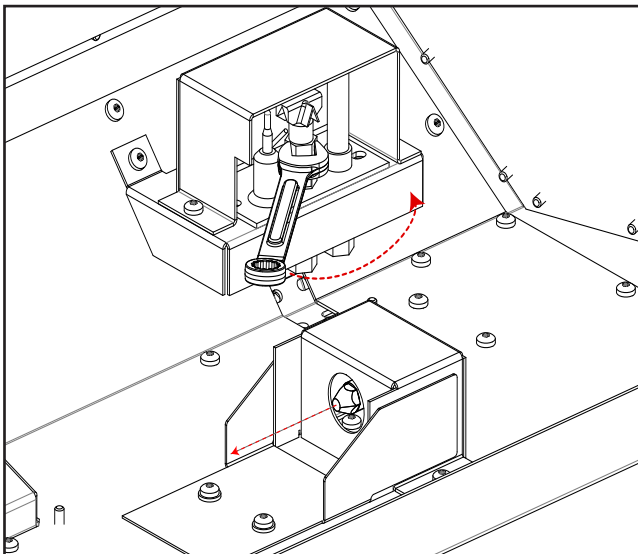

6. Using a 3/8" socket remove the installed orifice.
7. Insert new orifice and tighten.
8. Using a 7/16" wrench loosen the pilot thread by turning it 1/4 turn to the counterclockwise.
9. Once loosened push the slider to the desired gas type. The gas type is written on the top of the slider.  
Left to LP Right to NG

10. Re-tighten pilot head with 1/4 turn to the clockwise.

# NOVA SPECIFIC INSTRUCTIONS

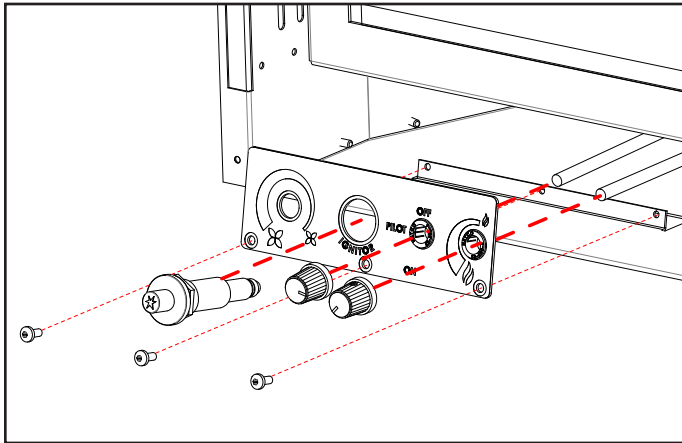

**1.** To gain access to the valve you will need to remove the front control panel. Remove the Qty-3 T20 screws holding the control panel on.

**2.** Rotate the knobs to expose the set screws. Using a small flat head screwdriver loosen set screw and remove knobs

**3.** Pull the control panel forward to expose the rear of the panel and undo the nut securing the ignitor.

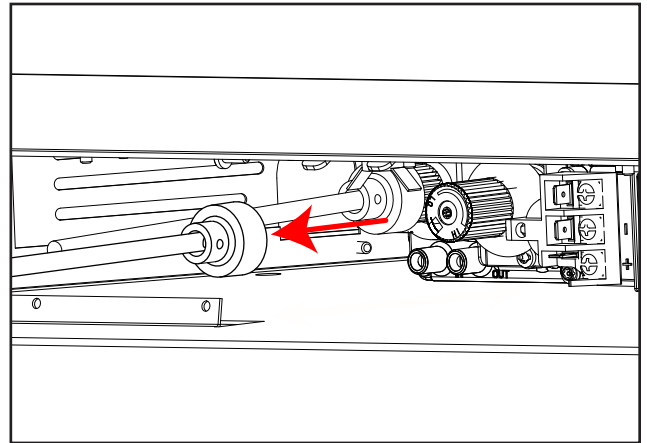

**4.** The valve is located in the rear left corner of the unit. You will need to remove the rod and cap from the control knob on the valve itself. The caps are held on with a small amount of silicone.

Pull rod and cap off of the valve. Removing valve cap.

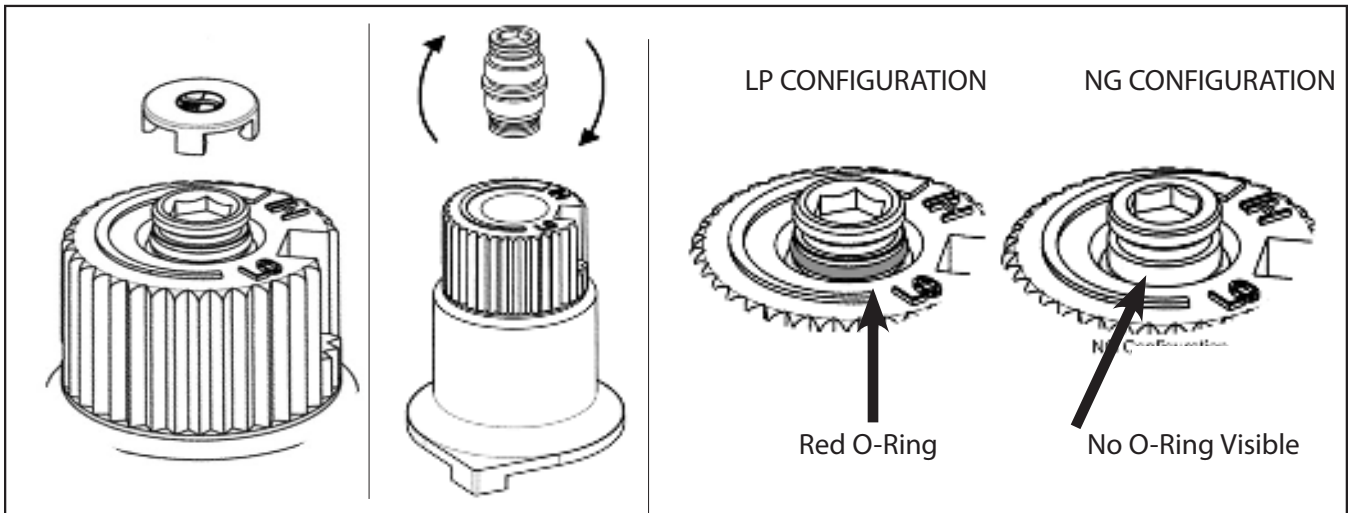

**5.** Insert a 5/32" or 4 mm Allen wrench into the hexagonal key-way of the screw rotate it counter-clockwise until it is free and extract it.

**6.** Check that the screw is clean and if necessary remove dirt.

**7.** Flip the screw

**8.** Using the Allen wrench as shown in Figure 2, rotate the screw clockwise until a torque of 9 inch lbs.

**WARNING! Do not over tighten the screw. It is recommended that you grip the wrench by the short side.**

LP CONFIGURATION

NG CONFIGURATION

Red O-Ring

No O-Ring Visible

**9.** Verify that if the conversion is from NG to LPG, the screw must be re-assembled with the red o-ring visible.

If the conversion is from LPG to NG, The red o-ring indicates which fuel the valve is set up for.

# IPI SPECIFIC INSTRUCTIONS

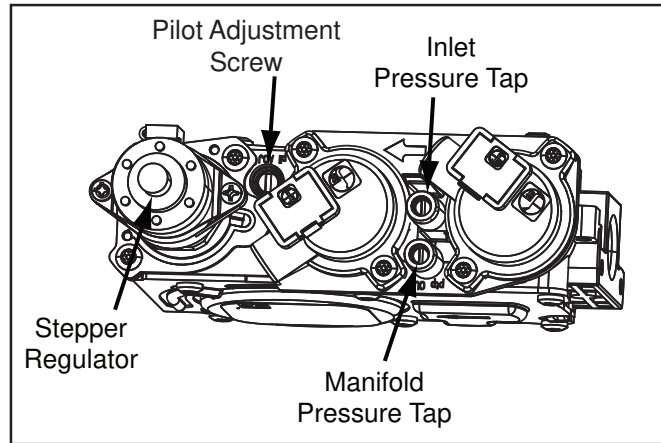
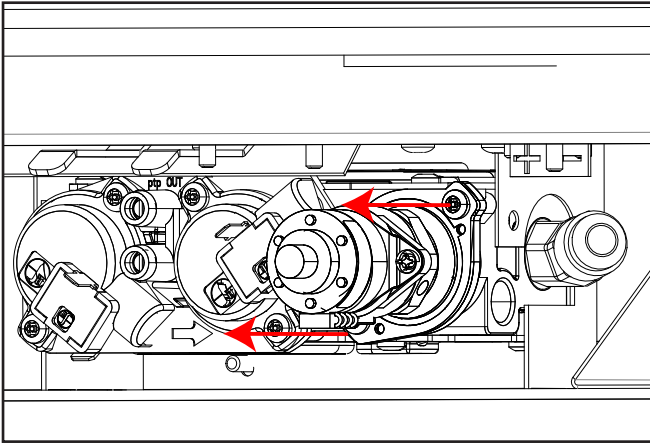

11. 7. Convert the SIT gas valve:
12. Disconnect the wire harness from the IFC.
13. Use a T-20 driver to remove the two screws that hold the servo regulator to the gas valve. Remove the rubber regulator diaphragm that is situated between the servo regulator and the valve body. The New servo regulator already has this diaphragm installed.
14. Install the LP or NG servo regulator, with the new longer T-20 screws included in the kit.
15. Re-connect the harness to the IFC.
16. Reinstall the Burner, burner media and glass door.

## Finalizing Conversion Nova & IPI

1. TESTING FOR LEAKS.
2. Reconnect the electrical power to the unit.
3. 12. Relight the pilot and confirm the flame properly covers both the thermocouple and thermopile. Should the pilot require adjustment, turn the adjustment screw clockwise to decrease or counterclockwise to increase until the
4. Relight the main burner in both the "HI" and "LO" positions to verify proper burner ignition, operation and proper flame appearance.
5. Confirm the inlet and manifold pressures are within the acceptable ranges as directed **See page 41** If the E25 has been installed at an altitude higher than 2000ft (610m) it is required to de-rate the unit accordingly:
6. In the USA: The appliance may be installed at higher altitudes. Please refer to your American Gas Association guidelines which state: the sea level rated input of Gas Designed Appliances installed at elevations above 2000 (610 m)

feet is to be reduced 4% for each 1000 feet (305 m) above sea level. Refer also to local authorities or codes which have jurisdiction in your area regarding the de-rate guidelines.

7. In Canada: When the appliance is installed at elevations above 4500 feet (1372 m), the certified high altitude rating shall be reduced at the rate of 4% for each additional 1000 feet (305 m).

8. 14. MAKE SURE that the conversion label is installed on or close to the rating label to signify that the unit has been converted to a different fuel type.

9. f) Verify that if the conversion is from NG to LPG, the screw must be re-assembled with the red o-ring visible (refer to Figure 4). If the conversion is from LPG to NG, The red o-ring indicates which fuel the valve is set up for

# INITIAL INSTALLATION

**WARNING-** Failure to position the parts in accordance with these diagrams or failure to use only parts specifically approved with this appliance may result in property damage or personnel injury.

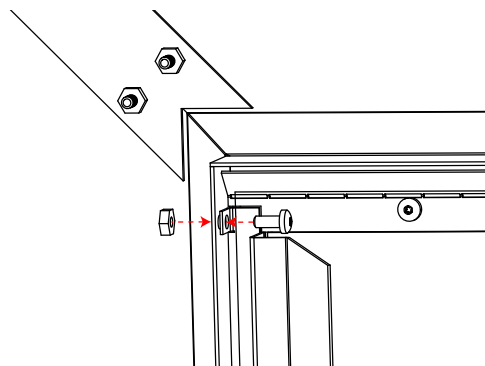
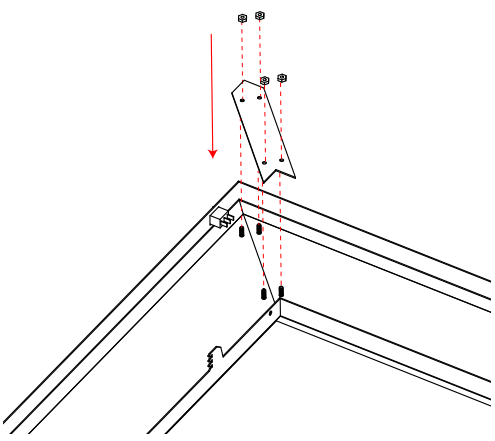
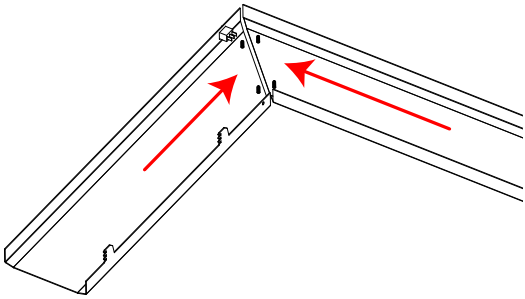
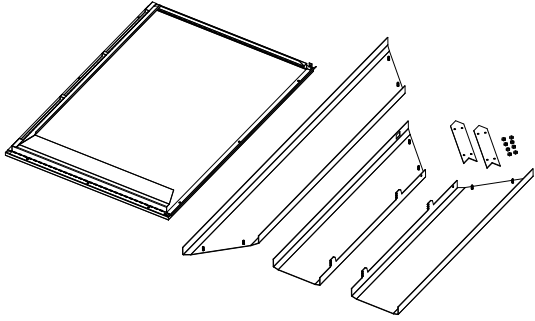

## Safety Screen & Surround Assembly

The surround needs to be assembled on site. you will need a 7/16" socket or wrench.

1. Lay down protective material where you intend to assemble surround. Carefully unwrap all parts making sure not to scratch the paint.
2. Line up surrounds parts aligning the corners
3. Place the Sandwich plate over the studs.
4. Using a 7/16" socket thread the nuts onto the studs. Tighten the nuts down onto the sandwich plate
5. **DO NOT OVERTIGHTEN THE NUTS.**
6. Align the holes on the Safety screen with the holes on the surround sides.
7. Thread the screw through the hole from the safety screen side to the surround side.
8. Thread on the nut to the screw. Do not fully tighten down the nut, as this will hinder the movement of the screen. Leave the nut loose approximately halfway down thread, so the door can swing open.

## Installing safety screen & surround onto unit

the safety screen is attached to the surround and

1. Open the safety screen.
2. Lift safety screen and surround, lining up hooks with slots on the side of the cabinet.
3. Ensure the surround is hooked into the same position on both top and bottom hooks.

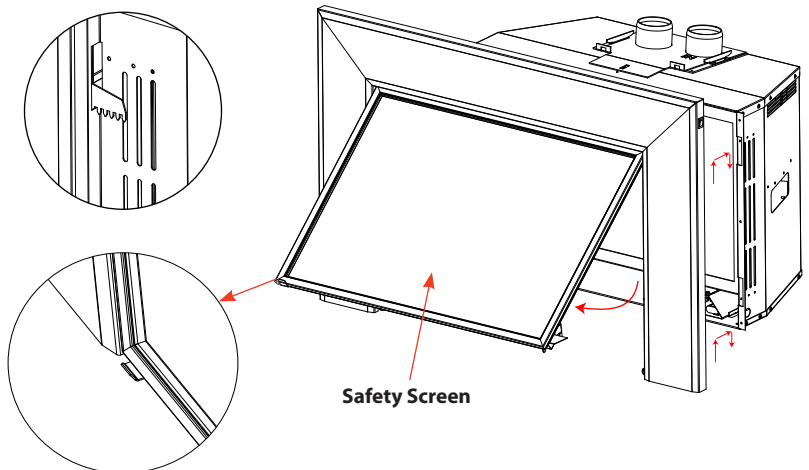

4. The safety screen is hinged to the surround panel. On the bottom left hand side of the safety screen there is a finger pull to allow you to open the safety screen. Please refer to the parts diagram on page 40 for a part numbers if a replacement screen or surround is required.

# INITIAL INSTALLATION

## QUALIFIED INSTALLERS ONLY

**WARNING:** Operation of this heater when not connected to a properly installed and maintained venting system can result in carbon monoxide (CO) poisoning and possible death.

### CLEARANCES TO COMBUSTIBLES:

Maintain sufficient clearances for operation, service and maintenance.

- A minimum distance of 21" (533 mm) is required from the centerline of the unit to the sidewalls.
- Minimum clearance for any combustible facing is 33" (762 mm) from the bottom of the unit.
- A 12" (305 mm) wide mantel can be mounted at a minimum height of 42" (107 cm) from the bottom of unit.
- No floor protection is required for any install height. However it is still strongly recommended to use 12" of floor protection especially when carpet or linoleum flooring are used in front of the insert.
- Unit may be installed with combustible material underneath unit - no spacing required.
- Minimum ceiling clearance is 54" (137 cm) from bottom of unit.

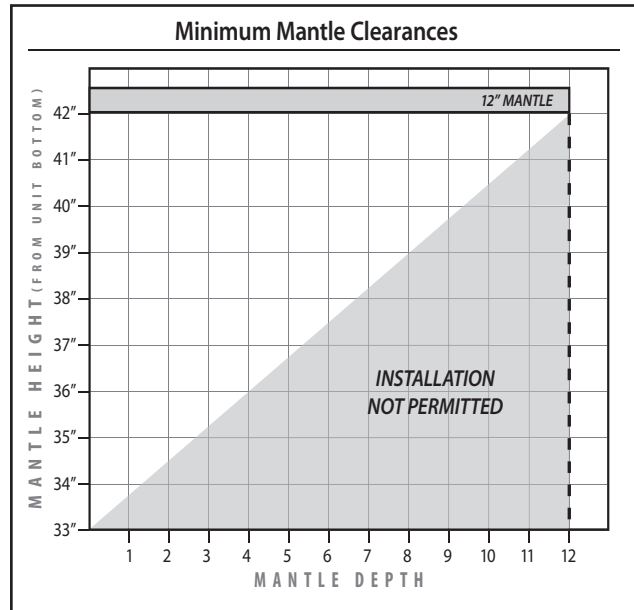

### MINIMUM FIREPLACE SIZE:

**Table 5: Minimum dimensions of fireplace for E25 to be installed into.**

	Width At Front	Width At Back	Height	Depth
Fireplace Dimensions	28" (711 mm)	20.8" (528 mm)	19.5" (495 mm)	13.5" (343 mm)

NOTE: Space must be provided for gas line on left side of unit for servicing purposes.

### VENTING:

**WARNING:** This appliance has been designed to draw room air for proper heat circulation from the sides and bottom of the unit, and out the top front. Blocking or modifying these openings in any way can create hazardous situations.

The vent length for the E25 must be between 10ft (3.05 m) and 40ft (12.2 m).

The E25 intake and exhaust must be connected to 3" dia. flexible venting, made of either aluminum or stainless steel, leading into a vertical termination cap. The flue collars of this model will fit inside of a standard 3" vent and must be fastened directly to the vent with three screws.. The exhaust vent and air intake are both located on the top of the unit.

Check periodically that the vents are unrestricted. Also ensure that all direct vent pipes have been properly sealed and installed after routine inspection or cleaning. The air intake and exhaust pipes must be installed in the correct locations on the top of the E25.

# INITIAL INSTALLATION

## QUALIFIED INSTALLERS ONLY

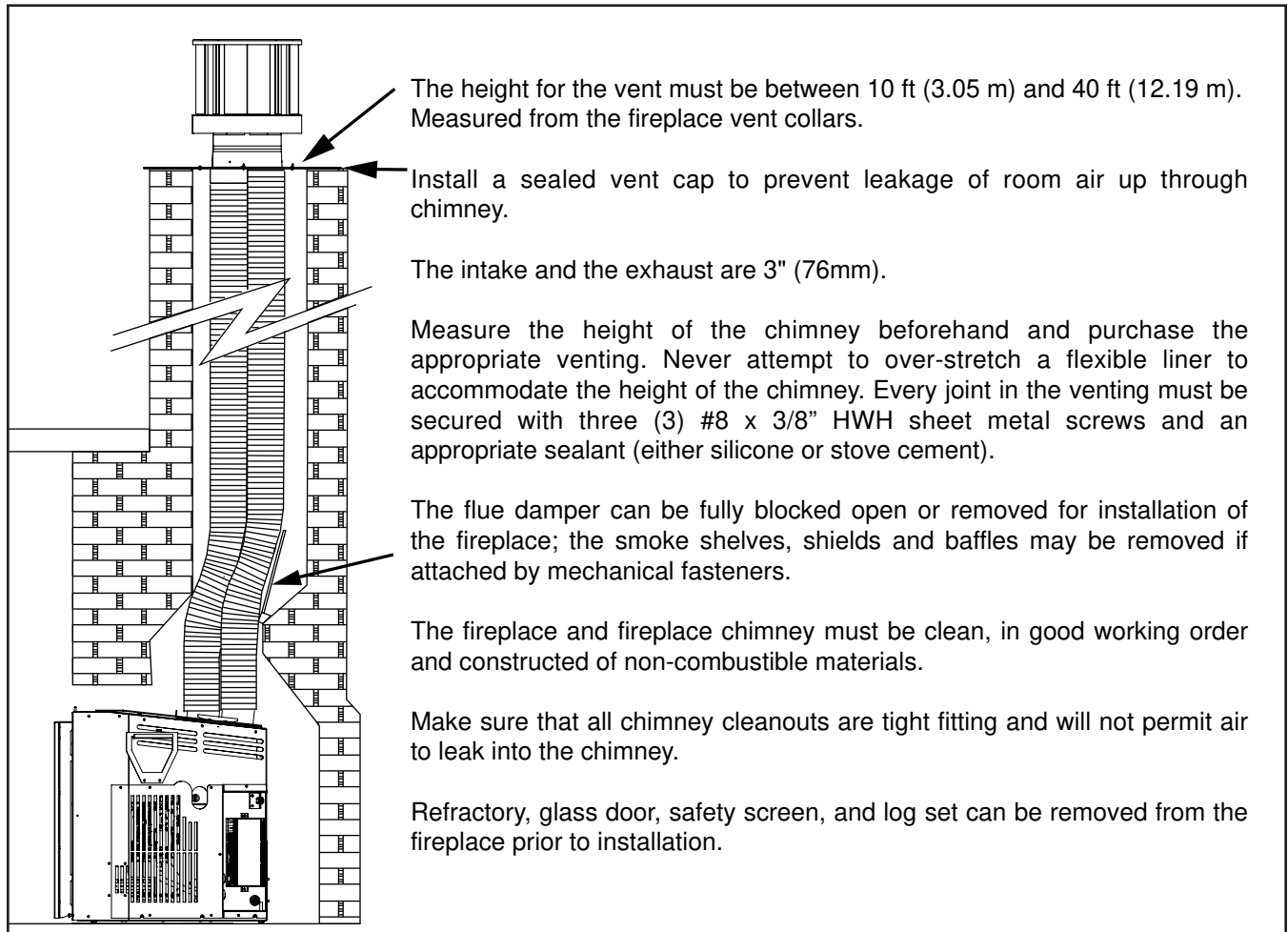

The **ENVIRO** E25 may be installed and vented into any solid fuel fireplace that has been installed in accordance with the National, Provincial/State and local building codes and has been constructed of non-combustible materials. Please reference the information in Table 7 and Figure 28.

An approved chimney liner and rain cap must be used. A throat connector or flashing **must** be installed to ensure a tight seal, top performance, safety and efficiency. Carefully follow the manufacturer's instructions that accompany the chimney liner kit. Use double walled aluminum or stainless steel flex vent from any of the approved brands listed in table 8. If necessary, remove the vent collar plate from the top of the insert and connect it securely to the liner with sheet metal screws.

Check for any tears in the liner at this point. **IMPORTANT:** The screws that hold the vent collar plate in its approved position must be installed.

**NOTE:** If the E25 unit is pulled out of its installation, and the vent air intake system is disconnected for any reason, ensure that the vent-air intake pipes are re-sealed with high-temperature sealant and reconnected with three (3) sheet metal screws evenly spaced.

# INITIAL INSTALLATION

## QUALIFIED INSTALLERS ONLY

### EXHAUST RESTRICTOR:

This fireplace has an internal exhaust restrictor rings. Usage of the restrictor rings is dependant on the length of venting required and different installation requirements.

Use the restrictor rings at your discretion.

Be sure a clean healthy burn is achieved after 15 minutes of burning on High.

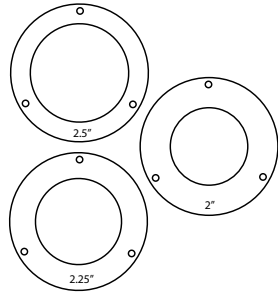

The restrictor rings are installed on the exhaust outlet. The exhaust outlet is accessed from inside of the firebox.

1. Remove door.
2. Undo the fasteners securing baffle.
3. Use the wing nuts provided to secure the restrictor rings to the exhaust outlet.

Note: The E25 comes from the factory without any restrictor rings installed.

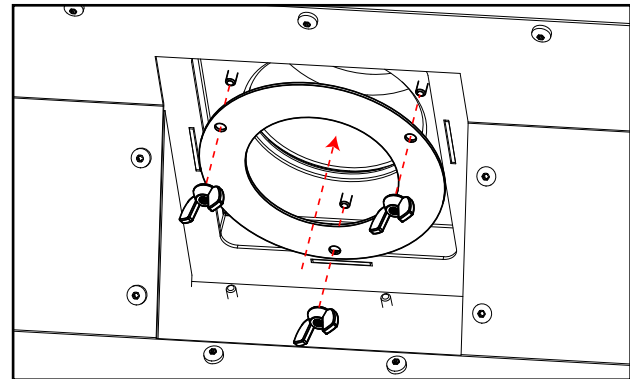
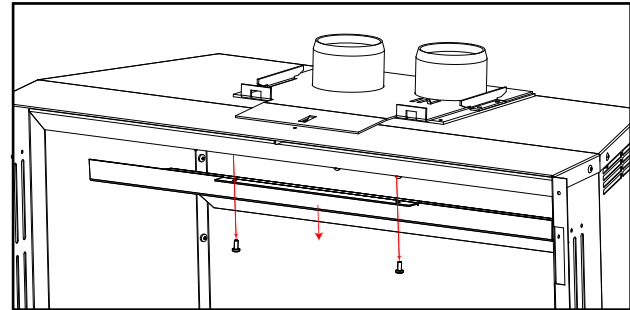

### INSTALLING THE E25:

- Remove the crate and packaging from the appliance and check to make sure there is no damage. Carefully check the glass door. Do not use the unit if it is damaged. In the event damage is found, please report it to your dealer as soon as possible.
- Carefully clean the fireplace and flue before installing the stove. Failure to do so may result in fumes or soot being blown into the room and may cause a fire leading to death or serious injury.

### INSTALLATION INSTRUCTIONS:

1. Plan your installation and clearances to combustibles. The E25 may be installed and vented into any solid fuel fireplace that has been installed in accordance with the National, Provincial/State and local building codes and has been constructed of non-combustible materials. Also refer CLEARANCES TO COMBUSTIBLES section.
2. Remove door. See MAINTENANCE AND SERVICE - GLASS DOOR REMOVAL.

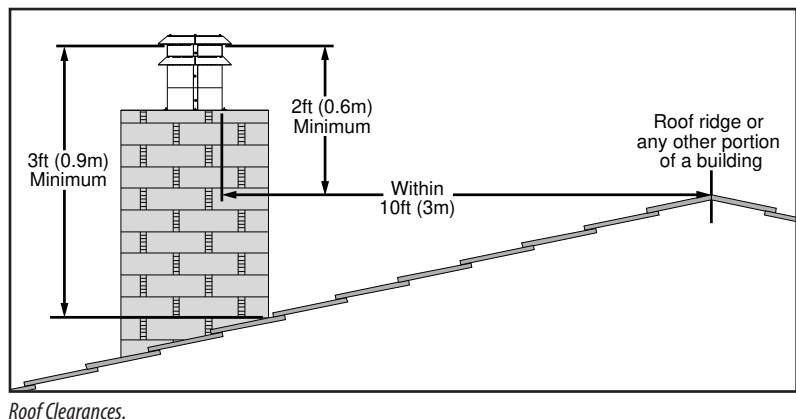

3. Remove packaged log set and all wrapping material from the stove. Remove wrapping material from the log set and check for any damage. If damage is observed, do not use unit and contact your local dealer.

# INITIAL INSTALLATION

## QUALIFIED INSTALLERS ONLY

Minimum Clearance*	Description
3 ft (0.9 m)	Clearance above the highest point where it passes through a roof surface, refer to Figure 23.
24 in (0.6 m)	Clearance above a roof ridge, any other portion of a building, or any other obstruction within a horizontal distance of 10 feet (3 m), refer to Figure 23.
6 ft (1.83 m)	Clearance to mechanical air supply inlet.
3ft (0.9m)	Clearance to each side of center line extended above meter/regulator assembly.
6 ft (1.83 m)	Radial clearance around service regulator vent outlet.
12 in (30 cm)	Clearance above grade, verandah, porch, deck, or balcony.
3 ft (0.9 m)	Clearance to a building opening or combustion air inlet of another appliance, except with the approval of the authority having jurisdiction for the following reduced clearances.
9 in (0.23 m)	Exception for inputs up to and including 50,000 Btu/h (15kW)
12 in (0.3 m)	Exception for inputs exceeding 50,000 Btu/h (15kW) but not exceeding 100,000 Btu/h (30kW)

\*Clearances are in accordance with local installation codes and the requirements of the gas supplier

- Check that the chimney clean outs fit properly. The flue damper must be fully blocked open or removed for installation of the E25; the smoke shelves, shields and baffles may be removed if attached by mechanical fasteners.
- Stretch the Ø3" (76mm) flex vent liners to the length needed to ensure they can be easily connected to the vent terminals.
- Install the flex pipe assembly up through the chimney, ensure that the pipe slides through far enough to connect onto the vent cap. Refer to table 8 to confirm the vent cap is approved for use.
- Most vent caps can be installed onto chimneys with flue openings up to 16" (406mm) x 16" (406mm) when the actual flashing is 16" x 16" or larger. If the chimney is smaller, the flashing should be trimmed down and folded over.
- Apply a bead of stove cement sealant to the Ø3" (76mm) pipe of the exhaust vent terminal. Slide the flex liner onto the vent terminal and secure with three (3) sheet metal screws evenly spaced.
- Place a bead of high temperature silicone on the intake collar of the vent terminal. Slide the Ø3" (76mm) flex intake liner over the collar, secure the flex liner with three (3) sheet metal screws evenly spaced. Secure the vent terminal to the chimney using adequate sealant, and according to local building codes.

Figures. Table 8: Approved Terminations & other parts

	ICC EXCELDirect	M&G DirectVent Pro	Z-Flex
<b>Vertical Termination</b>	TM-SVT*	46DVA-VCH*	See Liner Kit
	TM-IVT		
<b>High-Wind Shield†</b>	TM-SVTS	46DVA-VWG	
<b>Flashing</b>	TF-MFR	46DVA-GK	See Liner Kit
<b>Co-Linear Adapter</b>	TM-CTA		
<b>35' Liner Kit</b>	TM-ALK	46DVA-CL33	2DVI335X
<b>35' Flex Pipe (1 pce.)</b>	TC-øAL35	3DFA-35	

\*Requires co-linear adapter

†Required when installed with minimum vent length

# INITIAL INSTALLATION

## QUALIFIED INSTALLERS ONLY

10. If the fireplace opening is lower than 24" (610 mm), remove the vent collar plate from the top of the insert by unlatching the hook located on the center top of the stove above the door opening (see Figure 29). Slide the collar plate backwards. Properly secure the vent collar plate to the flexible vent pipe liner(s) previously installed in the chimney. Be careful not to over-stretch the liner(s).
11. Apply a bead of stove cement sealant to the top section of the Ø3" (76mm) exhaust vent collar plate. Slide the Ø3" (76mm) flex vent over the flue collar and secure with three (3) sheet metal screws evenly spaced.
12. Place a bead of high temperature silicone on the intake collar of the fireplace, slide the Ø3" (76mm) flex intake liner over the collar, secure the flex liner with three (3) sheet metal screws evenly spaced.
13. Place the unit part way into the fireplace. Connect the gas line to the 3/8" NPT fitting on the right side of the unit using locally approved methods (see INITIAL INSTALLATION - GAS LINE CONNECTION). Route the power cord so it can be connected to the power supply.
14. As you push the unit into its final position in the fireplace, if the vent collar plate was removed, reinstall it on the stove by pulling it into the brackets on top using the supplied tool and latch it back in place (shown in Figure 30).
15. If needed There are 4 bolts in the bag that thread into 4 nuts located in the bottom of the cabinet use the bolts to level the unit.

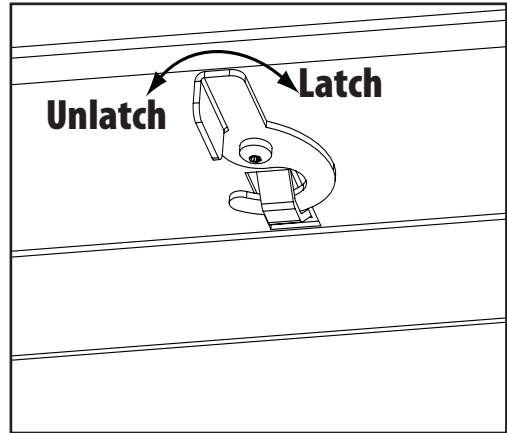

*Vent Collar Plate Latch.*

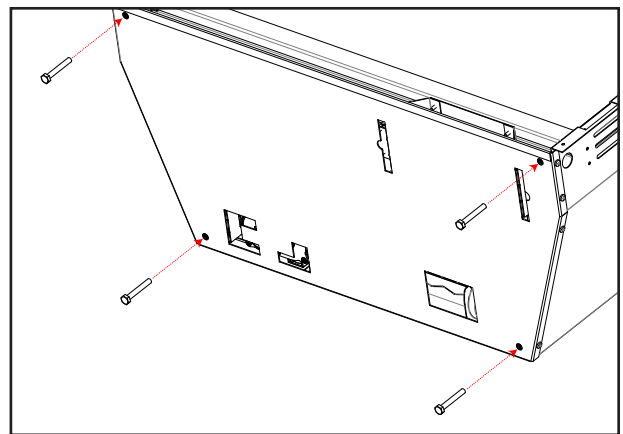
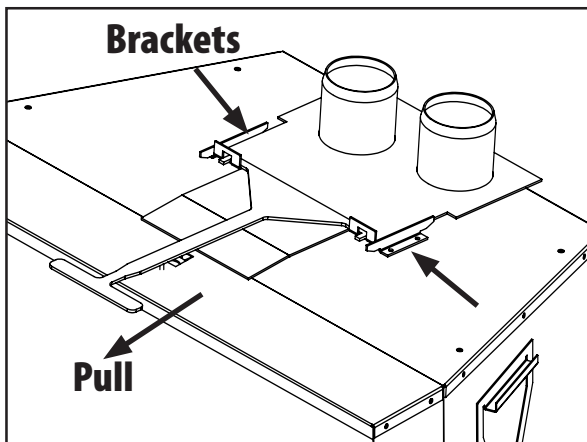

# INITIAL INSTALLATION

## QUALIFIED INSTALLERS ONLY

### Horizontal Termination kits

The E25 is certified for use with:

Duravant - 46DBA-HCL33

ICC - TM-ALH (50-3664)

The minimum height that either horizontal kit can be installed at is 6ft. Horizontal termination Vent Height is Measured from the top of the fireplace cabinet. (Shown in image at bottom of page.) The E25 requires two lengths of 3" flex vent.

#### Step 1:

Remove the Horizontal Vent Kit from the packaging. Ensure there is no damage to the vent piping or termination cap. If there is damage contact your dealer, distributor, or courier company before starting this installation.

#### Step 3:

Proceed to core or drill a hole at the predetermined height. (Use image on right as guide for core cutting)

#### Step 4:

Prebend the intake and exhaust venting, do NOT exceed 90 degrees. After the elbow, stretch the venting to the desired vertical height.

#### Step 5:

Attach the venting to the wall terminal using the supplied hose clamps. Note the exhaust inlet is the inlet with the supplied reducer.

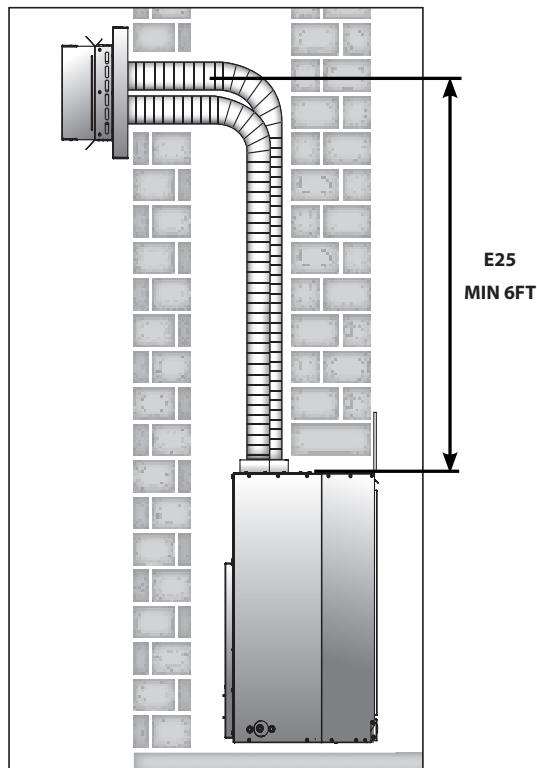

#### Step 2:

Determine the best location on the exterior wall of the chimney for the vent terminal.

Note: A taller vent run will allow for a cleaner burning flame.

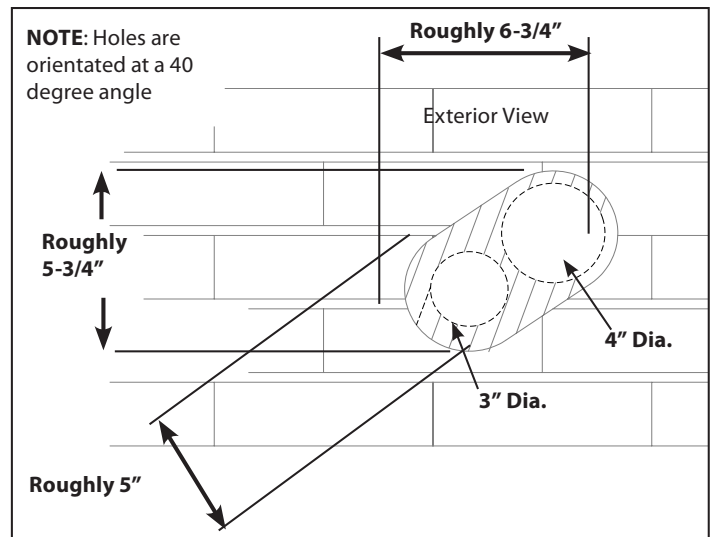

#### Step 6:

Feed the stretched venting into the exterior hole and down the chimney.

Trim any excess vent as needed. Mount the wall terminal to the chimney with screws. Seal as per local codes and regulations.

#### Step 7:

Ensure that the vent length is correct, and the venting is not crimped or overstretched.

#### Step 8:

Attach the venting to the top of the fireplace using 3 screws per vent. Making sure the intake is on the intake collar. The intake collar is indicated on the flue collar of the E series units by the "IN".

# INITIAL INSTALLATION

## QUALIFIED INSTALLERS ONLY Horizontal Termination Clearances

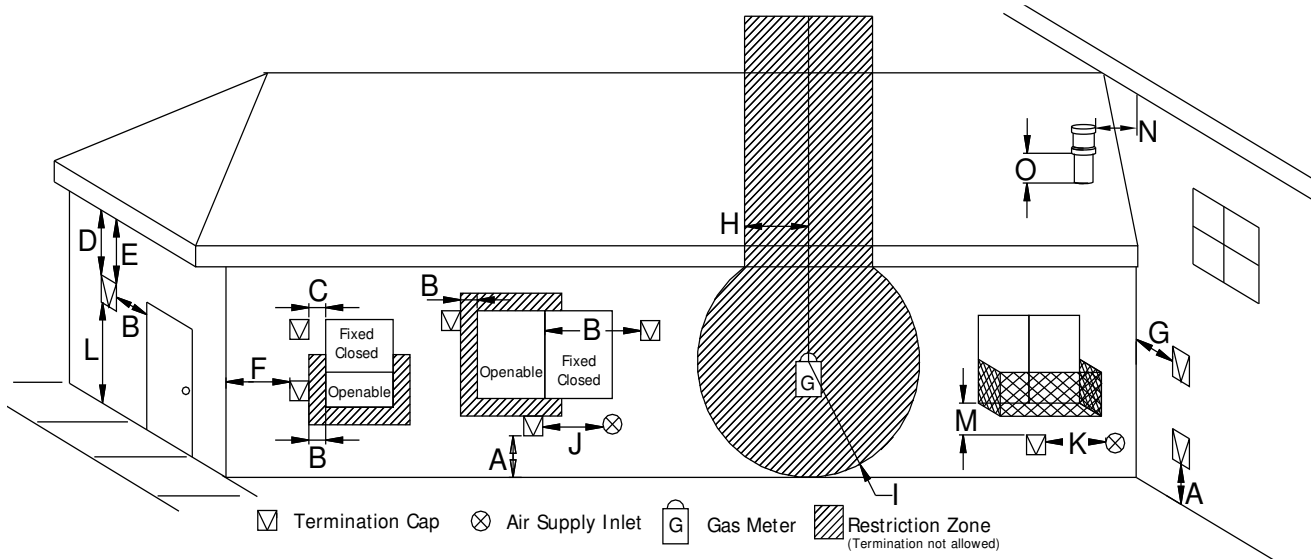

Letter	Canadian Installation <sup>1</sup>	US Installation <sup>2</sup>	Description
A	N/A		Clearance above grade, verandah, porch, deck, or balcony.
B	12 in (30 cm)	9 in (23 cm)	Clearance from window or door that may be opened.
C	12 in (30 cm)*		Clearance from permanently closed window (to prevent condensation).
D	14 in (35.56 cm)		Vertical clearance to ventilated soffit located above the terminal, within a horizontal distance of 2 ft (60 cm) from center line of terminal.
E	14 in (35.56 cm)		Clearance to unventilated soffit.
F	12 in (30 cm)*		Clearance to outside corner.
G	12 in (30 cm)		Clearance to inside corner.
H	3 ft (91 cm) within a height of 15 ft (4.5 m) above the meter/regulator assembly	3 ft (91 cm) within a height of 15 ft (4.5 m) above the meter/regulator assembly*	Clearance to each side of center line extended above meter/regulator assembly.
I	3 ft (91 cm)		Radial clearance around service regulator vent outlet.
J	12 in (30 cm)		Clearance to non-mechanical air supply inlet to building, or the combustion air inlet to any other appliance.
K	6 ft (1.83 m)	3 ft (91 cm) above if within 10 ft (3 m) horizontally	Clearance to mechanical air supply inlet.
L	7 ft (2.13 m) <sup>t</sup>		Clearance above paved sidewalk or paved driveway located on public property.
M	14 in (35.56 cm)		Clearance under verandah, porch, deck, or balcony.
N	N/A		Clearance horizontally to any surface (such as an exterior wall) for vertical terminations.
O	12 in (30 cm)		Clearance above roof line for vertical terminations.

<sup>1</sup> In accordance with the current CSA B149, Natural Gas and Propane Installation Code.

<sup>2</sup> In accordance with the current ANSI Z223.1 NFPA 54, National Fuel Gas Code.

\* These numbers are only estimates.

<sup>t</sup> A vent shall not terminate directly above a side walk or paved driveway that is located between two single family dwellings and it serves both dwellings.

<sup>+</sup> Permitted only if verandah, porch, deck, or balcony is fully open on a minimum of two sides beneath the floor.

Clearances are in accordance with local installation codes and the requirements of the gas supplier.

# INITIAL INSTALLATION

---

## QUALIFIED INSTALLERS ONLY

### ZERO CLEARANCE (ZC) FIREPLACE INSTALLATION:

---

The metal floor of the ZC solid fuel firebox can be removed to allow the installation of the insert. THE CLEARANCE TO COMBUSTIBLE MATERIAL UNDER THE INSERT IS 0" (0 mm). YOU DO NOT NEED TO RAISE THE UNIT OFF OF A COMBUSTIBLE FLOOR. The sidewalls and top structure of the solid fuel firebox cannot be altered with the exception of: removal of dampers, removal of smoke shelf or baffle, removal of ember catches, removal of log grate, removal of viewing screen/curtain, and removal of doors. THE ORIGINAL FIREPLACE MAY NEVER BE RETURNED TO SOLID FUEL USE IN THIS CONDITION.

**IMPORTANT:** If the factory-built fireplace has no gas access hole(s) provided, an access hole of 1.5 inch (37.5 mm) or less may be drilled through the lower sides or bottom of the firebox in a proper workmanship like manner. This access hole must be plugged with non-combustible insulation after the gas supply line has been installed. Cutting any sheet-metal parts of the fireplace, in which the gas fireplace insert is to be installed, except as tested for the floor is prohibited.

The included label plate shown below must be permanently attached inside the cavity of the fireplace in a visible location.

**WARNING: This fireplace has been converted for the use with a gas fireplace insert only and cannot be used for burning wood or solid fuels unless all original parts have been replaced, and the fireplace re-approved by the authority having jurisdiction.**

C-11168

### ELECTRICAL REQUIREMENTS:

---

The fireplace must be electrically connected and grounded in accordance with local codes or, in the absence of local codes, with the current CSA C22.1 Canadian Electrical Code Part 1, Safety Standards For Electrical Installations, or The National Electrical Code ANSI / NFPA 70 in the US.

**WARNING:** The electrical grounding instructions must be followed. The fan kit is equipped with a three-prong (grounding) plug for your protection against shock hazard, and should be plugged directly into a properly grounded three-prong outlet. DO NOT cut or remove the grounding prong from this plug.

**CAUTION:** When servicing controls, label all wires prior to disconnection. Wiring errors can cause improper and dangerous operation. Verify proper operation after servicing.

If any of the original wire as supplied with the appliance must be replaced, it must be replaced with 18 AWG wire with a temperature rating of 105°C

# INITIAL INSTALLATION

QUALIFIED INSTALLERS ONLY

## Proflame 2 System - Wiring Diagram

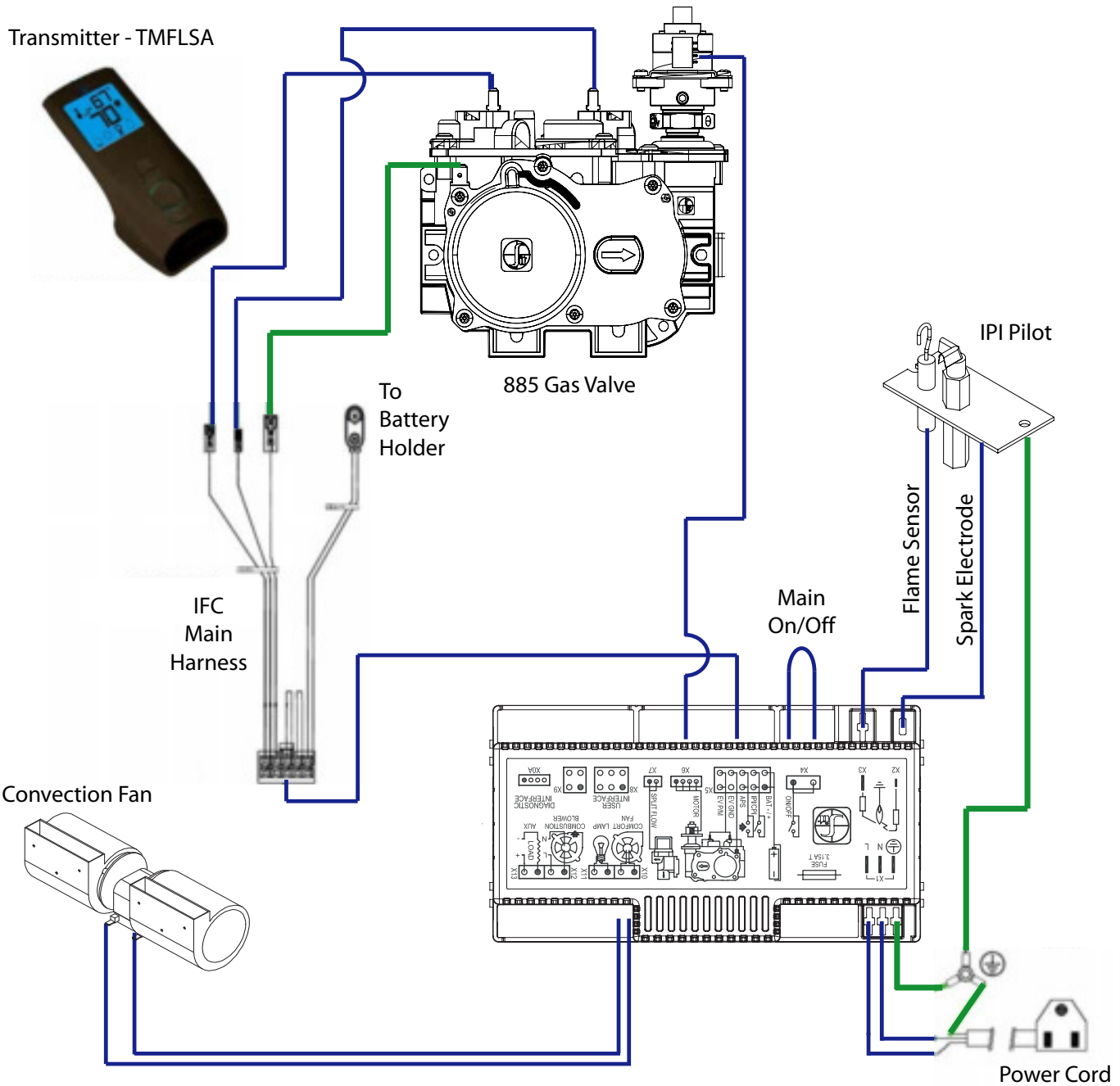

# INITIAL INSTALLATION

## QUALIFIED INSTALLERS ONLY

### GAS LINE CONNECTION:

**WARNING:** Only persons licensed to work with gas piping may make the necessary gas connections to this appliance.

### Gas Line Connection:

- Prior to installation consult your local authorities codes or the CAN/CGA B 149 (1 or 2) installation code in Canada, or in the USA gas installations follow either local codes or the current edition of the National Fuel Gas Code ANSI Z223.1.

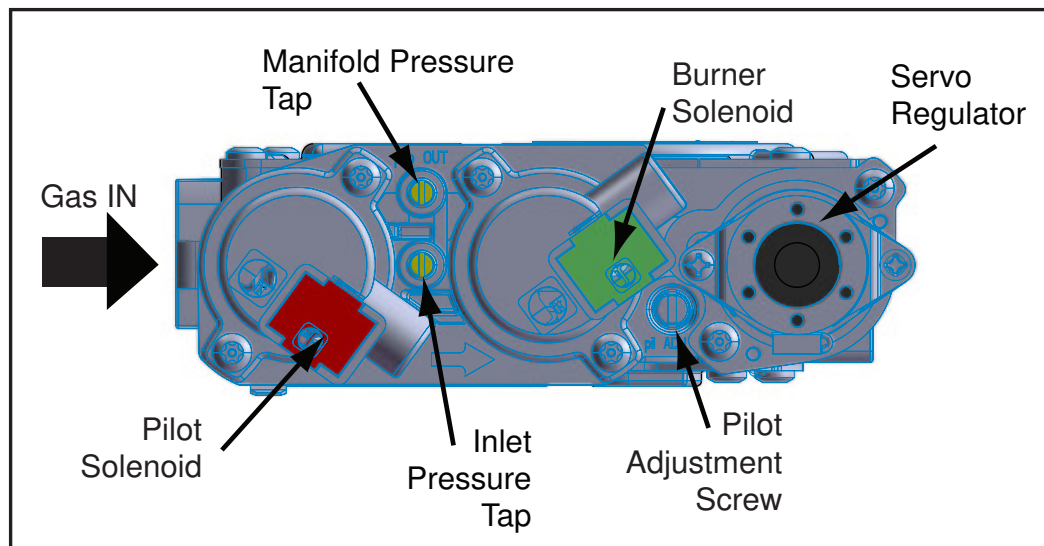

*Fully Labeled Gas Valve.*

The appliance must be disconnected from the gas supply piping system during any pressure testing where the pressure exceeds  $\frac{1}{2}$  PSIG (3.45 KPa) or damage will occur to the valve. The appliance must be isolated from the gas supply piping system by closing its individual manual shutoff valve during any pressure testing of the gas supply piping system at test pressures equal to or less than  $\frac{1}{2}$  psig (3.45 KPa).

**Always check for gas leaks with a soap and water solution after completing the required pressure test.**

### TO TEST VALVE PRESSURES

The pressure taps are located on the valve

- Turn set screw 1 turn counter clockwise to loosen,
- Place  $\frac{5}{16}$ " (8 mm) I.D. hose over pressure tap system.
- Check pressures using a manometer.
- When finished, release pressure, remove hose & tighten set screw.

# INITIAL INSTALLATION

## QUALIFIED INSTALLERS ONLY

### Orifice and Pressure Information.

#### E25 With Log Set & Proflame Valve

Main Burner	Natural Gas	Propane Gas
Orifice:	#38 DMS	#52 DMS
Max. Manifold Press:	3.6 W.C. (0.89 KPa)	10.0" W.C. (2.49 KPa)
Min. Manifold Press:	1.6 W.C. (0.40 KPa)	6.4" W.C. (1.59 KPa)
Max. Supply Press:	7.0" W.C. (1.74 KPa)	11.0" W.C. (2.74 KPa)
Min. Supply Press:	4.5" W.C. (1.12 KPa)	10.4" W.C. (2.59 KPa)
Max. Input:	28,000 BTU/hr (8.2 KW)	28,000 BTU/hr (8.2 KW)
Min. Input:	18,500 BTU/hr (5.42 KW)	22,500 BTU/hr (6.59 KW)

## NEVER USE AN OPEN FLAME FOR LEAK TESTING.

### ADJUSTING THE PILOT FLAME:

The pilot flow adjustment is set to maximum at the factory and should not need to be adjusted. The pilot flame should envelope  $\frac{3}{8}$ " to  $\frac{1}{2}$ " (10 to 13mm) of the Flame sensor (see Figure 35). However, should the need arise, follow Steps 1- 2 below.

1. The adjustment screw can be reached through the front of the unit using a 10 inch long blade head screw driver (see Figure 34 for location on valve).
2. Turn the adjustment screw clockwise to decrease or counterclockwise to increase pilot flame.

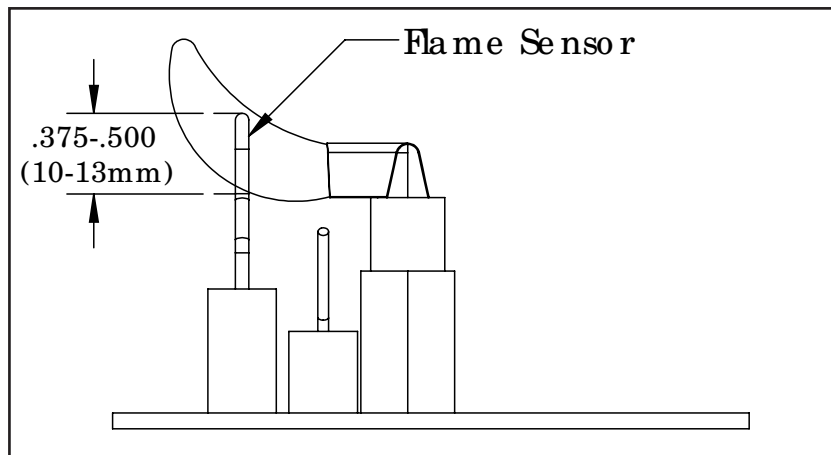

# INITIAL INSTALLATION

## Log Setup Guide

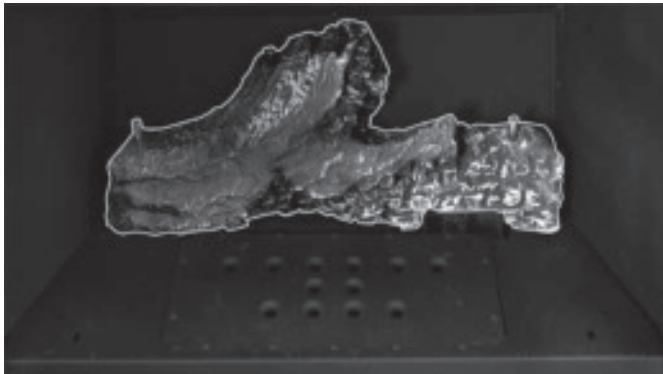
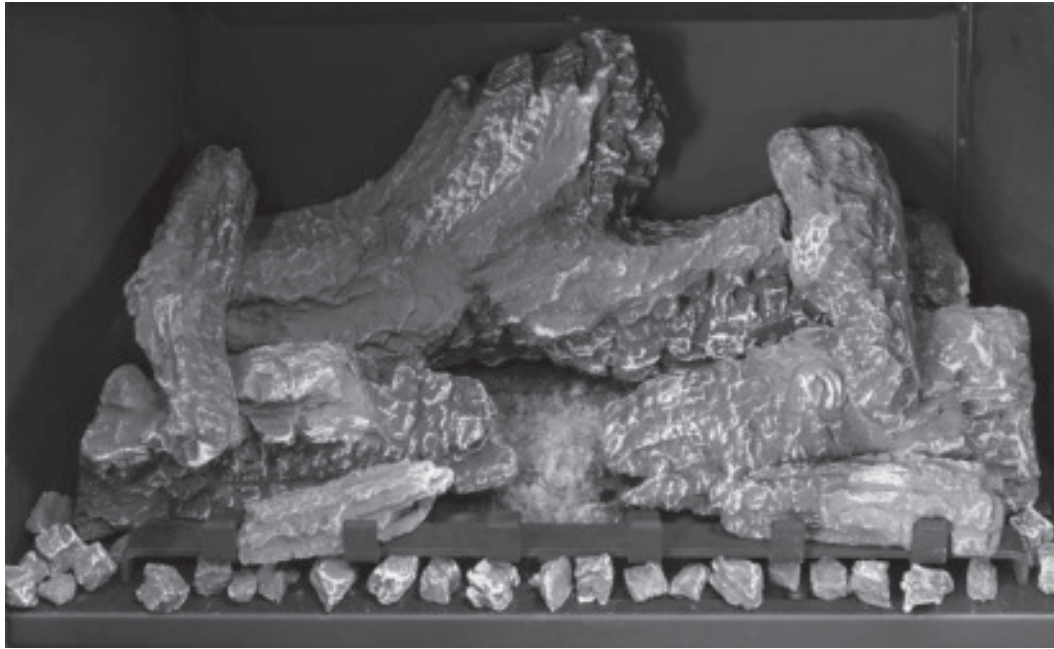

**1.** Place back log at back of firebox, over top of pilot hood.

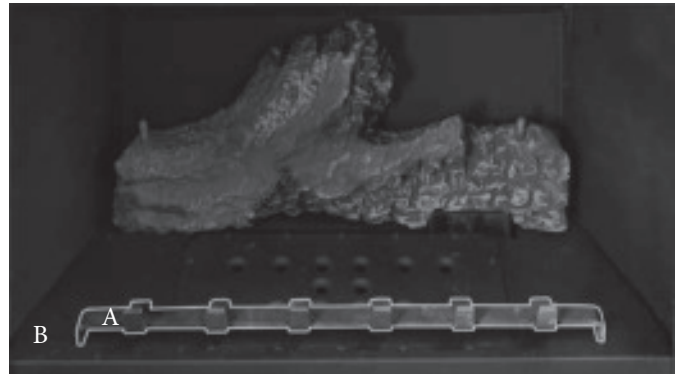

**2.** Rotate the log grate (A) into slots on log deflector (B).

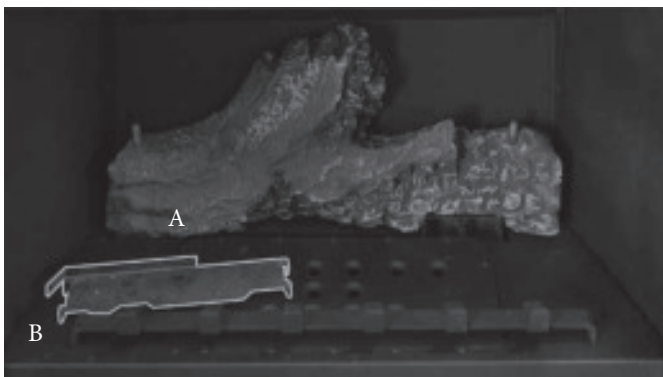

**3.** Locate notches on log stand (A) into holes on log deflector. (B)

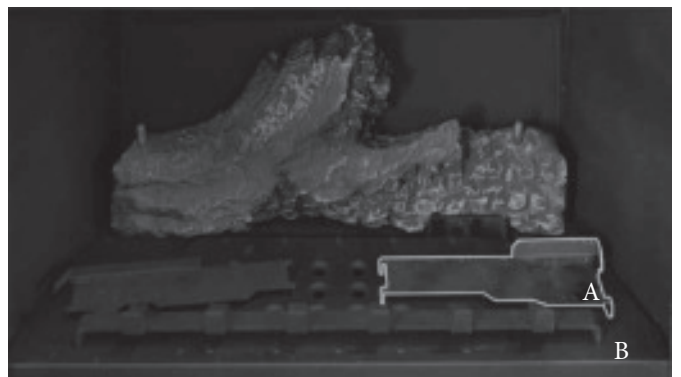

**4.** Locate notches on log stand (A) into holes on log deflector. (B)

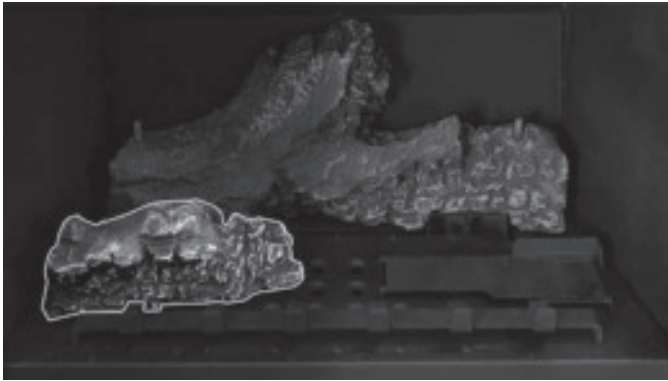

**5.** Place log on log stand. The back left corner of the log locates into the corner of the log stand

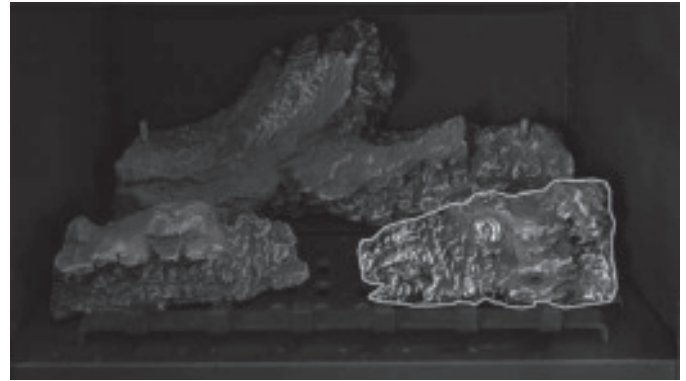

**6.** Place log on log stand. The back right corner of the log locates into the corner of the log stand

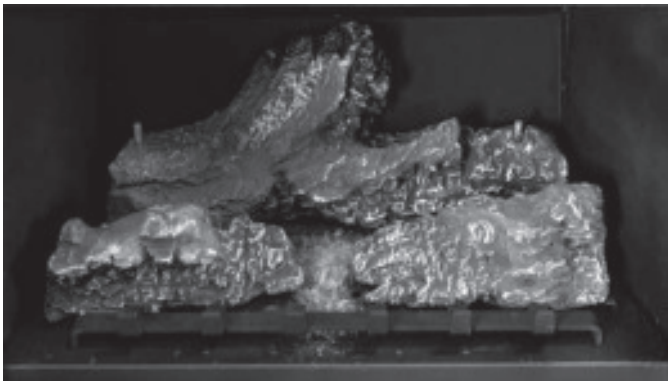

**7.** Using the brush supplied, lightly brush the ember wool onto the Centre of the burner & in between the logs on the left and right. try not to have heavy clumps of wool.

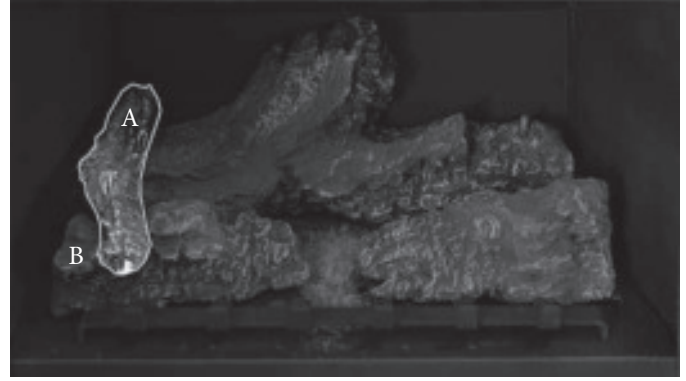

**8.** Insert the (A) log onto the back pin aligning the front of the log to the flat part of the front log. (B

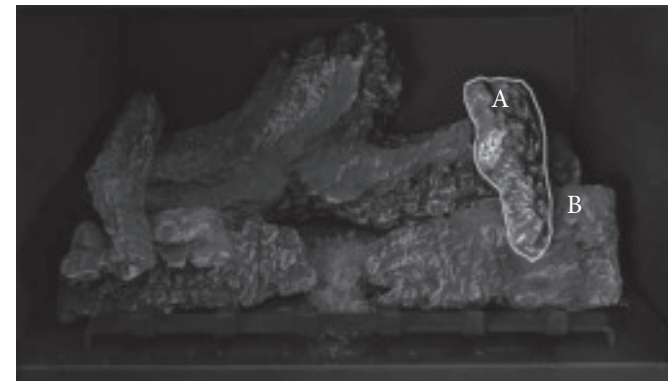

**9.** Insert the (A) log onto the back pin aligning the front of the log to the flat part of the front log (B)

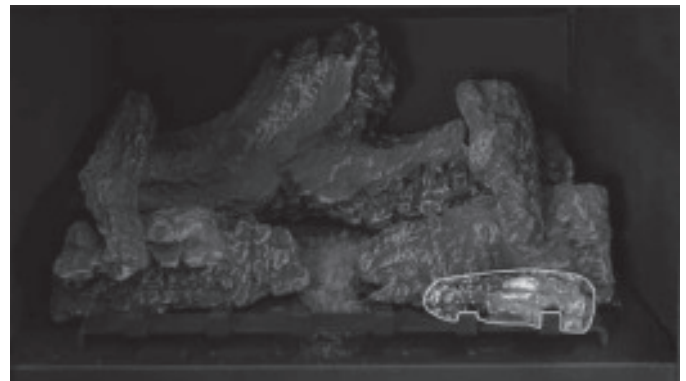

**10.** Locate the notch on the small log and line the Notch up with the end tooth of the log grate.

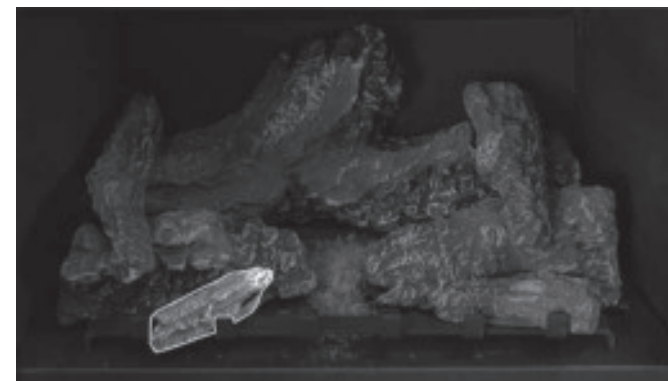

**11.** Locate the end of the log on the last tooth on the left of the log grate.

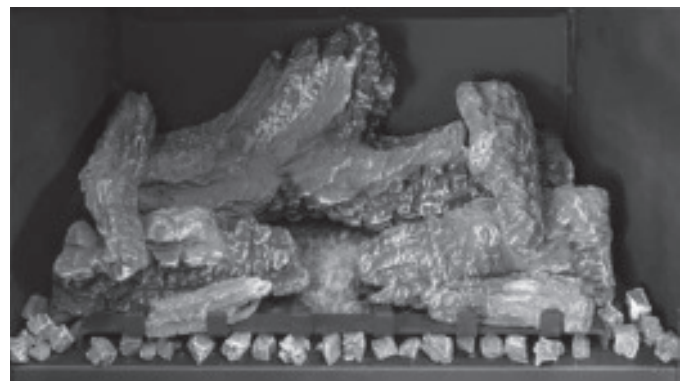

**12.** Add 1 row of coals underneath log grate, use remaining coals to fill in the space at either end of the log grate.

## SECONDARY INSTALLATION

---



8. Re-install the firebox door, then the safety screen.
9. Run the unit for 15 minutes then adjust the venturi as needed using the door tool. above depicts what the burn and flame appearance should look like when the log set is properly installed and venturi adjusted.

When re-lighting the fireplace for the first time since the log set has been installed/replaced, watch for ignition at ALL the burner ports. If a long delay is noticed, turn the appliance off and wait for it to cool down. Then remove the glass and make sure none of the burner ports are blocked.

**Maintenance:** Once a year, the logs should be removed and checked for deterioration or large amounts of soot. A small amount on the bottom side of the logs is normal. Remove and replace the logs in the same manner described above.

If new logs are required, contact your nearest ENVIRO dealer.

**Never operate the fireplace with the glass door removed.**

# TROUBLESHOOTING

---

## DIAGNOSTIC FLASH CODES:

---

1. Fail to ignite: If there is no positive ignition, the board will go into lock out and the LED will blink 3 times in intervals until the system is reset.
2. Low battery condition (<4V): the LED indicator will blink one (1) time in intervals.
3. Parasitic Pilot Flame: the LED indicator will blink two (2) times in intervals.
4. System Lock out: the LED indicator will blink three (3) times in intervals.

### Additional Ignition Information

1. The Proflame2 IFC will try two (2) times for ignition.
2. Each try for ignition will last approximately 60 seconds.
3. The wait time between the two tries is approximately 35 seconds.

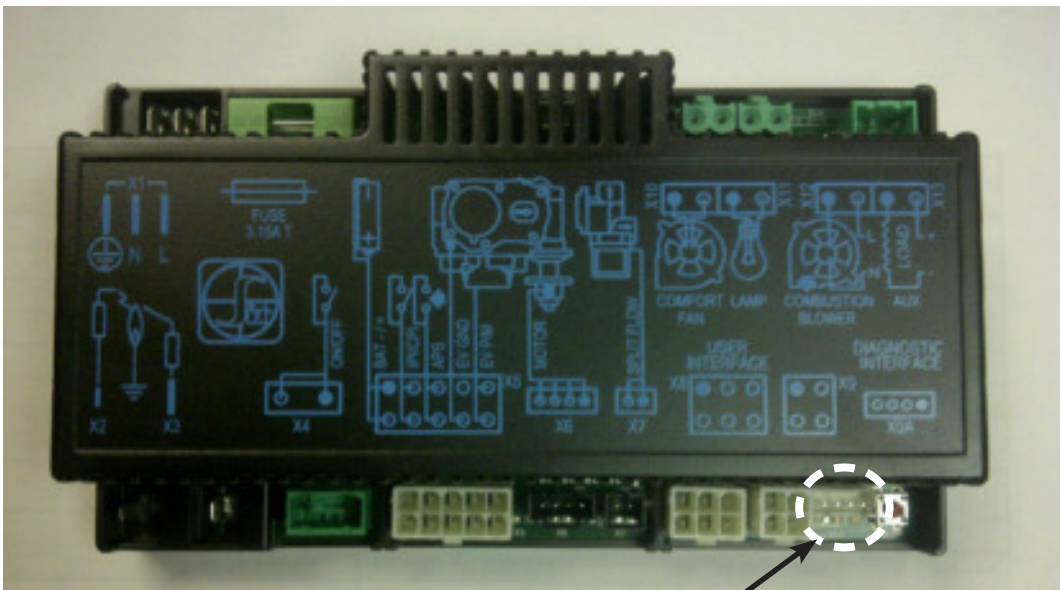

**LED Location**

# TROUBLESHOOTING

Problem	Possible Cause	Solution
Thermostat does not work	The pilot flame has gone out	· Turn it ON
	The On/Off switch is turn to OFF	
	The thermostat is set too high	· Set the thermostat to a lower temperature
No spark generation	Spark develops near the pilot assembly or could occur onboard	· Check pilot assembly wiring
		· Check for broken or poor connection from the sparker to the electrode
		· Check for the spark shorting or arcing at other locations
		· Check for defective sparker and spark electrode
No pilot flame ignition	No spark from the igniter	· See "no spark generation"
	Air in the gas line	· It takes a while for all the air to purge out of the pilot before gas can reach the pilot and ignite
	Pilot gas pressure dropout upon main burner gas valve opening	· Check gas mains supply and pressure
	No gas flow out of the pilot burner	· Check gas valve wirings and connections to the board
		· Check the pilot burner for obstruction
		· Check the wirings and connections between the pilot assembly and the board
· Check the correct gas type settings on the valve and pilot burner assembly orifice		
Pilot will not remain lit	Problem with Flame Sensor circuit	· Check for proper connection of the Flame Sensor to the IFC board
		· Check pilot for full flame impingement around Flame Sensor
		· If flame is too small, check gas pressure, adjust pilot rate screw, check pilot head for damage
		· Ensure the ground wire is properly attached to the pilot mounting bracket and that it is makes a good electrical connection.
	Restrictor setting	· Use the correct restrictor setting for the venting configuration
Remote control (transmitter) does not work	The pilot light has gone out	· See "Pilot will not remain lit"
	The transmitter is too far away from the heater	· Use the transmitter to the heater
	The transmitter batteries are dead	· Replace the batteries
No reaction to command	Transmitter batteries are low	· Replace the batteries
	A maximum number of failed ignitions or flame restorations have been reached.	· Remove any possible blocking conditions. See "locking conditions"
		· See how to reset the board from Lockout
No communication between the remote control and the receiver	No communication between the remote control and the receiver	· Reprogram the transmitter to the receiver.
		· Follow the initializing system for the first time

# TROUBLESHOOTING

Problem	Possible Cause	Solution
Locking conditions	Reset the Proflame IFC board	· Turn the system off by pressing the ON/OFF button on the transmitter
		· After approximately 2 seconds press the ON/OFF button on the transmitter again.
		· In the manual flame control mode, use the down arrow button to reduce the flame to off, indicated by the word OFF displayed on the transmitter LCD screen.
		· Wait approximately 2 seconds and press the up arrow button, the ignition sequence will start.
		· With the transmitter off, disconnect main power from stove for a few seconds then re-connect power.
		· Wait approximately 2 seconds and press the Reset button on the IFC
Main burners will not start	The pilot flame has gone out	· See "Pilot will not remain lit"
	The remote control is not working correctly	· Replace the batteries
	The thermostat is set too high	· Set the thermostat to a lower temperature
Flame lifting	Leak in vent pipe	· Check for leaks in vent connections
	Improper vent configuration	· Check vent configuration with manual
	Terminal may be re-circulating flue gases	· Check to see if terminal is on correctly
		· May need to install high wind termination cap.
		· Contact dealer
Blue Flames	The heater has just been started	· Normal during start up: flame will yellow as the fireplace heats up
	Improper air shutter adjustment	· Adjust air shutter – contact your dealer
Glass fogs up	Normal condition: after the appliance warms up the glass will be clear.	**Due to additives in gas, glass may get hazy during operation** Clean as needed.
Flames are burning "dirty" or sooting	The logs or glasses are placed incorrectly	· Check log positioning
		· Check level of glasses layout
	Improper air shutter adjustment	· Increase primary air by opening the air shutter and/or by opening the vent restrictor
		· Check for proper venting and blockage of the vent termination
		· See also "Burners will not remain lit"
	Incorrect rating input	· Check manifold pressure and clock input rating for over-firing

# PARTS DIAGRAM - COMPONENTS

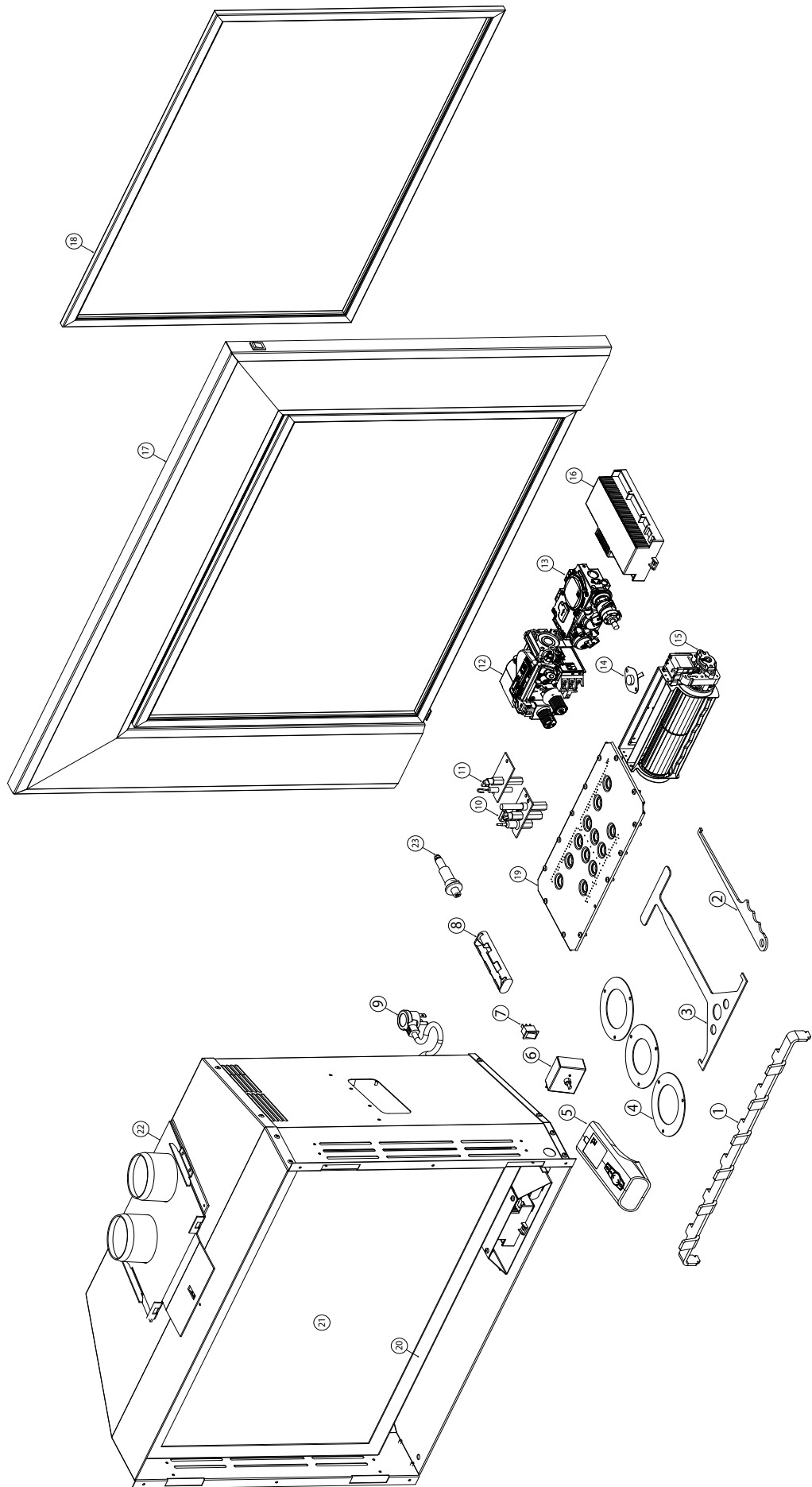

# PARTS LIST

<i>Reference Number</i>	<i>Part Description</i>	<i>Part Number</i>
1	E25 Log Grate	50-3989
2	Door Release Tool	50-2510
3	Flue Adapter Tool	50-3505
4	E25 Exhaust Restrictors	50-3990
5	Proflame 2 Transmitter (0.584.045)	50-3028
6	Fan Controller	EF-045
7	FPI Burner Switch	EC-026
8	Battery Holder 4 x AA	50-3027
9	E25 Power Cord (115V)	EC-042
10	PSE Pilot Assembly (PSE-C4-515) (NOVA)	50-3668
11	PSE IPI Pilot Assembly	50-3026
12	S.I.T. Nova Valve Convertible	50-3660
13	885 Proflame IPI Valve NG	50-2682
14	120 Ceramic Fan Temp Sensor (All Models)	EC-001
15	E25 Fan Only	50-3901
16	Proflame 2 IFC (0.584.325)	50-3312
17	E25 Surround Assembly	50-3845
18	E25 Safety screen only	50-3956
19	E25 Burner Assembly	50-3983
20	E25 complete door Assembly	50-3984
21	E25 Glass & Gasket Only	50-2506
22	E25 Flue adapter	50-3987
23	S.I.T. Piezo Ignitor	EC-023
-	E25 Brick liner	50-3844
-	E25 Valve Tray Gasket	50-3985
-	E25 Flue Adpaptor Gasket	50-3986
-	E25 Flue Adaptor	50-3987
-	E25 Log Set	50-3989
-	Proflame 2 IFC Wire Harnes (0.584.924)	50-3030
-	E25 Conversion Kit NG to LP	50-3981
-	E25 Conversion Kit LP to NG	50-3982
-	Ceramic Wool Embers Only	50-893
-	12 oz. Can of Metallic Black Touch Up Paint	PAINT-12-MB



# Warranty for Enviro Gas Products

Sherwood Industries Ltd. ("Sherwood") hereby warrants, subject to the terms and conditions herein set forth, this product against defects in material and workmanship during the specified warranty period starting from the date of original purchase at retail. In the event of a defect of material or workmanship during the specified warranty period, Sherwood reserves the right to make repairs or to assess the replacement of a defective product at Sherwood's factory. The shipping costs are to be paid by the consumer. All warranties by Sherwood are set forth herein and no claim shall be made against Sherwood on any oral warranty or representation.

## Conditions

- A completed warranty registration must be submitted to Sherwood within 90 days of original purchase via the online warranty registration page or via the mail-in warranty registration card provided. Have the installer fill in the installation data sheet in the back of the manual for warranty and future reference.
- This warranty applies only to the original owner in the original location from date of install.
- The unit must have been properly installed by a qualified technician or installer, and must meet all local and national building code requirements.
- The warranty does not cover removal and re-installation costs.
- Sherwood Industries Ltd. reserves the right to make changes without notice.
- Sherwood Industries Ltd. and its employees or representatives will not assume any damages, either directly or indirectly caused by improper usage, operation, installation, servicing or maintenance of this appliance.
- A proof of original purchase must be provided by you or the dealer including serial number.
- This warranty does not cover any discoloration of the safety screen mesh.

## Exclusions

An expanded list of exclusions is available at [www.enviro.com/help/warranty.html](http://www.enviro.com/help/warranty.html)

This warranty does not cover:

- Damage as a result of improper usage or abuse.
- Damage caused from over-firing due to incorrect setup or tampering.
- Damage caused by incorrect installation.

## To the Dealer

- Provide name, address and telephone number of purchaser and date of purchase.
- Provide date of purchase. Name of installer and dealer. Serial number of the appliance. Nature of complaint, defects or malfunction, description and part # of any parts replaced.
- Pictures or return of damaged or defective product may be required.

## To the Distributor

- Sign and verify that work and information are correct.

### Sherwood Industries Ltd.

6782 Oldfield Road, Victoria, BC . Canada V8M 2A3  
 Online warranty registration: [www.enviro.com/warranty/](http://www.enviro.com/warranty/)

Category	One Year	Two Year	Limited Lifetime (7yr)
Parts <sup>1,2</sup> (unit serial number required)		✓	
Firebox Liner Panels <sup>3</sup>		✓	
Firebox			✓
Heat Exchanger			✓
Burner			✓
Ceramic Logs <sup>4</sup>			✓
Ceramic Glass <sup>5</sup>	✓		
Pedestal / Legs (excluding finish)			✓
Door Assembly			✓
Surround Panels (excluding finish)			✓
Exterior Panels (excluding finish)			Up to 5 years
Electrical Components		✓	
Exterior Surface Finishing	✓		
Labour	✓		

<sup>1</sup> Whereas warranty has expired, replacement parts will be warrantied for 90 days from part purchase date. Labour not included. Unit serial number required.

<sup>2</sup> 50-173 Westport Fan Kit covered for up to 5 years from purchase date. Labour not included. Unit serial required.

<sup>3</sup> Excluding damage to the finish caused by improper setup of the appliance, or color changes.

<sup>4</sup> Log set and panels excludes wear and tear or breakage caused by cleaning or service.

<sup>4</sup> Glass is covered for thermal breakage. Photos of box, inside of door, and unit serial # must be supplied for breakage due to shipping.

<sup>6</sup> Exterior Surface finishing covers plating, enamel or paint and excludes colour changes, chipping, and fingerprints. Travel costs not included.

# INSTALLATION DATA SHEET

The following information must be recorded by the installer for warranty purposes and future reference.

NAME OF OWNER:  
\_\_\_\_\_  
  
ADDRESS:  
\_\_\_\_\_  
\_\_\_\_\_  
\_\_\_\_\_  
  
PHONE: \_\_\_\_\_

NAME OF DEALER:  
\_\_\_\_\_  
  
ADDRESS:  
\_\_\_\_\_  
\_\_\_\_\_  
\_\_\_\_\_  
  
PHONE: \_\_\_\_\_

MODEL: \_\_\_\_\_  
SERIAL NUMBER: \_\_\_\_\_  
DATE OF PURCHASE: \_\_\_\_\_ (dd/mm/yyyy)  
DATE OF INSTALLATION: \_\_\_\_\_ (dd/mm/yyyy)  
 DIRECT VENT  
 NATURAL GAS (NAT)       PROPANE(LPG)  
INLET GAS PRESSURE: \_\_\_\_\_ in WC  
MAIN BURNER ORIFICE: \_\_\_\_\_ # DMS  
PILOT ORIFICE # \_\_\_\_\_ OR \_\_\_\_\_ in diam.  
INSTALLER'S SIGNATURE:  
\_\_\_\_\_

NAME OF INSTALLER:  
\_\_\_\_\_  
  
ADDRESS:  
\_\_\_\_\_  
\_\_\_\_\_  
\_\_\_\_\_  
  
PHONE: \_\_\_\_\_

MANUFACTURED BY:  
SHERWOOD INDUSTRIES LTD.  
6782 OLDFIELD RD. SAANICHTON, BC, CANADA V8M 2A3  
www.enviro.com  
August 2020  
C-15958