



# RZ41

DIRECT VENT FIREPLACE - IPI

# OWNER'S MANUAL

WARRANTY REGISTRATION  
[enviro.com/warranty](http://enviro.com/warranty)



Intertek

C# 4001609

**WARNING:** If the information in this manual is not followed exactly, a fire or explosion may result causing property damage, personal injury or loss of life. Installation and service must be performed by a qualified installer, service agency or the gas supplier.

CERTIFIED TO: ANSI Z21.88 / CSA 2.33 VENTED GAS FIREPLACE HEATERS

CSA 2.17 GAS FIRED APPLIANCES FOR HIGH ALTITUDES

Fr Version Française: [www.enviro.com/fr.html](http://www.enviro.com/fr.html)

50-4641

# SAFETY PRECAUTIONS

---



## **WARNING:**

### **FIRE OR EXPLOSION HAZARD**

**Failure to follow safety warnings exactly could result in serious injury, death, or property damage.**

- **Do not store or use gasoline or other flammable vapours and liquids in the vicinity of this or any other appliance.**
  
- **WHAT TO DO IF YOU SMELL GAS**
  - **Do not try to light any appliance.**
  - **Do not touch any electrical switch; do not use any phone in your building.**
  - **Leave the building immediately.**
  - **Immediately call your gas supplier from a neighbor's phone. Follow the gas supplier's instructions.**
  - **If you cannot reach your gas supplier, call the fire department.**
  
- **Installation and service must be performed by a qualified installer, service agency or the gas supplier.**

### **INSTALLER:**

Leave this manual with the appliance.

### **CONSUMER:**

Retain this manual for future reference.

This appliance may be installed in an after-market permanently located, manufactured (mobile) home, where not prohibited by local codes.

This appliance is only for use with the type of gas indicated on the rating plate. This appliance is not convertible for use with other gases, unless a certified kit is used.

Only doors certified with the appliance shall be used

Massachusetts installations (Warning): This product must be installed by a licensed plumber or gas fitter when installed within the Commonwealth of Massachusetts. Other Massachusetts code requirements: Flexible connector must not be longer than 36in., a shut off valve must be installed; only direct vent sealed combustion products are approved for bedrooms/bathrooms. A carbon monoxide detector is required in all rooms containing gas fired direct vent appliances. The fireplace damper must be removed or welded in the open position prior to installation of a fireplace insert.

# SAFETY PRECAUTIONS

## FOR SAFE INSTALLATION AND OPERATION OF YOUR “ENVIRO” HEATER, PLEASE CAREFULLY READ THE FOLLOWING INFORMATION:

- All ENVIRO gas-fired appliances must be installed in accordance with their instructions. Carefully read all the instructions in this manual first. Consult the building authority having jurisdiction to determine the need for a permit prior to commencing the installation.
- **NOTE:** Failure to follow these instructions could cause a malfunction of the fireplace, which could result in death, serious bodily injury, and/or property damage.
- Failure to follow these instructions may also void your fire insurance and/or warranty.

### GENERAL

• Installation and repair should be done by a qualified service person. The appliance should be inspected before the first use and, at least, annually by a qualified service person. More frequent cleaning may be required due to excessive lint from carpeting, bedding material, etc. It is imperative the control compartments, burners and circulating air passageways of the appliance be kept clean.

• Due to high temperatures, the appliance should be located out of high traffic areas and away from furniture and draperies.

**Children and adults should be alerted to the hazards of high surface temperatures and should stay away to avoid burn or clothing ignition.**

• Young children should be carefully supervised when in the same room as the appliance. Toddlers, young children and others may be susceptible to accidental contact burns. A physical barrier is required if there is a risk for individuals in the house. To restrict access to a fireplace or stove install an adjustable safety gate to keep toddlers, young children and other at risk individuals out of the room and away from hot surfaces. Any safety screen, guard, or barrier removed for servicing an appliance must be replaced prior to operating the appliance.

• Clothing or other flammable materials should not be placed on or near the appliance.

• A barrier designed to reduce the risk of burns from the hot viewing glass is provided with this appliance and shall be installed for the protection of children and other at-risk individuals. If the barrier becomes damaged, the barrier shall be replaced with the manufacturer’s barrier for this appliance.

### FOR YOUR SAFETY

- Installation and service must be performed by a qualified installer, service agency or gas supplier.
- This installation must conform to local codes or, in the absence of local codes, with the National Fuel Gas Code, ANSI Z223.1/NFPA 54, or the Natural Gas and Propane Installation Code, CSA B149.1.
- To prevent injury, do not allow anyone who is unfamiliar with the stove to operate it.

**• To prevent injury, if the pilot or pilot and burners have gone out on their own, open the glass door and wait 5 minutes to air out before attempting to relight the stove.**

• Always keep the area around these appliances clear of combustible material, gasoline and other flammable liquids and vapours.

• These appliances should not be used as a drying rack for clothing or for hanging Christmas stockings/decorations.

• Due to the paint curing on the stove, a faint odor and slight smoking will likely be noticed when the stove is first used. Open a window until the smoking stops.

Always connect this gas stove to a vent system and vent to the outside of the building envelope. Never vent to another room or inside the building. Make sure the specified vent pipe is used, properly sized and of adequate height to provide sufficient draft. Inspect the venting system annually for blockage and signs of deterioration.

**WARNING:** Failure to position the parts in accordance with the diagrams in this booklet, or failure to use only parts specifically approved with this appliance, may result in property damage or personal injury.

**WARNING:** Do not operate with the glass front removed, cracked or broken. Replacement of the glass should be done by a licensed or qualified service person.

• Never use solid fuels such as wood, paper, cardboard, coal, or any flammable liquids, etc., in this appliance.

• Do not use this appliance if any part has been under water. Immediately call a qualified service technician to inspect the appliance and to replace any part of the control system or any gas control which has been under water.

• Do not abuse the glass by striking it or slamming the door shut.

• If the RZ41 unit is pulled out of its installation, and the vent-air intake system is disconnected for any reason, ensure that the vent-air intake pipes are reconnected and re-sealed in accordance to the instructions noted in INITIAL INSTALLATION - DIRECT VENT

 **DANGER**



**HOT GLASS WILL CAUSE BURNS**  
**DO NOT TOUCH GLASS UNTIL COOLED.**  
**NEVER ALLOW CHILDREN TO TOUCH GLASS.**

A barrier designed to reduce the risk of burns from the hot viewing glass is provided with this appliance and must be installed for the protection of children and other at-risk individuals.

# TABLE OF CONTENTS

---

<b>Safety Precautions</b> .....	<b>2</b>
<b>Table of Contents</b> .....	<b>4</b>
<b>Codes &amp; Approvals</b> .....	<b>6</b>
<b>Specifications</b> .....	<b>7</b>
RZ41 Dimensions: .....	7
Rating Label & Lighting Instructions Location: .....	7
<b>Safety and Lighting Instructions</b> .....	<b>8</b>
<b>Operating Instructions</b> .....	<b>9</b>
Normal Sounds During Operation:.....	9
System Description: .....	9
Technical Data.....	9
Remote Control: .....	9
Integrated Fireplace Controller (IFC):.....	10
Operating Procedure: .....	11
Battery Backup:.....	13
<b>Annual Maintenance</b> .....	<b>14</b>
Cleaning The Glass: .....	14
Cleaning The Firebox: .....	14
Replacing the Glass: .....	14
Cleaning Decorative Surfaces: .....	14
Surround Removal: .....	15
Glass Door Removal: .....	15
<b>Maintenance And Service</b> .....	<b>16</b>
Pilot Light: .....	16
Burner & Log Grate Removal: .....	16
Air Shutters:.....	17
Ember Lights - Bulb Replacement: .....	18
<b>Fuel Conversion</b> .....	<b>19</b>
<b>Initial Installation</b> .....	<b>21</b>
Introduction: .....	21
Unit Install Preparation: .....	21
Placement and Framing: .....	24
Clearances & Non-Combustible: .....	25
Flooring: .....	26
Mantel Clearances: .....	26
Cool Surface Activation: .....	27
Finishing the Fireplace .....	27
Cool Surface Install Options: .....	29
Required Vent Heat Shields: .....	32
Minimum Installation: .....	33
Recess Installation:.....	34
Corner Installation:.....	35
TV Installation:.....	36

# TABLE OF CONTENTS

---

Direct Vent:.....	38
Thimble & General Venting Clearances: .....	38
Vent Termination Restrictions: .....	39
Approved Venting Parts:.....	40
Permitted Venting Configurations: .....	41
Power Vent Baffle (50-4642).....	44
Exhaust Restrictor Setting: .....	44
Horizontal Termination: .....	45
Vertical Termination: .....	46
Gas Line Connection and Testing: .....	48
Electrical Requirements:.....	49
<b>Secondary Installation .....</b>	<b>50</b>
Firebox Liner Removal / Installation: .....	50
Burner Nickel Stranding: .....	51
Log Set Installation:.....	52
<b>Troubleshooting .....</b>	<b>56</b>
<b>Parts Diagram.....</b>	<b>57</b>
<b>Replacement Parts &amp; Options List.....</b>	<b>58</b>
<b>Warranty .....</b>	<b>59</b>
<b>Installation Data Sheet .....</b>	<b>60</b>

# CODES & APPROVALS

---

**DIRECT VENT ONLY:** This type is identified by the suffix DV. This appliance draws all of its air for combustion from outside the dwelling, through a specially designed vent pipe system.

This appliance has been tested and approved for installations from 0 feet to 4500 feet (1372 m) above sea level.

**In the USA:** The appliance may be installed at higher altitudes. Please refer to your American Gas Association guidelines which state: the sea level rated input of Gas Designed Appliances installed at elevations above 2000 (610 m) feet is to be reduced 4% for each 1000 feet (305 m) above sea level. Refer also to local authorities or codes which have jurisdiction in your area regarding the de-rate guidelines.

**In Canada:** When the appliance is installed at elevations above 4500 feet (1372 m), the certified high altitude rating shall be reduced at the rate of 4% for each additional 1000 feet (305 m).

- This appliance has been tested by INTERTEK and found to comply with the established VENTED GAS FIREPLACE HEATER standards in CANADA and the USA as follows:

## **VENTED GAS FIREPLACE HEATER (RZ41 ; NATURAL GAS, PROPANE GAS)**

TESTED TO: ANSI Z21.88 / CSA 2.33 VENTED GAS FIREPLACE HEATERS

CSA 2.17 GAS FIRED APPLIANCES FOR HIGH ALTITUDES

### **This ENVIRO Fireplace:**

- Has been certified for use with either natural gas or propane (see rating label).
- Is not for use with solid fuels.
- Is approved for a bedroom or bed sitting room.

**IN CANADA:** Using the supplied remote control or other thermostat control.

**IN USA:** see current ANSI Z223.1 for installation instructions.

- Must be installed in accordance with local codes. If none exist, use current installation code CAN/CGA B149.1 in Canada or ANSI Z223.1/NFPA 54 in the USA.
- Must be properly connected to an approved venting system and not connected to a chimney flue serving a separate solid-fuel burning appliance.

**IMPORTANT NOTICE (Regarding first fire up):** When the unit is turned on for the first time, it should be turned onto high without the fan on (if equipped) for the first 4 hours. This will cure the paint, logs, gasket material and other products used in the manufacturing process. It is advisable to open a window or door, as the unit will start to smoke and can irritate some people. After the unit has gone through the first burn, turn the unit off including the pilot, let the unit get cold then remove the glass door and clean it with a good gas fireplace glass cleaner, available at your local ENVIRO dealer.

**NATIONAL  
FIREPLACE  
INSTITUTE®**



**CERTIFIED**

**[www.nficertified.org](http://www.nficertified.org)**

We recommend that our gas hearth products be installed and serviced by professionals who are certified in the U.S. by the National Fireplace Institute® (NFI) as NFI Gas Specialists.

# SPECIFICATIONS

## RZ41 DIMENSIONS:

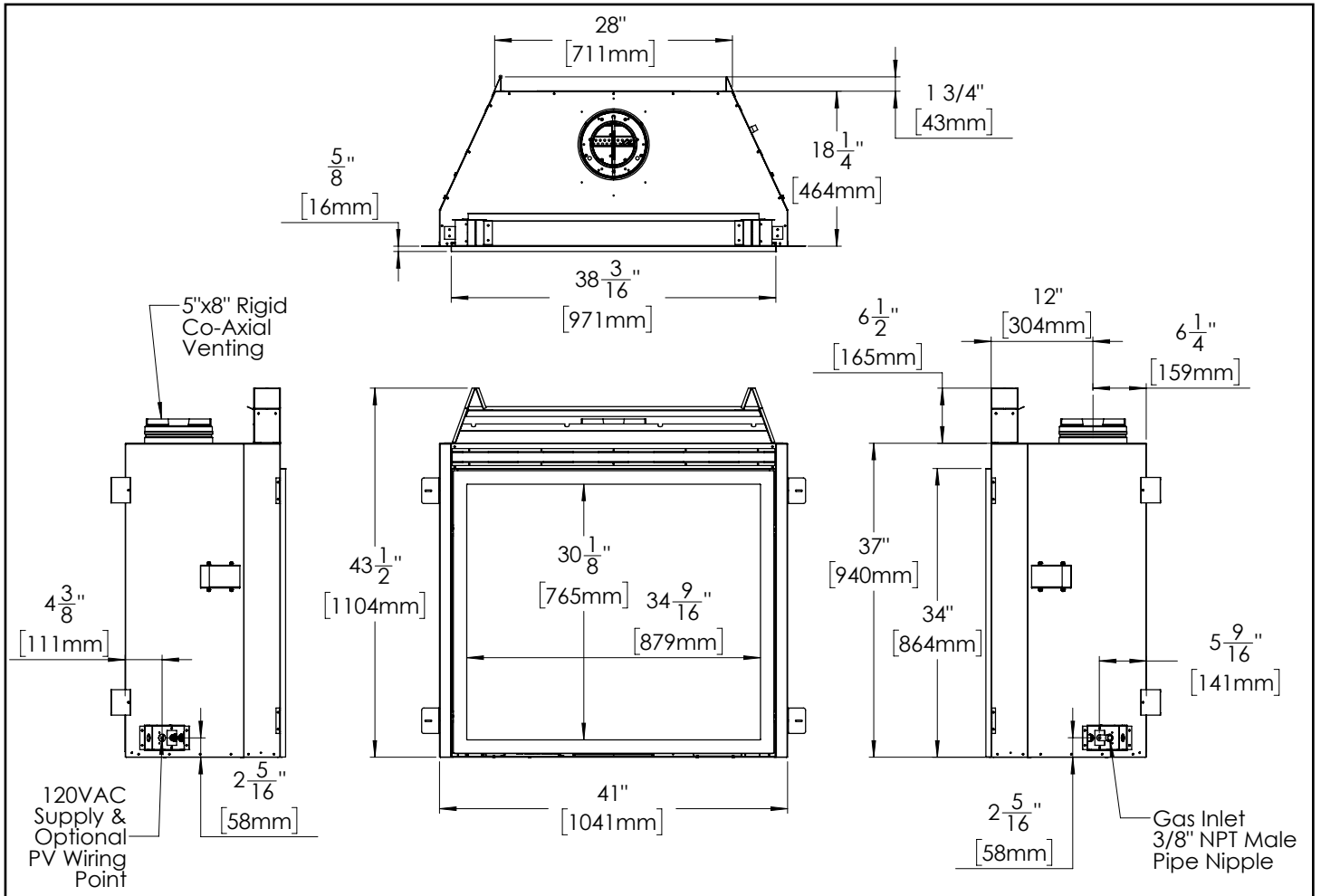


Figure 1: RZ41 Dimensions

## RATING LABEL & LIGHTING INSTRUCTIONS LOCATION:

Remove the surround completely to access the rating label and lighting instructions. The rating label is attached to a length of chain and is never to be tampered with or removed. All important information for your fireplace is on this label as well as the model specific serial number which you will need for warranty information. The sheet is located inside the cabinet under the gas valve.

# **SAFETY AND LIGHTING INSTRUCTIONS**

**For Your Safety, Read Safety Precautions and Lighting Instructions Before Operating**

**WARNING:** IF YOU DO NOT FOLLOW THESE INSTRUCTIONS EXACTLY, A FIRE OR EXPLOSION MAY RESULT CAUSING PROPERTY DAMAGE, PERSONAL INJURY OR LOSS OF LIFE

**A.** This appliance is equipped with an ignition device which automatically lights the pilot. **DO NOT** try to light the pilot by hand.

**B.** BEFORE OPERATING smell all around the appliance area for gas. Be sure to smell next to the floor because some gas is heavier than air and will settle on the floor.

WHAT TO DO IF YOU SMELL GAS:

- DO NOT try to light any appliance
- DO NOT touch any electrical switch; DO NOT use any phone in your building.
- Immediately call your gas supplier from a neighbour's phone. Follow the supplier's instructions.
- If you cannot reach your gas supplier, call the fire department

**C.** Use only the remote supplied with this fireplace. Never use tools, don't try to repair it, call a qualified service technician. Force or attempted repair may result in a fire or explosion.

**D.** Do not use this appliance if any part has been under water. Immediately call a qualified service technician to inspect the appliance and to replace any part of the control system and any gas control which has been under water.

## **LIGHTING INSTRUCTIONS:**

---

1. STOP! Read the safety information above.
2. Read this Owner's Manual including the section on "Remote Control" operation.
3. Turn off all electric power to the appliance.
4. DO NOT attempt to light the pilot by hand.
5. Wait five (5) minutes to clear out any gas. Then smell for gas, including near the floor. If you smell gas, STOP! Follow "B" in the safety information above. If you don't smell gas, go to the next step.
6. Turn on all electric power to the appliance.
7. Using the remote control, press the ON/OFF key on the remote (Figure 2). "ON" will be indicated on the display of the remote and an audible "beep" will be heard at the unit to indicate the command has been received.
8. If the appliance will not operate, follow the instructions "To Turn Off Gas to Appliance" below and call your service technician or gas supplier.

## **To Turn Off Gas to Appliance:**

---

1. Set thermostat to lowest setting, or press the ON/OFF key. "OFF" will be indicated on the display and an audible "beep" will be heard at the unit to indicate the command has been received.
2. Turn off all electric power to the appliance if service is to be performed.

# OPERATING INSTRUCTIONS

## NORMAL SOUNDS DURING OPERATION:

Table 1: Normal Sounds

Component	Normal Sound Description
Main Unit	Creaking when heating up or cooling down
Burner	Light pop or poof when turned on or off
Pilot Flame	Quiet whisper while the pilot flame is on
Blower / Fan	Air movement that increase and decreases with the speed of the blower
Gas Valve	Dull click when turning on or off, this is the valve opening and closing

## SYSTEM DESCRIPTION:

The Proflame 2 Remote Control System consists of two (2) elements:

1. Proflame 2 Transmitter.
2. Integrated Fireplace Controller (IFC) and wiring harness to connect to the gas valve, stepper motor battery holder, convection fan, and lights.

### **ATTENTION!**

- **TURN “OFF” THE MAIN GAS SUPPLY OF THE APPLIANCE DURING INSTALLATION OR MAINTENANCE OF THE IFC.**
- **TURN “OFF” MAIN GAS SUPPLY TO THE APPLIANCE PRIOR TO REMOVING OR REINSERTING THE BATTERIES IN THE BATTERY HOLDER**

## TECHNICAL DATA

### **Transmitter (Remote Control):**

Supply voltage: 4.5 V (three 1.5 V AAA batteries)  
Radio frequency: 315 MHz

### **Integrated Fireplace Controller (IFC):**

Supply voltage: AC IN - 120 V / 60 Hz  
Battery Backup IN - 6 Vdc - 200mA (four 1.5 V AA batteries)  
Spark voltage / frequency: > 10kV / 1Hz  
Comfort modulating fan: 120 V / 60 Hz / 2A  
Auxiliary: 120 V / 60 Hz / 5A

## REMOTE CONTROL:

The Proflame 2 system uses a streamline design remote transmitter to allow the user to interact with the system. The simple button layout and LCD display offer a user friendly experience. The MODE key is used to cycle through different features and the THERMOSTAT key is used to manage thermostatic functions. The transmitter is powered by three (3) AAA type batteries.

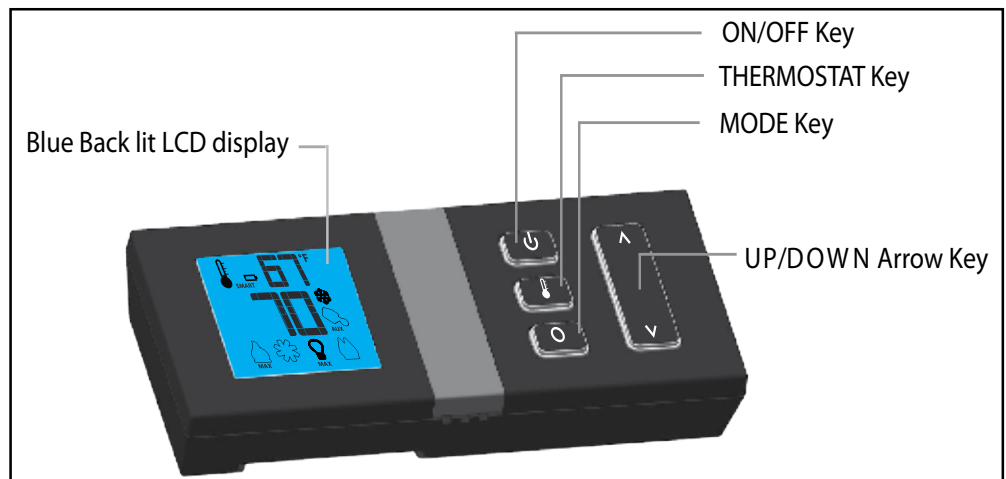


Figure 2: Proflame 2 Transmitter.

# OPERATING INSTRUCTIONS

**WARNING: Fire Hazard.** Can cause severe injury or death. The Transmitter causes ignition of the appliance. The appliance can turn on suddenly. Keep away from the appliance burner when operating the remote system.

**CAUTION: Property Damage Hazard.** Excessive heat can cause property damage. The appliance can stay lit for many hours. Turn off the appliance if it is not going to be attended for any length of time. Always place the Transmitter where children cannot reach it.

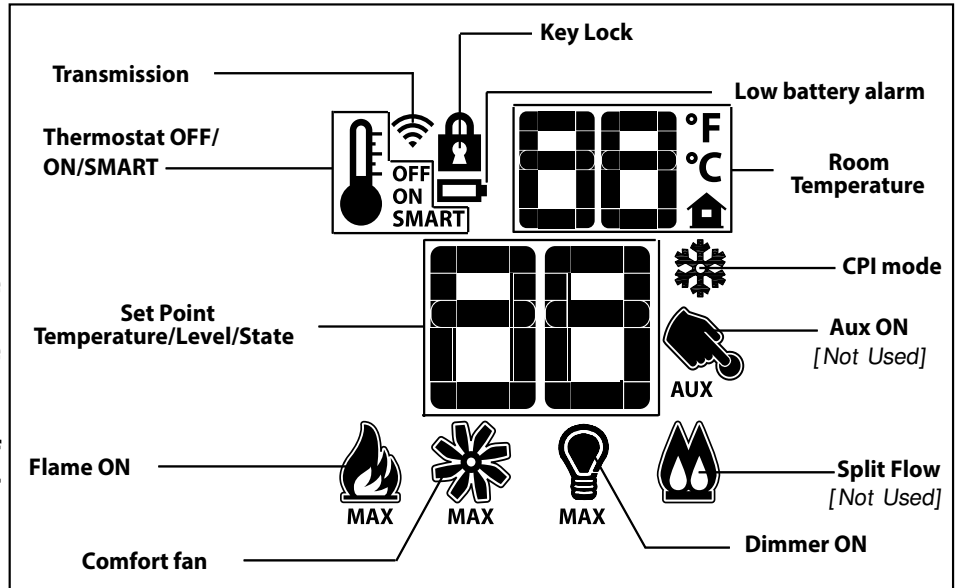
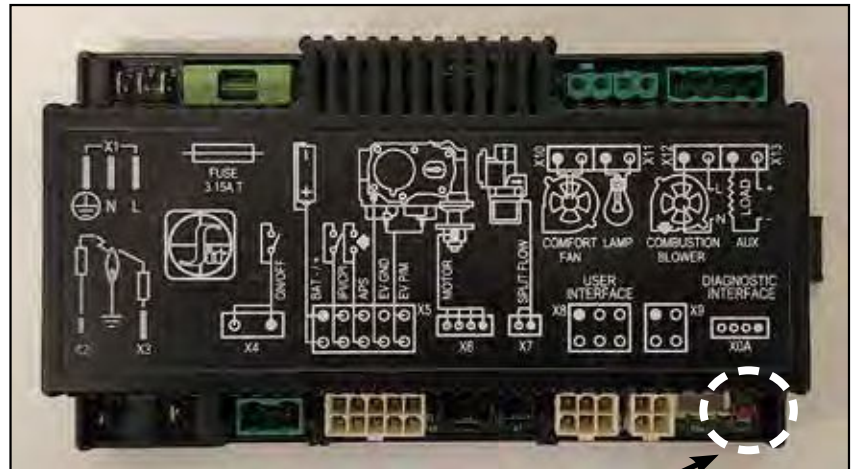


Figure 3: Proflame 2 Transmitter LCD Screen.

## INTEGRATED FIREPLACE CONTROLLER (IFC):

The IFC is the master controller for your fireplace control system known as Proflame 2. This unit will control all aspects of the fireplace by receiving commands from the remote transmitter. This controller is powered by 120VAC but can also run off a (4) AA battery backup if there is a power outage. Only main burner control can be used while operating with the battery back up; auxiliary components, such as the convection fan, cannot be used. Use the reset button (see Figure 4) to synchronize the remote transmitter to the IFC for the first time, or after batteries have been replaced.



Reset Button

Figure 4: Integrated Fireplace Controller

## OPERATING PROCEDURE:

### Initializing The System

Install the four (4) supplied AA batteries into the IFC battery holder (see Battery Backup section). Install the three (3) supplied AAA batteries into the back of the remote transmitter. Press the reset button on the IFC (see Figure 4) and listen for three (3) beeps. Press the ON key on the remote transmitter and listen for another beep sequence. Once the command has been accepted then the system is initialized and ready for use.

**Note: Other remote transmitters may interfere with the system if you have another within the vicinity.**

# OPERATING INSTRUCTIONS

## Temperature Indication Display

Press the Thermostat key and the Mode key simultaneously while the system is OFF. The remote transmitter will indicate which temperature scale is being displayed ( $^{\circ}\text{C}$  or  $^{\circ}\text{F}$ ). Repeat this sequence to change the scale (see Figure 5).



Figure 5: Temperature Scale Display

## Turn on the Appliance

Press the ON/OFF key on the remote transmitter; the display will illuminate and show all active icons. A single beep from the IFC will confirm the command from the remote and the start up sequence will begin. The spark electrode will ignite the pilot flame which will engulf the flame sensor hook. After the sensor reaches sufficient temperature, the main burner valve will open and the flame will ignite moments after.

**Note: If the pilot takes too long to ignite there may be air in the gas line. The system will enter a 5 minute lock-out and cancel the start-up procedure if too many spark attempts have been made. If pilot cannot light after 3 lock-out cycles then contact your gas fitter.**

## Turn off the Appliance

Press the ON/OFF key on the transmitter to turn the fireplace off. The IFC will confirm your command with a single beep. The pilot light (IPI) and the main burner will turn off. The pilot will remain lit if the fireplace is in CPI mode. Room temperature information will still be displayed on the remote when the unit is off.

## Continuous Pilot Mode (CPI)

Press the Mode key with the fireplace turned off. Use the UP/DOWN key to cycle between intermittent pilot ignition (IPI) and continuous pilot ignition (CPI). Press the mode key to make your selection and the IFC will beep to confirm your command. The snowflake icon will now be displayed on the remote control screen whenever the fireplace is off.

**Note: It is recommended to use CPI mode when the temperature outside is below  $50^{\circ}\text{F}$  ( $10^{\circ}\text{C}$ ) to keep the vent sufficiently heated to assist with warm-up procedure. Using CPI will also eliminate excessive condensation on the glass during start-up.**

**Note: This appliance is equipped with an on-demand pilot that, if left dormant, will shut down after 7 consecutive days.**

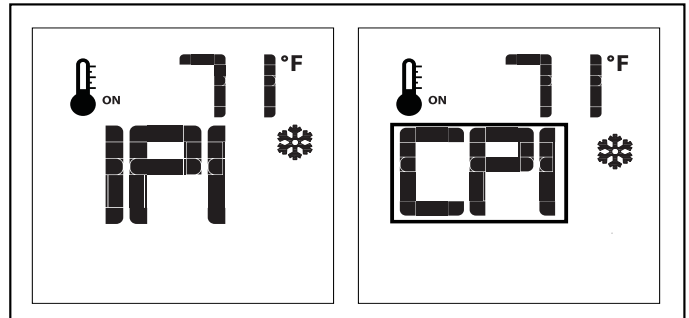


Figure 6: CPI Pilot Mode.

## IPI / CPI Switch

This fireplace has a manual override IPI/CPI switch located behind the surround panel at the front bottom left of the fireplace. The default position of the switch from the factory is IPI. To put the fireplace into CPI mode, toggle the switch to the CPI position. The fireplace will not be capable of CPI mode with the switch in the IPI position. The switch can be left in the CPI position indefinitely and the fireplace can still be adjusted back to IPI via the remote control as described in the section above.

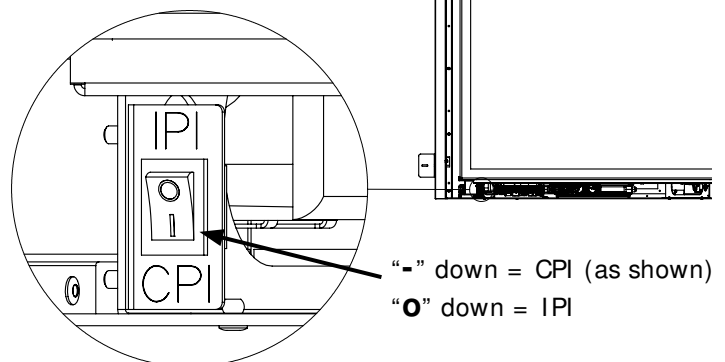


Figure 7: IPI / CPI Switch

# OPERATING INSTRUCTIONS

## Room Thermostat (Transmitter Operation)

The remote transmitter acts as a room thermostat. The thermostat can be set to a desired temperature to control the comfort level in a room. Press the THERMOSTAT key to activate this function. The transmitter display will indicate the thermostat is ON and the set temperature can be adjusted with the UP/DOWN key. The flame will cycle on and off to regulate temperature in this mode.

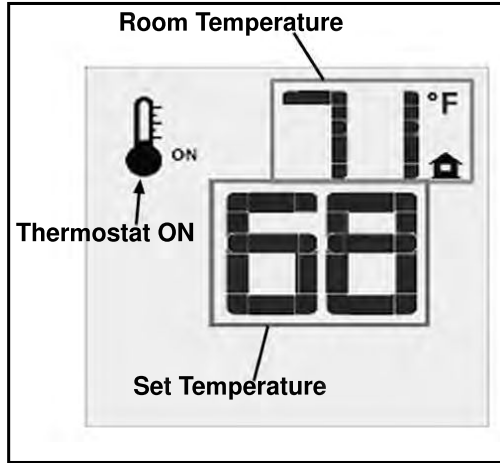


Figure 8: Thermostat Function

## Remote Flame Control

The Proflame 2 remote control system has six (6) flame levels. Adjust the flame level using the UP/DOWN key; each time the button is pressed the IFC will beep to confirm your command. The remote display will show which level the flame is currently at.

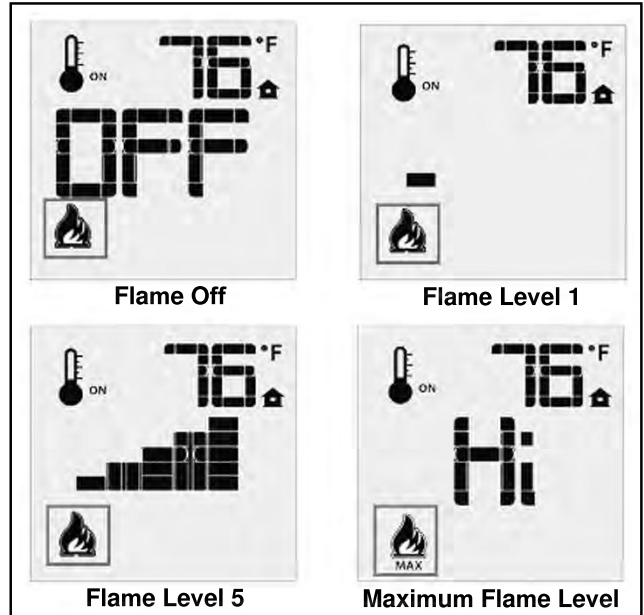


Figure 10: Flame Control

## Smart Thermostat (Transmitter Operation)

The remote acts as a smart thermostat. Press the THERMOSTAT key until SMART is displayed. The smart thermostat function has the ability to modulate the flame level with reference to the set point. The flame will level down when the actual temperature approaches the set temperature.

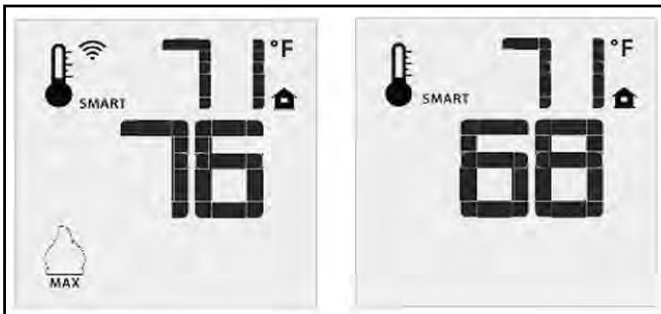


Figure 9: Smart Thermostat Function

## Fan Control

The Proflame 2 remote control system has six (6) fan speed levels. Adjust the fan speed using the UP/DOWN key; each time the button is pressed the IFC will beep to confirm your command. The remote display will show which level the fan speed is currently at.

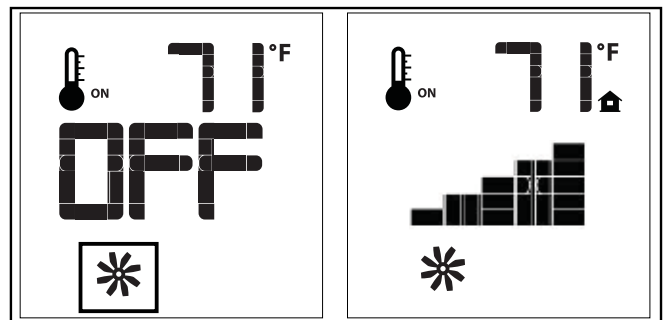


Figure 11: Fan Control

# OPERATING INSTRUCTIONS

## Ember Lights Control

The ember lights are at the front of the fireplace and can be controlled with the transmitter. The Proflame 2 remote control system has six (6) light intensity levels. Adjust the light intensity using the UP/DOWN key; each time the button is pressed the IFC will beep to confirm your command. The remote display will show what level the ember lights are currently at.

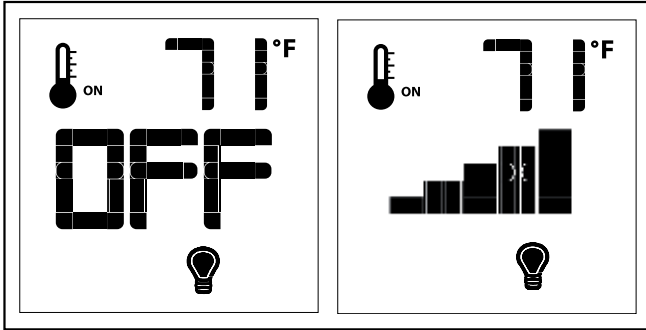


Figure 12: Ember Light Control

## Key lock

This function will lock the keys to avoid unsupervised operation. Press the MODE and UP key simultaneously to activate this function. Repeat this sequence to deactivate. A lock icon will be displaced on the screen when activated.



Figure 13: Key Lock

## Low Battery Power Detection

A low battery icon will be displayed on the remote transmitter when the transmitter batteries are low. It is advisable to change the batteries at this point before all power is lost from the remote.

There is no icon on the remote transmitter indicating low battery power for the IFC. The IFC will emit a beep when the ON/OFF key is pressed indicating the batteries are low.

The system will need to be initialized after battery replacement (see INITIALIZING THE SYSTEM). The life span of the batteries depends on various factors such as battery quality, ignition attempts, remote usage, and power outage duration.

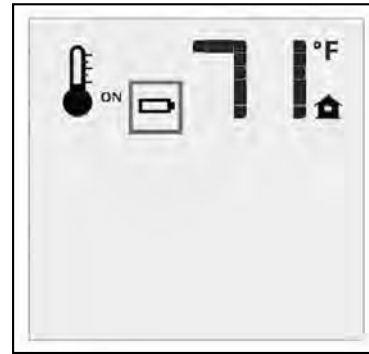


Figure 14: Low Battery

## Battery Backup

In the event of a power outage the fireplace will still be able to operate the main burners via a four AA battery backup. The battery backup is located behind the surround panel at the front bottom left of the fireplace. The plastic battery holder simply slides out from the steel sleeve attached to the fireplace cabinet. The battery holder can be fully removed from the fireplace by disconnecting the low voltage battery snap wires. Batteries should be checked annually to confirm they are still functional. Replace as needed.

Note - Fan control and ember lights will not be operational when the fireplace is operating on battery backup.

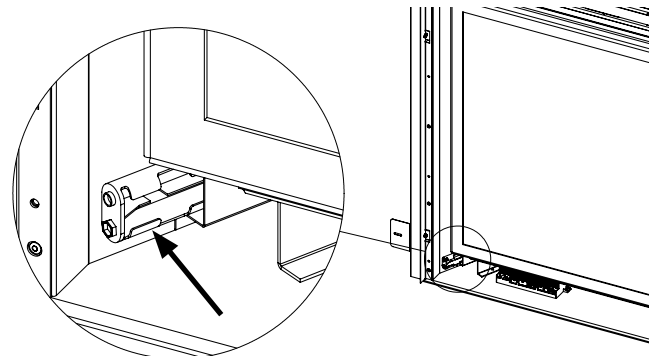


Figure 15: Battery Backup

# ANNUAL MAINTENANCE

---

Run through the following procedures to ensure the system is clean and working properly at least once a year. Check the burner to see if all the ports are clear and clean. Check the pilot to make sure it is not blocked by anything. The pilot flame should be blue with little or no yellow tips.

**WARNING:** Failure to position parts in accordance with this manual, or failure to use only parts specifically approved with this appliance may result in property damage or personal injury.

The venting system must be periodically examined; it is recommended the examination is done by a qualified agency.

## CLEANING THE GLASS:

---

**With the fireplace cooled**, remove the surround panel and glass door (See MAINTENANCE AND SERVICE - SURROUND PANEL REMOVAL and MAINTENANCE AND SERVICE - GLASS DOOR REMOVAL). Check the gasket material on the back of the glass, making sure that it is attached and intact. During a cold start up, condensation will sometimes form on the glass. This is a normal condition with all gas fireplaces. This condensation can allow dust and lint to cling to the glass surface which requires periodic cleaning. Initial paint curing of the appliance can leave a slight film behind the glass, a temporary problem. The glass will need cleaning about two weeks after installation.

**Use a mild glass cleaner and a soft cloth. Abrasive cleaners will damage the glass and painted surfaces.** Depending on the amount of use, the glass should require cleaning no more than two or three times a season.

**WARNING: Do not clean the glass when it is hot.**

## CLEANING THE FIREBOX:

---

Carefully remove the logs, they are fragile. Gently remove all the media and place on a paper towel. Vacuum the bottom of the firebox thoroughly. Carefully clean any dust off the logs and remove any lint from the burner and pilot. At this time, inspect the burner tube for cracking or severe warping. If a problem is suspected, contact the dealer. Check the logs for deterioration or large amounts of soot; a small amount on the bottom side of the logs is normal. Replace the logs as shown in the SECONDARY INSTALLATION - LOG SET INSTALLATION section. If new/more media is required, contact your nearest ENVIRO dealer.

## REPLACING THE GLASS:

---

The glass in the fireplace door is ceramic glass. If the glass is damaged in any way, a factory replacement is required (see PARTS LIST). Wear gloves when handling damaged glass door assembly to prevent personal injury. Do not operate with the glass front removed, cracked or broken. Removal and replacement of the glass from the door **must** be done by a licensed or qualified service person. **The glass must be purchased from an ENVIRO dealer. No substitute materials are allowed.** To remove the door (see MAINTENANCE AND SERVICE - GLASS DOOR REMOVAL). The replacement glass will come with a new gasket installed. Remove any silicone remnants from the door. Apply high temperature silicone around the perimeter of the door and install the new piece of glass with gasket. Apply even pressure to the glass to allow the silicone to adhere to the gasket material.

## CLEANING DECORATIVE SURFACES:

---

Painted and porcelain faces should be wiped with a damp cloth periodically. If a plated face has been purchased, it should be unpacked carefully to avoid getting anything on the surface of the finish, including cleaners, polish and finger prints. It is important to note that fingerprints and other marks can leave a permanent stain on plated finishes. **To avoid this, give the face a quick wipe with denatured alcohol on a soft cloth BEFORE lighting the fireplace.** Never clean the face when it is hot. Do not use other cleaners as they may leave a residue, which can become permanently etched into the surface.

# ANNUAL MAINTENANCE

## SURROUND REMOVAL:

**WARNING: Do not attempt to remove the surround panel until the unit has completely cooled.**

There are four mounting hooks, two per side, that hold the surround on the fireplace (see Figure 16). The hooks have two mount positions to keep the surround flush with either 5/8" or 7/8" thick finishing material. To remove the surround, grab the inside edges of the outer frame, lift up and bring outward. For installation, hold the surround by the inside edges, center it in front of the fireplace and then lift up and forward.

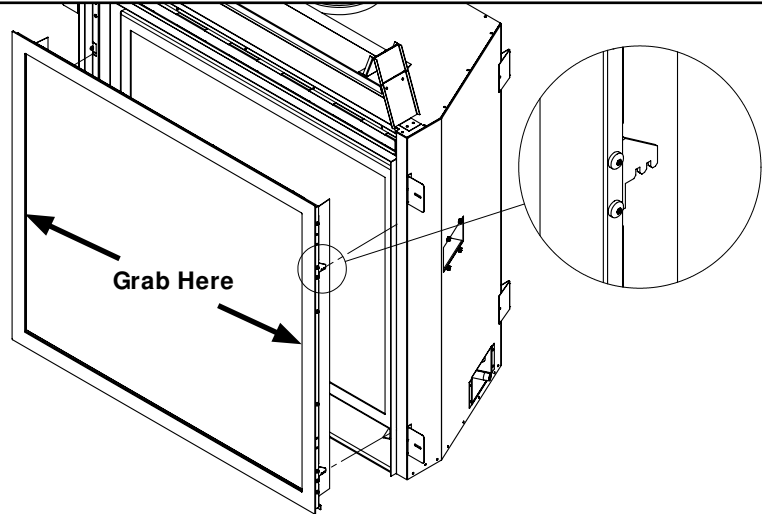


Figure 16: Surround Removal

## GLASS DOOR REMOVAL:

**WARNING: Do not touch or attempt to remove the glass door if the fireplace is not completely cold.**

**WARNING: Never operate the fireplace with the glass door removed.**

No tools are required to remove the fireplace glass door.

1. Release the two top spring latches using your index fingers to pull the latches forward, then up off the door tabs (figure 17).
2. Lay the door forward until it is almost parallel with the floor and remove it from the bottom retainer (figure 18).

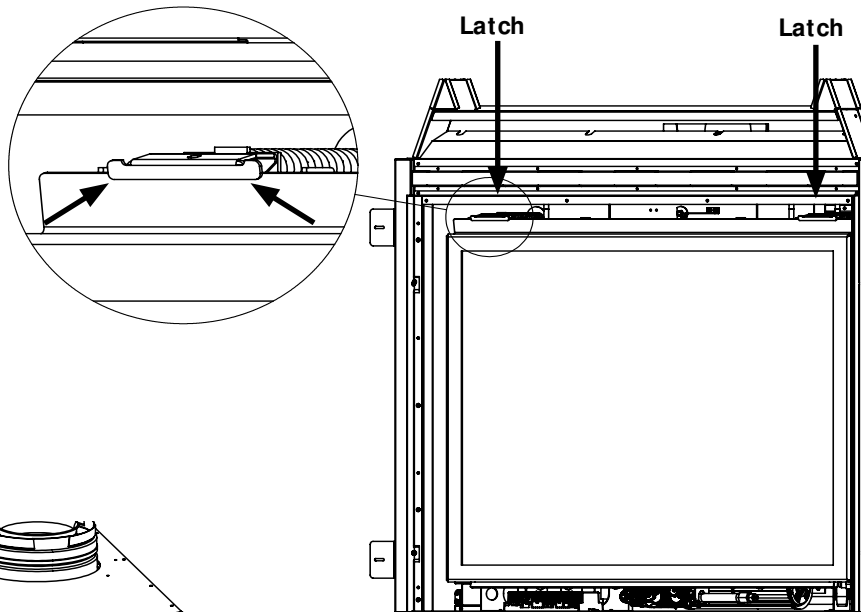


Figure 17: Glass Door - Latch Removal

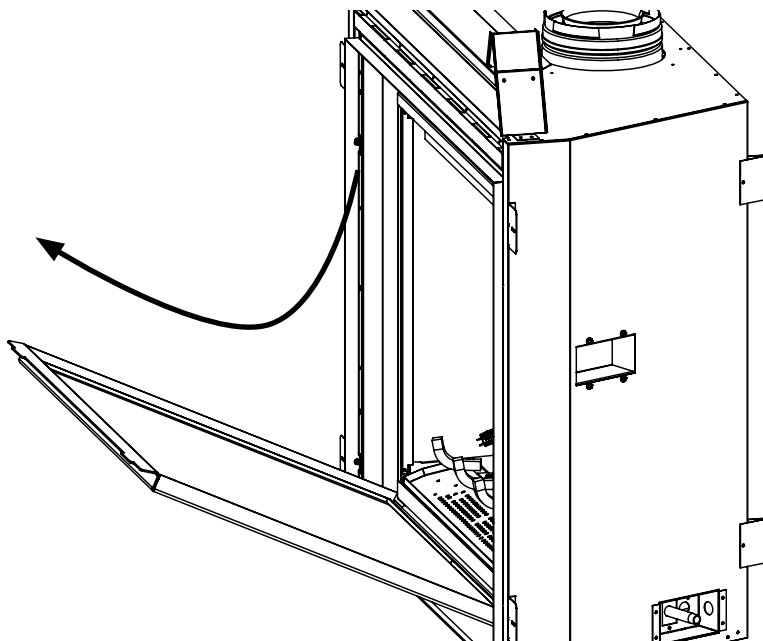


Figure 18: Glass Door - Door Removal

## Glass Door Installation:

1. Insert the bottom flange of the door frame into the retainer underneath the fireplace opening.
2. Stand the glass door up flat against the fireplace and pull the spring latches forward, up and over the door tabs.

# MAINTENANCE & SERVICE

## QUALIFIED INSTALLERS ONLY

### PILOT LIGHT:

The pilot light is set at the factory and should not need to be adjusted. The pilot light should cover  $\frac{3}{8}$ " to  $\frac{1}{2}$ " (10 to 13mm) of the flame sensor (see Figure 19). However, should the need arise, turn the adjustment screw to alter the pilot gas flow. See INITIAL INSTALLATION - GAS LINE CONNECTION AND TESTING for the location of the adjustment screw.

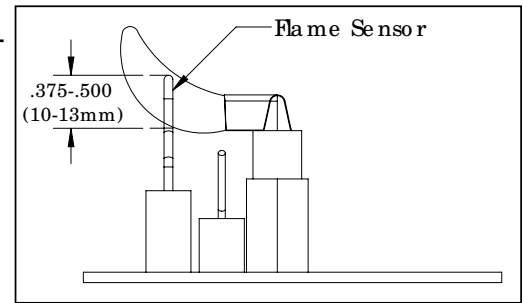
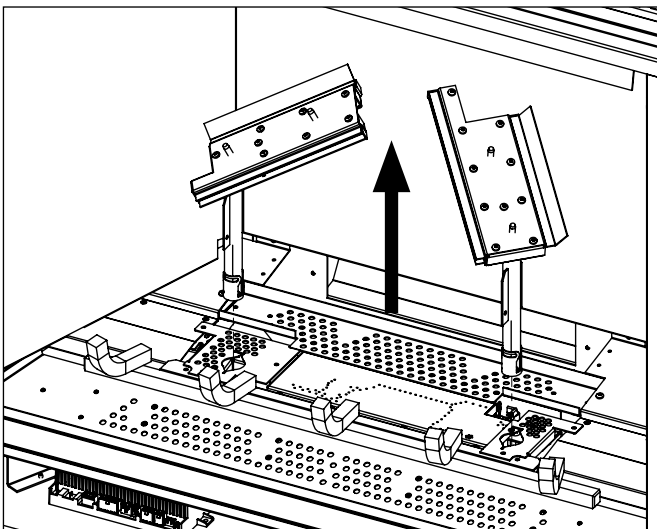


Figure 19: Pilot Light

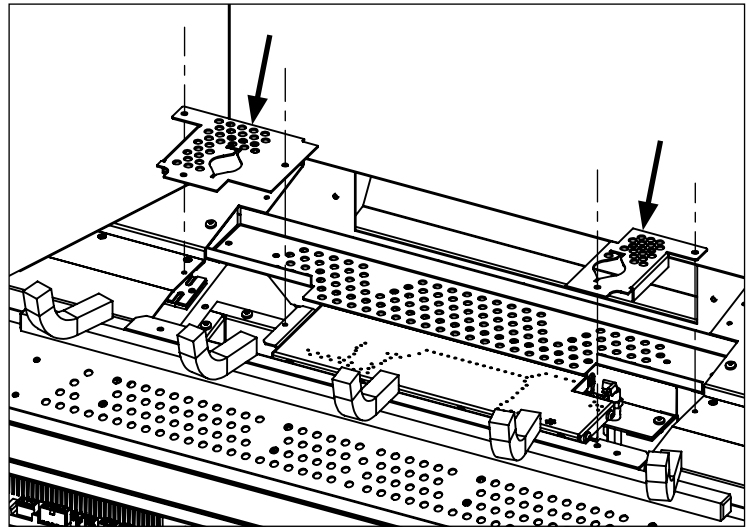
### BURNER & LOG GRATE REMOVAL:

The burners will need to be removed for maintenance and fuel conversion, also liner removal or installation. Follow the procedure carefully. **Proceed only when the unit has completely cooled down.**

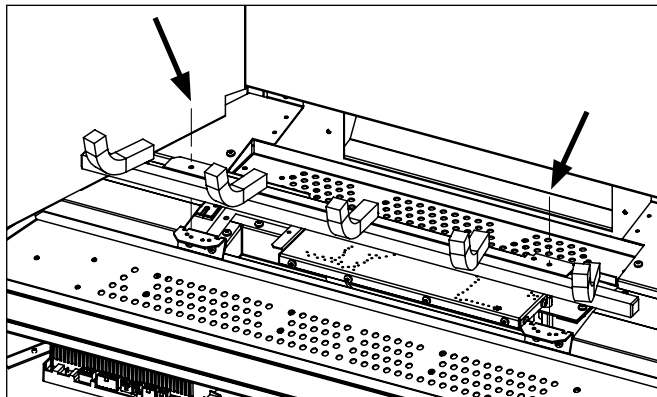
1. Remove the surround (see ANNUAL MAINTENANCE - SURROUND REMOVAL).
2. Remove the glass door (see ANNUAL MAINTENANCE - GLASS DOOR REMOVAL)
3. Remove log set and burner pan media (if installed). Front and rear ember tray media can remain in place.



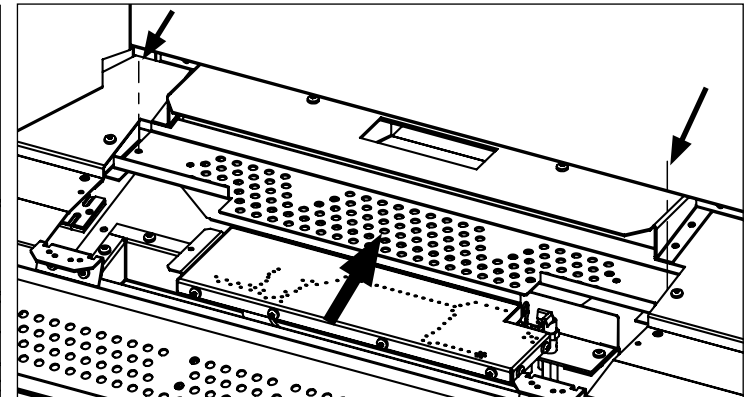
4. Remove the left and right elevated burners by simply lifting them up as shown above.



5. Next, remove the burner side covers using a Torx T20 screwdriver. The left side cover has three (3) screws and the right side cover has two (2) screws.



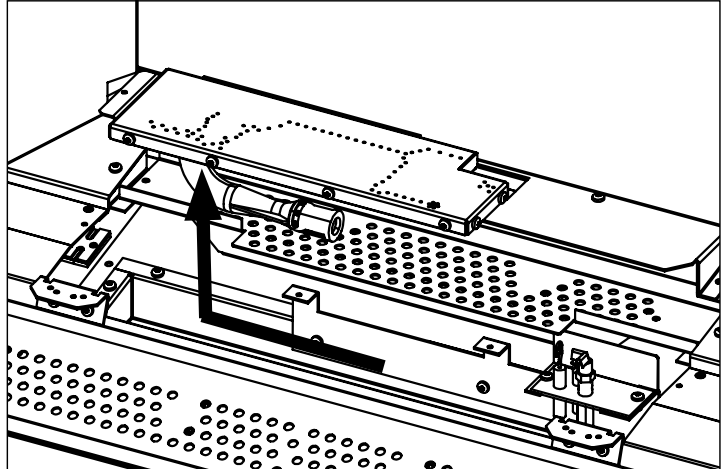
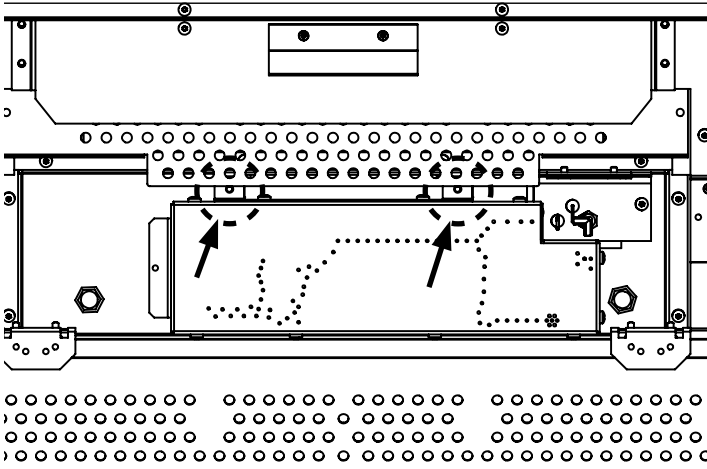
6. The log grate is removed next by unscrewing the two (2) Torx T20 screws as shown above.



7. Remove the two (2) outer Torx T20 screws from the rear ember tray and slide it back until it stops.

# MAINTENANCE & SERVICE

## QUALIFIED INSTALLERS ONLY



8. The rear burner pan mount should now be accessible. Remove the two (2) Torx T20 screws.

9. The burner pan can now be removed by first sliding it to the left and then lifting up

### AIR SHUTTERS:

The air shutters are located at the gas inlet of each burner and play a very important role in flame appearance, combustion quality and overall fireplace performance. The air shutters adjust how much air gets mixed with the gas before it ignites (called primary air). The air shutters are set at the factory but adjustments can be made to accommodate various climates, vent configurations and fuel conversions. If you cannot attain a healthy flame by making air shutter adjustments, you may have the incorrect restrictor setting or a venting issue. If the flame is very erratic, fast moving, and low then increase the restriction. If the flame is very tall, lazy, and dirty or transparent then decrease the restriction. More details can be found in the venting section of this manual.

**Normal Operation Note** - From a cold start, flames can take up to 15 minutes to achieve a desirable healthy colour and appearance.

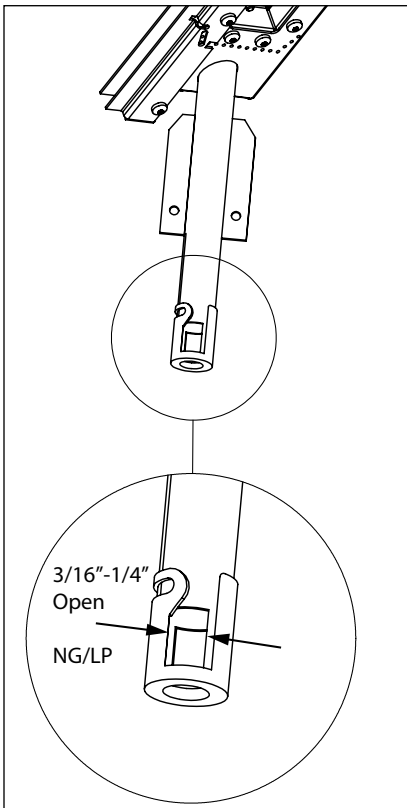


Figure 20: Elevated Burners - Air Shutter

**Caution: Wear heat resistant gloves when making adjustments to the air shutters after fireplace has been in operation.**

**Tool Required:** A #2 Phillips screwdriver is needed to adjust the burner air shutters set screw.

**Elevated Burners** - For both natural gas (NG) and propane (LP) fuels, the air shutters on the left and right elevated burners should be in the range of 3/16" - 1/4" open for the majority of installations. LP should be closer to 1/4".

**Burner Pan** - For NG fuel the burner pan shutter should be in the range of 1/16" - 1/8" open. For LP fuel the burner pan shutter should be 1/4" + open. If burner pan flames are too tall, on either fuel, the shutter can be opened more.

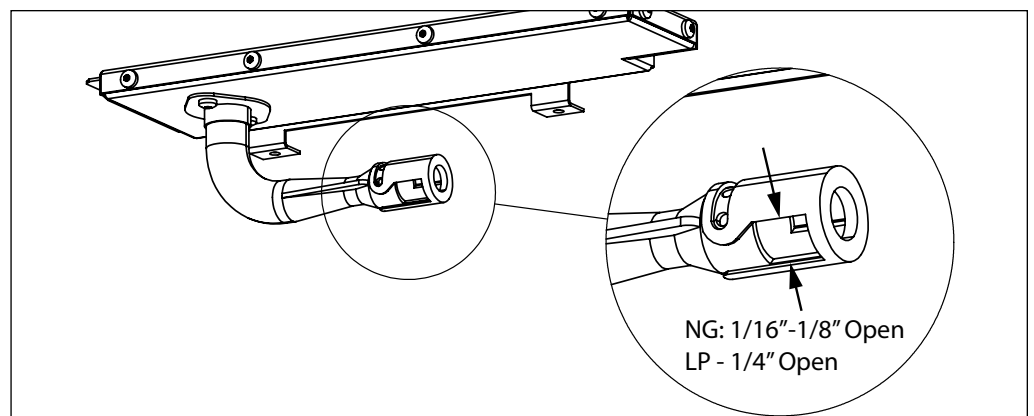


Figure 21: Pan Burner - Air Shutter

# MAINTENANCE AND SERVICE

## EMBER LIGHTS - BULB REPLACEMENT:

1. Disconnect electrical power to the unit.
2. Remove log set, elevated burners and log grate (see MAINTENANCE AND SERVICE - BURNER AND LOG GRATE REMOVAL). The burner pan can remain in place for ember light replacement.

### Front Ember Tray Removal

1. Remove all glass and coal media from the front ember tray.
2. Using a Torx T20 screwdriver, remove the six (6) retaining screws from the front ember tray.
3. Slide the ember tray forward and out of the fireplace. The front ember lights will now be accessible. There are four (4) halogen bulbs.

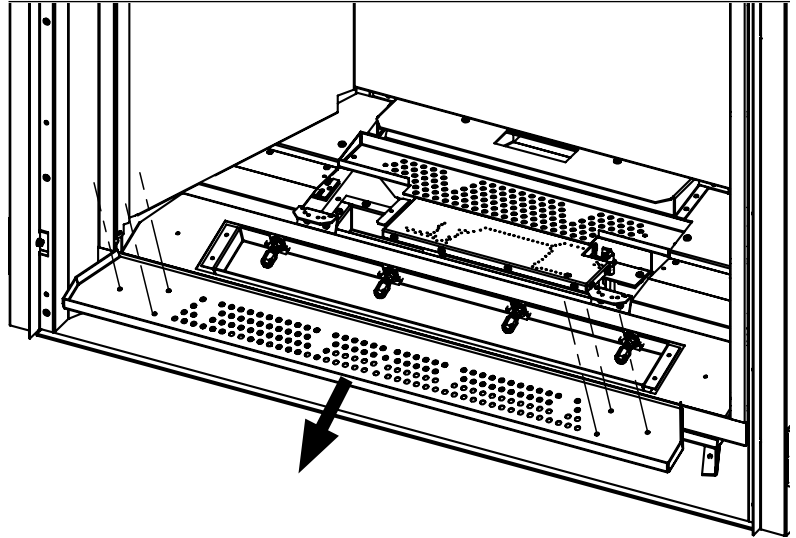


Figure 22: Front Ember Tray Removal

### Rear Ember Tray Removal

1. Remove all glass and vermiculite media from the ember tray.
2. Using a Torx T20 screwdriver, remove the four (4) retaining screws from the rear ember tray.
3. Lift the ember tray out of the fireplace. The rear ember lights will now be accessible. There are two (2) halogen bulbs.

### Halogen Bulb Replacement

4. Wear cotton gloves when replacing halogen bulbs. Grab bulb firmly at the base and pull straight out to remove; replace bulb as necessary. Grab new bulb by the foam sleeve - it is vital that your bare fingers do not contact the bulb. **The oils from your fingers will greatly reduce the life-span of the bulb.**

Halogen Bulb specifications:

GY6.35 Bi-Pin Base 120V, 35W

Enviro Part #: 50-3291

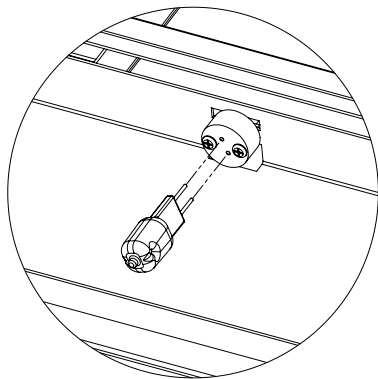


Figure 24: Halogen Bulb Replacement

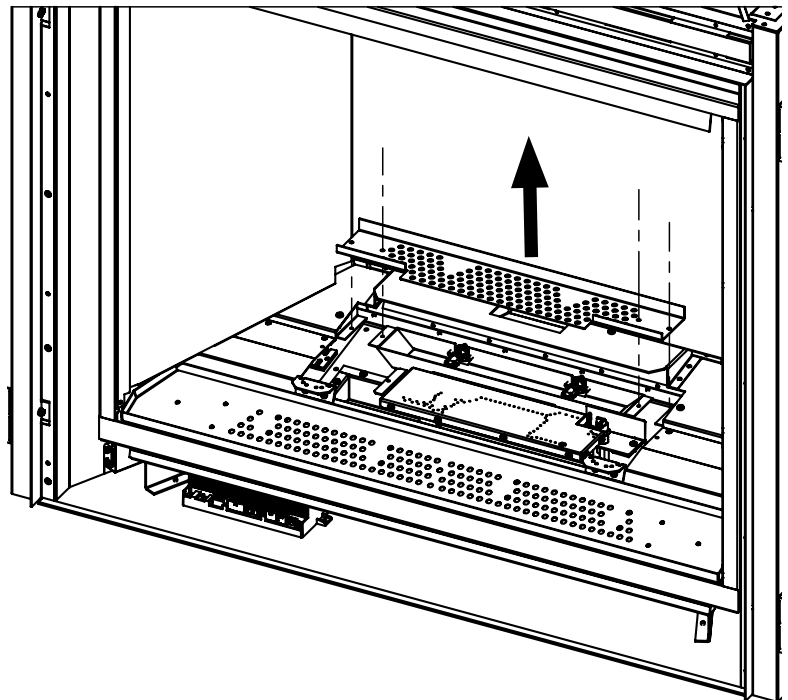


Figure 23: Rear Ember Tray Removal

5. Reconnect electrical power and confirm ember lights are operational.

# FUEL CONVERSION

**TO BE INSTALLED BY A QUALIFIED SERVICE AGENCY ONLY**

**Please read and understand these instructions before installing.**

**Warning:** This conversion kit shall be installed by a qualified service agency in accordance with the manufacturer's instructions and all applicable codes and requirements of the authority having jurisdiction. If the information in these instructions is not followed exactly, a fire, explosion or production of carbon monoxide may result causing property damage, personal injury or loss of life. The qualified service agency is responsible for the proper installation of this kit. The installation is not proper or complete until the operation of the converted appliance is checked as specified in the manufacturer's instructions supplied with the kit.

## Kit Parts List for RZ41 Model:

- 3 - Burner Orifice LP [2 x # 57, 1 x # 59]
- 1 - LP Pilot Orifice
- 1 - LP Stepper Motor w/ Hardware & Label
- 4 - Conversion Labels

## Tools Required for Fuel Conversion:

- Ratchet w/ 3/8" socket & 1/2" socket (deep preferably)
- 7/16" & 5/8" wrench
- Cordless drill with long Torx T20 driver bit

Carefully inspect all parts supplied with this conversion kit. If any parts have been damaged or are missing, contact your dealer or distributor to have them replaced before starting this installation.

## CONVERSION KIT INSTALLATION:

### 1. Disconnect the gas supply completely as well as any electrical power source before proceeding.

2. Remove the surround, glass door, log grate and burners (see ANNUAL MAINTENANCE, MAINTENANCE AND SERVICE sections of this manual).

3. Convert the existing pilot orifice with the one provided in this kit (see Figure 25) using a **7/16" wrench**. Fully unscrew and remove the pilot head and replace the orifice insert, bell end down. Re-install and tighten the pilot, if the head does not reach proper orientation in the snug position then contact your Enviro dealer.

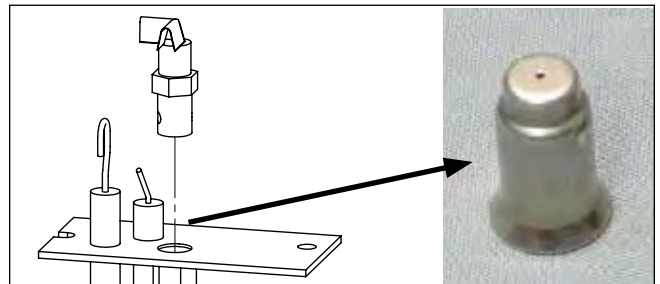


Figure 25: Pilot Orifice (not to scale)

4. Convert the burner pan orifice with the one provided in this kit using a **ratchet and 3/8" socket** (figure 26).

5. Convert the elevated burner orifices with the ones provided in this kit using a **ratchet with a 1/2" deep socket and a 5/8" wrench**. Use the 5/8" wrench to hold the base nut of the burner orifice while using the 1/2" deep socket to remove the orifice (figure 27 & 28). The left and right elevated burners have the same orifice size.

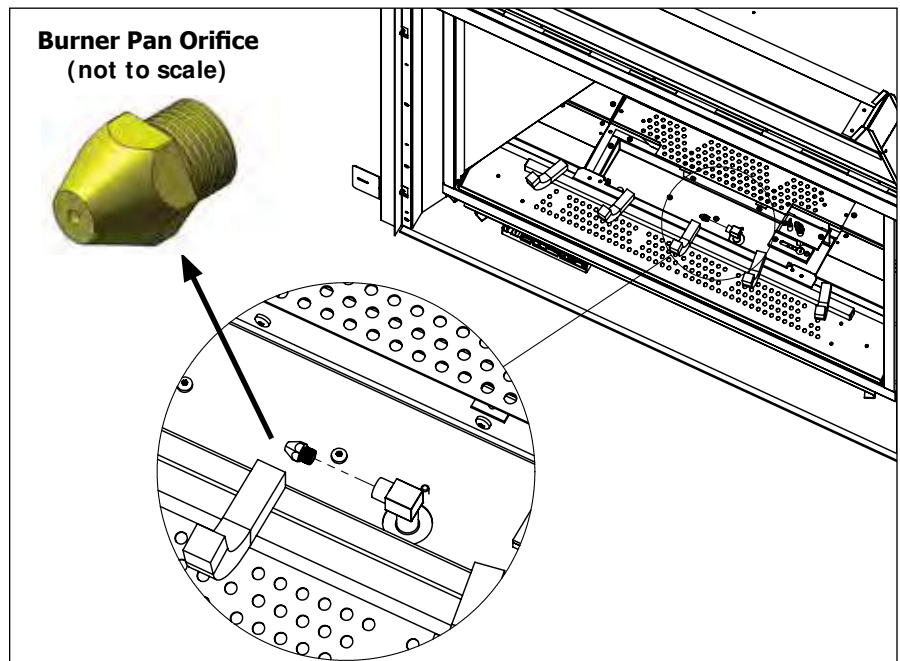
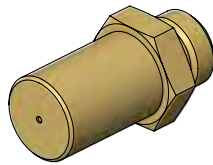
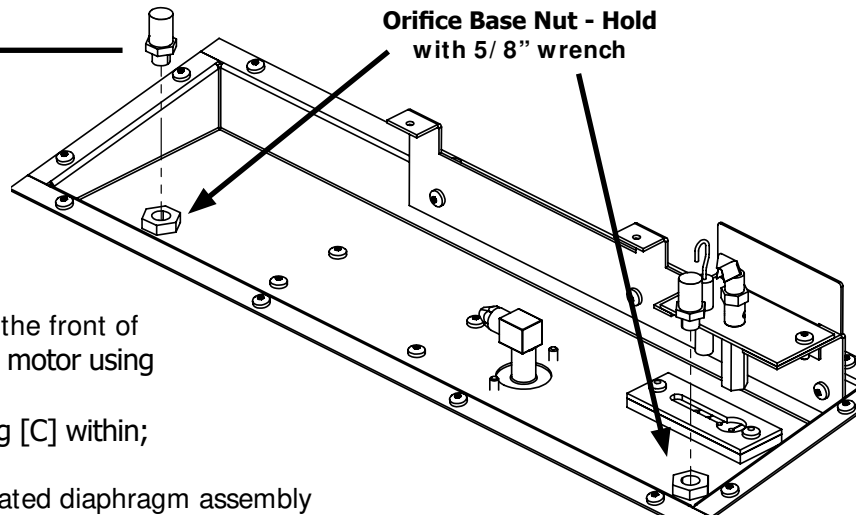


Figure 26: Burner Pan Orifice Location

# FUEL CONVERSION

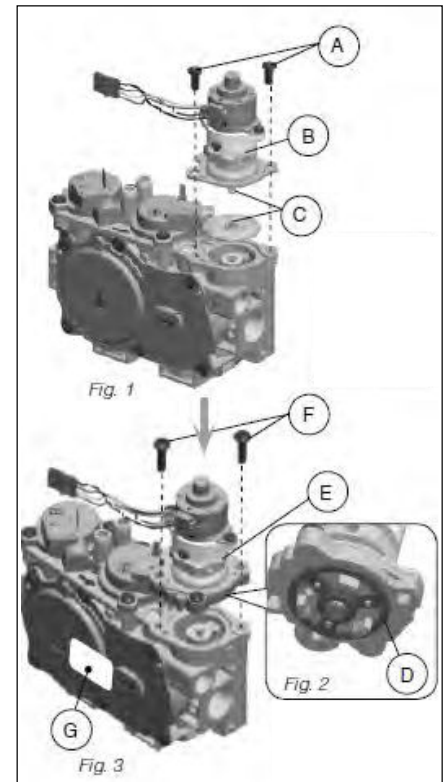


**Figure 27: Elevated Burner Orifices (x2)**  
(not to scale)



**Figure 28: Elevated Burner Orifice locations**

6. Convert the SIT gas valve (figure 29):
  - a) Locate the gas valve directly underneath the front of the firebox and remove the existing stepper motor using a T20 screwdriver [A & B].
  - b) Remove the rubber diaphragm and spring [C] within; **DO NOT REUSE.**
  - c) Install the new stepper motor with integrated diaphragm assembly [D & E] using the longer T20 screws supplied [F].
  - d) Adhere the supplied SIT conversion label [G] to the valve body.
  - e) Plug the new stepper motor into the X6 port of the IFC.
7. Reinstall the burners, log grate, burner pan media, logs set, glass door and surround (see ANNUAL MAINTENANCE, MAINTENANCE AND SERVICE sections of this manual).
8. Purge any air from gas line and reconnect to unit.
9. Use a small brush and apply a warm soapy water solution to all gas connections. If a gas leak is present, bubbling will occur. Gas leaks can be repaired by using a gas approved pipe thread sealant. **WARNING: NEVER USE AN OPEN FLAME WHEN TESTING FOR GAS LEAKS.**
10. Reconnect electrical power to the unit.
11. Light the pilot and recheck for leaks in the aluminum pilot line. If a leak is evident, contact your ENVIRO dealer for a pilot line replacement. **WARNING: DO NOT ATTEMPT TO FIX THIS LINE, IT MUST BE REPLACED IF DAMAGED.** The pilot should properly cover the flame sensor. See MAINTENANCE AND SERVICE - PILOT LIGHT SECTION of this manual.
12. Start the main burner and verify full range of adjustment using the remote. Confirm the inlet and manifold gas pressures are within the acceptable range using a manometer (see INITIAL INSTALLATION - GAS LINE CONNECTION AND TESTING). If this unit has been installed at an altitude higher than 2000ft (610m) it is required to de-rate the unit accordingly.



**Figure 29: SIT Valve Conversion**

**In the USA:** The appliance may be installed at higher altitudes. Please refer to your American Gas Association guidelines which state: the sea level rated input of Gas Designed Appliances installed at elevations above 2000 (610 m) feet is to be reduced 4% for each 1000 feet (305 m) above sea level. Refer also to local authorities or codes which have jurisdiction in your area regarding the de-rate guidelines.

**In Canada:** When the appliance is installed at elevations above 4500 feet (1372 m), the certified high altitude rating shall be reduced at the rate of 4% for each additional 1000 feet (305 m).

13. **MAKE SURE** that the conversion labels provided are installed on or close to the rating label to signify that the unit has been converted to a different fuel type.

# INITIAL INSTALLATION

## QUALIFIED INSTALLERS ONLY

### INTRODUCTION:

This section of the owner's manual is for the use of qualified technicians only. There are several installation safety guidelines that must be adhered to; carefully read the safety precautions at the front of this manual.

### UNIT INSTALL PREPARATION:

Review the diagram below to familiarize yourself with the parts included with the unit. Please review the following instructions carefully to ensure the unit is prepared properly before installation.

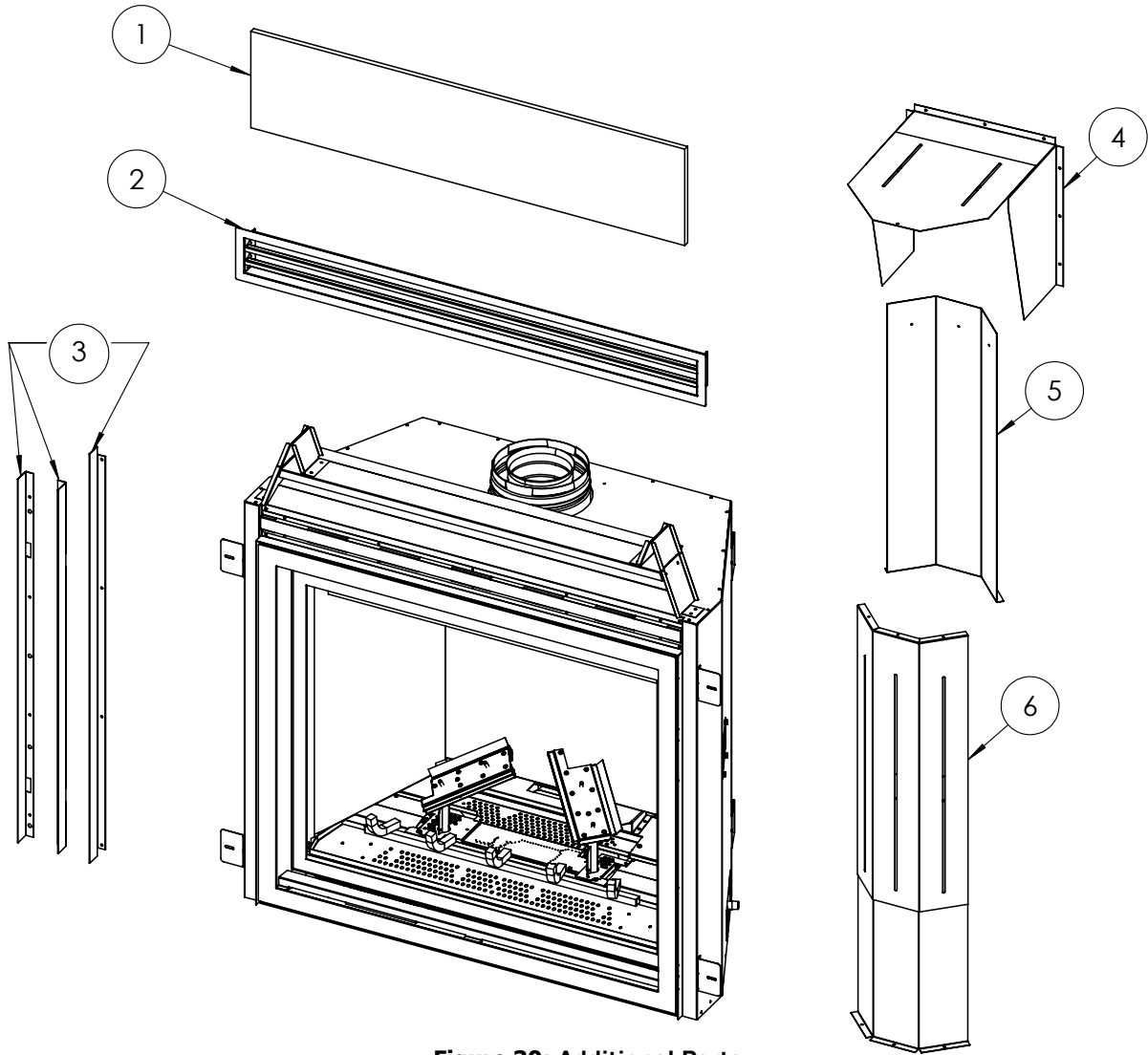


Figure 30: Additional Parts

Table 2: Additional Parts

Item Number	Item Description	Quantity
1	Non-Combustible Board	1
2	Cool Surface System Bezel	1
3	Long Finishing Trim Set - 3 Pcs (Left, Right, Top)	1
4	Adjustable Thimble Shield (1 bend flattened for packaging)	1
5	Rear Vertical Vent Shield	1
6	Front Adjustable Vertical Vent Shield	1

# INITIAL INSTALLATION

## QUALIFIED INSTALLERS ONLY

### Nailing Flanges:

There are four (4) nailing flanges to secure the unit to the framing, they are assembled flat from the manufacturer. Remove the upper Torx T20 screw and rotate each nailing flange upward until the bare nailing flange hole lines up and reinstall the Torx T20 screw. Bend the flange 90 degrees making it flush with the cabinet face.

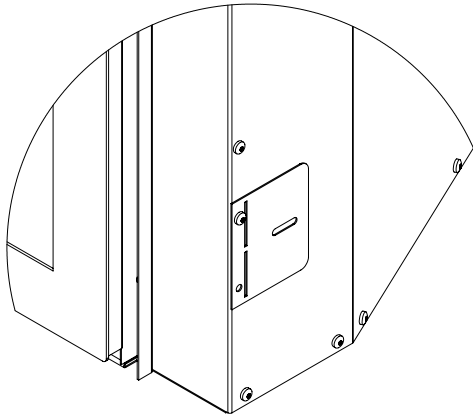


Figure 31: Nailing Flange Flat

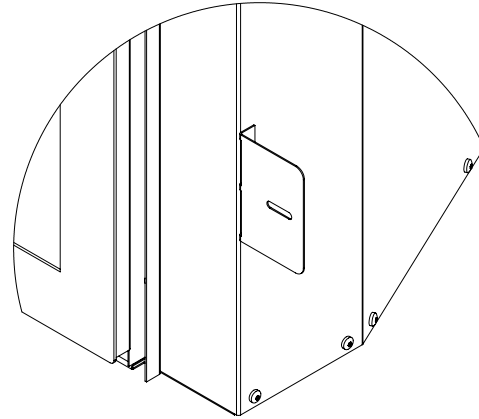


Figure 32: Nailing Flange Assembled

### Top Standoffs:

Bend the top standoffs, by hand, into a tent shape

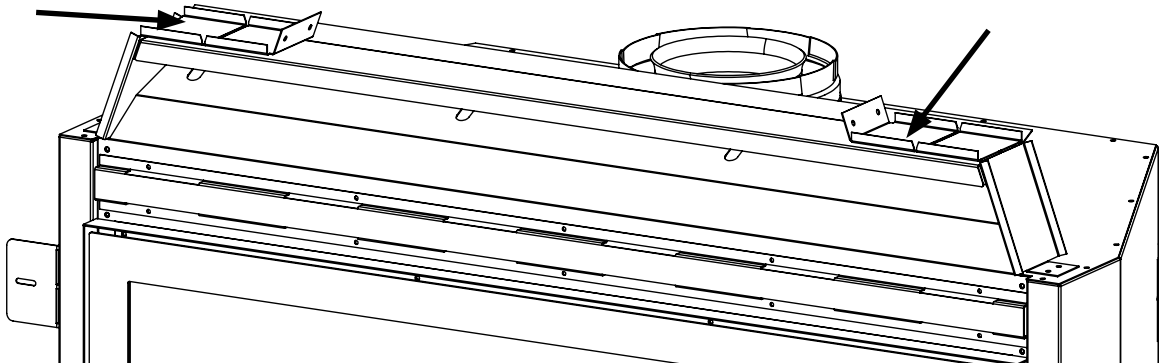


Figure 33: Top Standoffs - Unfolded (as shipped)

Fasten them to the header shield using the four (4) pre-installed Torx T20 screws

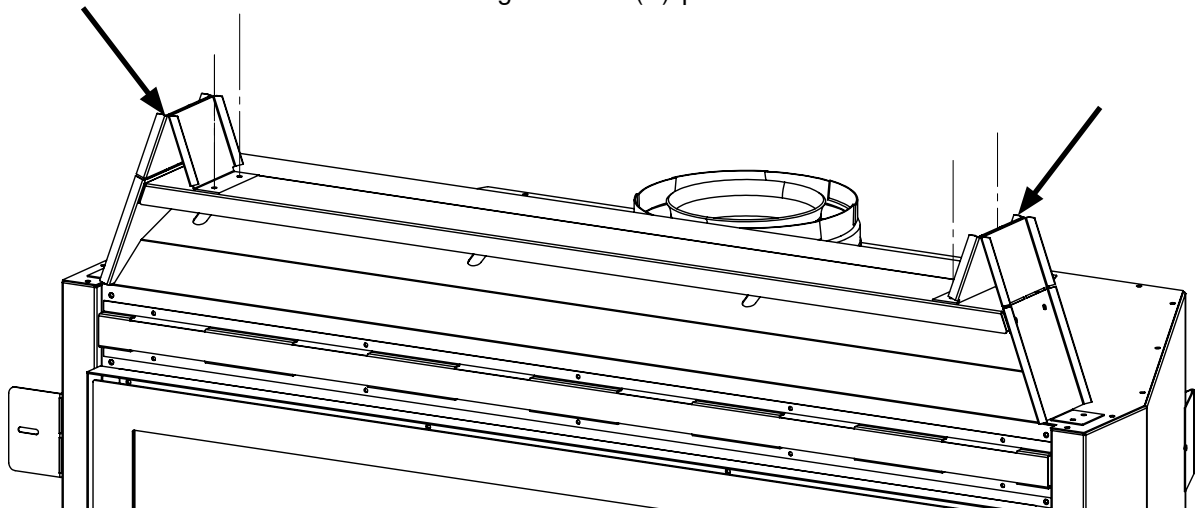


Figure 34: Top Standoffs - Assembled

# INITIAL INSTALLATION

## QUALIFIED INSTALLERS ONLY

### Non-combustible board:

Install the supplied non-combustible facing board above the fireplace as shown below. **CAUTION: TAKE CARE TO NOT SINK SCREW HEADS TOO DEEP INTO THE BOARD OR IT MAY CRACK.** This board is mandatory unless the COOL SURFACE SYSTEM is activated, if it is damaged contact your ENVIRO dealer.

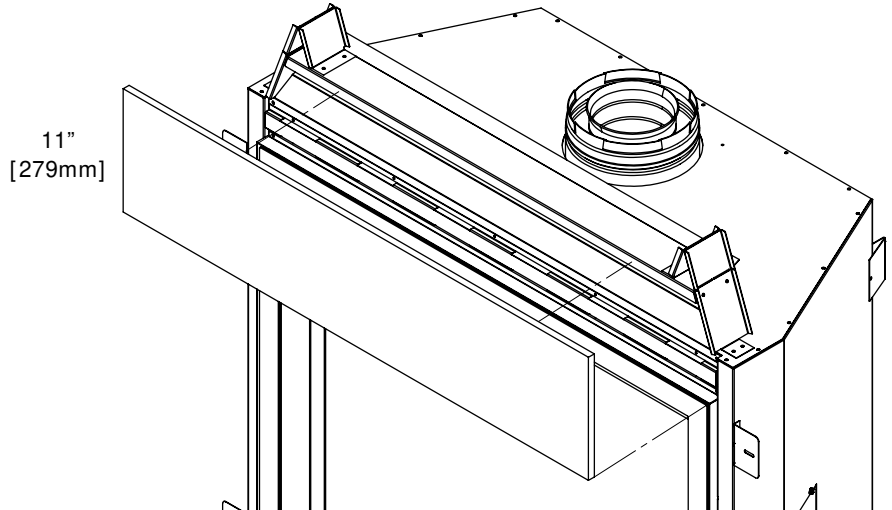


Figure 35: Non-combustible board

### Finishing Trims:

The RZ41 comes with two different sized finishing trims. The fireplace comes with a short finishing trim set installed and a second long finishing trim set comes packaged with the fireplace:

**Short Finishing Trim** - This finishing trim comes mounted to the unit with screws. This finishing trim is 5/8" deep. Finishing material thicker than 5/8" will sit proud of the trim edge.

**Long Finishing Trim** - This finishing trim comes wrapped in foam on top of the unit. This finishing trim is 1" deep to accommodate finishing materials of 3/4" or more in thickness. Finishing material thicker than 1" will sit proud of the trim edge. The Short Finishing Trim Set installed on the fireplace will need to be removed and replaced with this set. This is ideal for thicker finishes like stone.

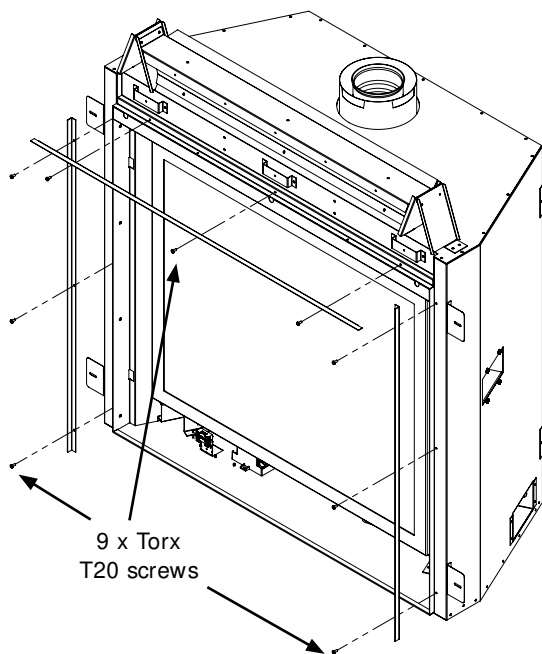


Figure 36: Outer finishing edge removal / replacement

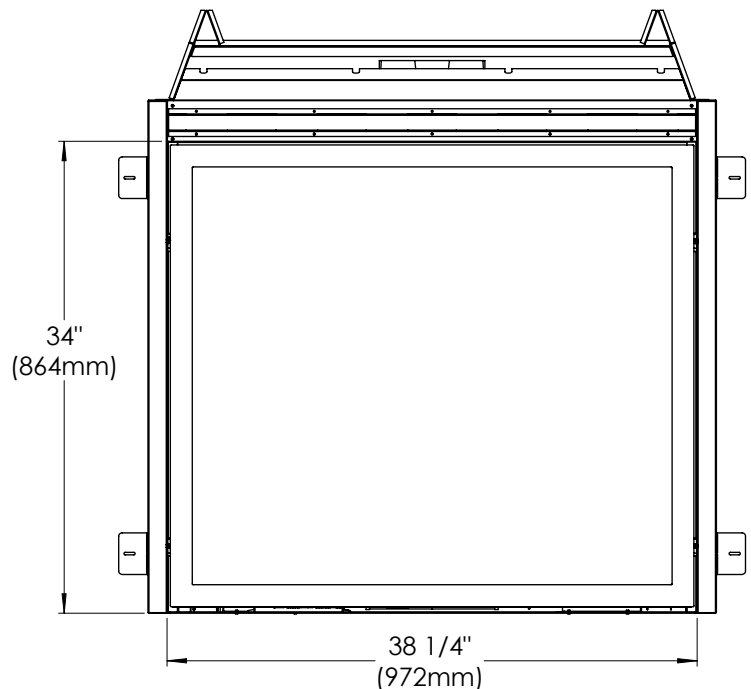


Figure 37: Outer finishing edge dimensions

# INITIAL INSTALLATION

## QUALIFIED INSTALLERS ONLY

### PLACEMENT AND FRAMING:

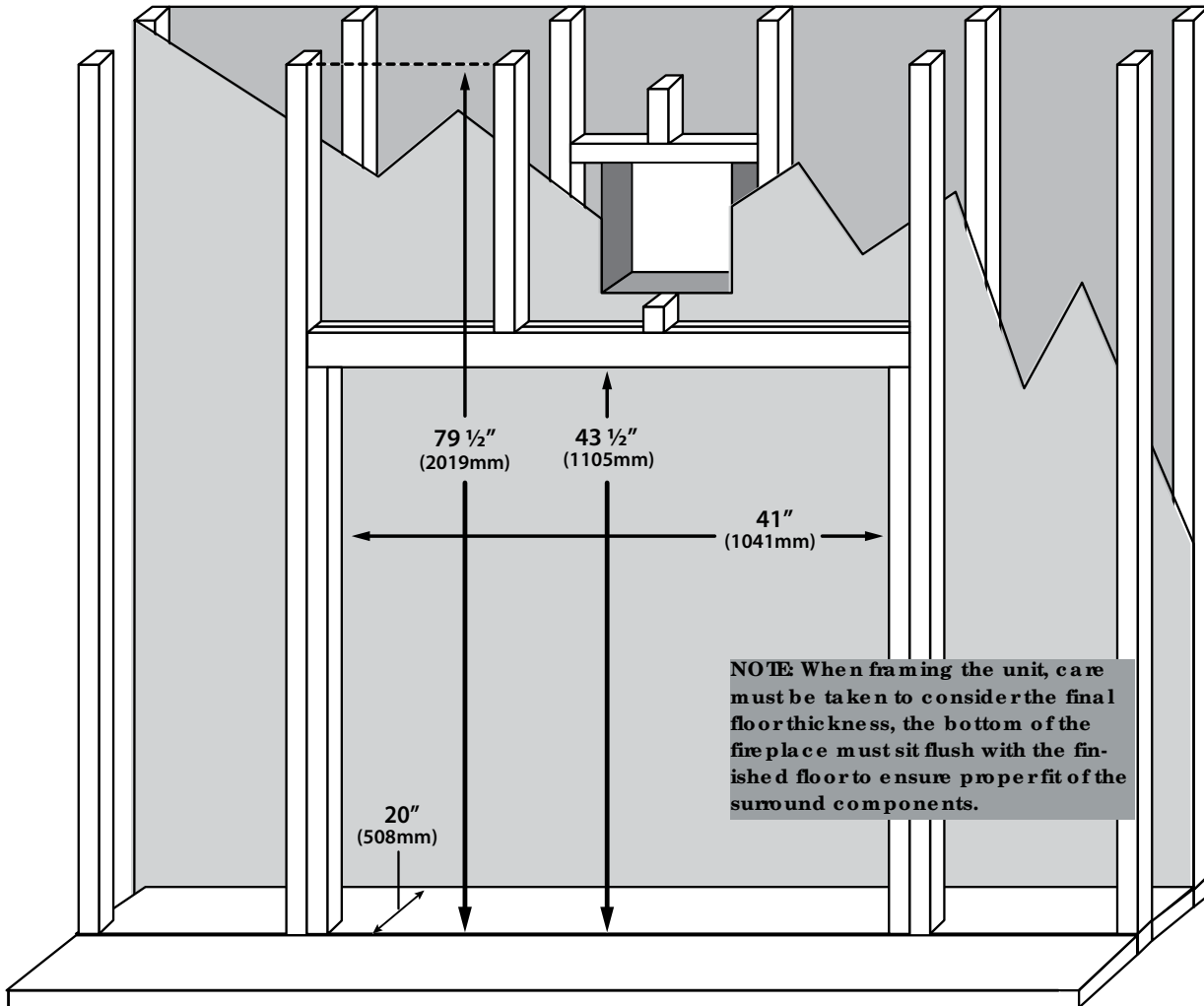


Figure 38: RZ41 Minimum Framing

Table 3: RZ41 Minimum Framing

Minimum Framing Dimensions		
Depth	20"	508mm
Width	41"	1041mm
Header Height	43 1/2"	1105mm
Enclosure Ceiling	79 1/2"	2019mm

The location for the fireplace can be raised, at floor level, or installed in a corner. There are minimum framing measurements for each situation. The basic rough opening should have the following dimensions (see Figure 38). The fireplace must be placed on a strong and level surface.

The gas line must be run to the right side of the fireplace, there is a 3/8 NPTM fitting to connect the gas line to. The electrical wiring must be brought to the left side. The location of the fireplace should be chosen so there will be at least a **36 inches (914 mm)** clearance from drapes, doors and other combustible materials.

# INITIAL INSTALLATION

## QUALIFIED INSTALLERS ONLY

### CLEARANCES & NON-COMBUSTIBLE :

When installing the fireplace as a zero clearance fireplace the correct clearances and materials must be used.

**ABOVE UNIT:** The supplied noncombustible board is required above the unit up to the header 11" MIN.

However this not required if the Cool Surface System has been properly installed.

**HEADER:** The header can be made up of wood 2x4 construction at or above the top standoffs. Steel studs are not required.

**BELOW UNIT:** Is is recommended the fireplace sit a solid and level piece of 3/4" plywood.

**SIDEWALL / MANTEL LEG:** There must be a minimum distance of 1" (25.4mm) from the finishing edge of the fireplace to an adjacent side wall or mantle leg composed of combustible material.

**FRONT WALL:** There must be a minimum distance of 36" (914mm) from the front of the fireplace to another wall composed of combustible material directly in front of the fireplace.

**MANTEL:** It is not necessary to install a mantel, but if one is desired the guidelines as shown in "INITIAL INSTALLATION - MANTEL CLEARANCES".

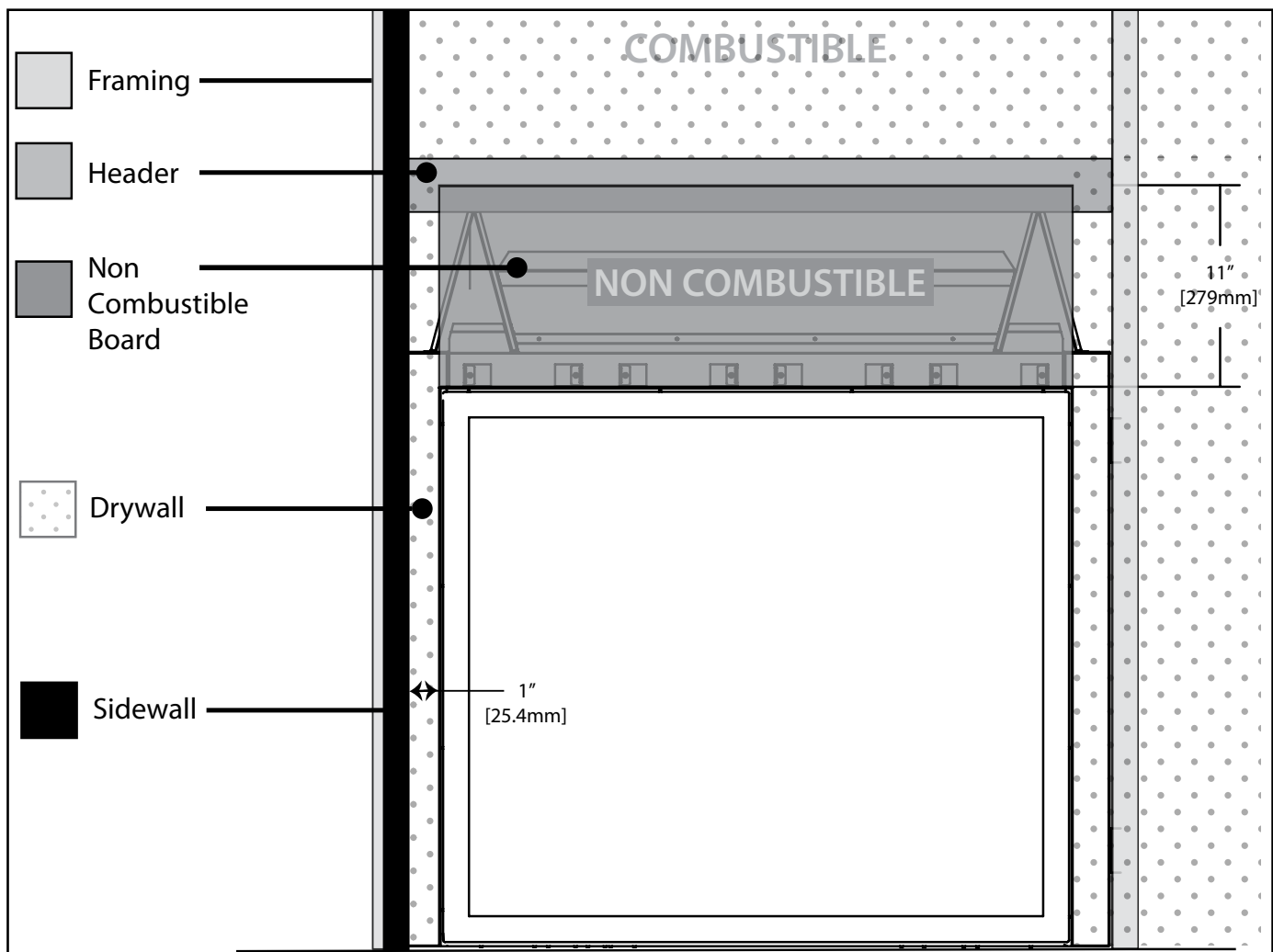


Figure 39: Typical Facing Layout

# INITIAL INSTALLATION

## QUALIFIED INSTALLERS ONLY

### FLOORING:

The fireplace must be placed on a solid and level floor; plywood is recommended for basic installations. A protective hearth in front of the unit is not required but highly recommended for the longevity of sensitive flooring materials in front of the fireplace. Since every home and installation is unique, temperatures should be verified at the time of installation to confirm the manufacturer's maximum allowable temperature isn't exceeded.

If masonry is to be used, prepare the necessary foundation for the masonry load. When masonry construction is being used, a lintel must be used over top of the fireplace to support the added weight.

Consider the height of hearth finish material (stone, brick, etc.) when building a fireplace platform. The bottom of the fireplace must be level with finished hearth.

**LVP / LVT FLOORING CLEARANCE:** LVP / LVT flooring is not permitted directly in front of the fireplace and must be a **minimum 24" (610mm)** away from the front of the fireplace, the full width of the fireplace. Floating type vinyl flooring is recommended versus adhesive type but it may still experience temperatures in excess of 120°F. Floor temperatures should be confirmed prior to vinyl floor installation to confirm the manufacturer's maximum allowable temperature isn't exceeded. Due to installation variables and the low temperature nature of vinyl flooring, Sherwood Industries is not responsible for any damage or discolouring caused by the fireplace.

### MANTEL CLEARANCES:

First determine what mantel height or depth you would like and use the graph below (figure 40) to determine the minimum clearance required. Mantel graph dimensions are measured from the top of the fireplace opening, if you wish to reference the mantel height from the floor, add 34" (864mm) to the mantel height depicted on the graph. If you plan to install a TV above your fireplace refer to the appropriate section for available options. **If you are using the Cool Surface System (CSS) the minimum mantel clearances can be greatly reduced.** Refer to the graph on the following page (figure 41).

**Note** - If using a **non-combustible mantle**, without CSS, 1 ¼" (32mm) may be subtracted from the clearances shown in the chart below.

### Minimum Combustible Mantel Clearances

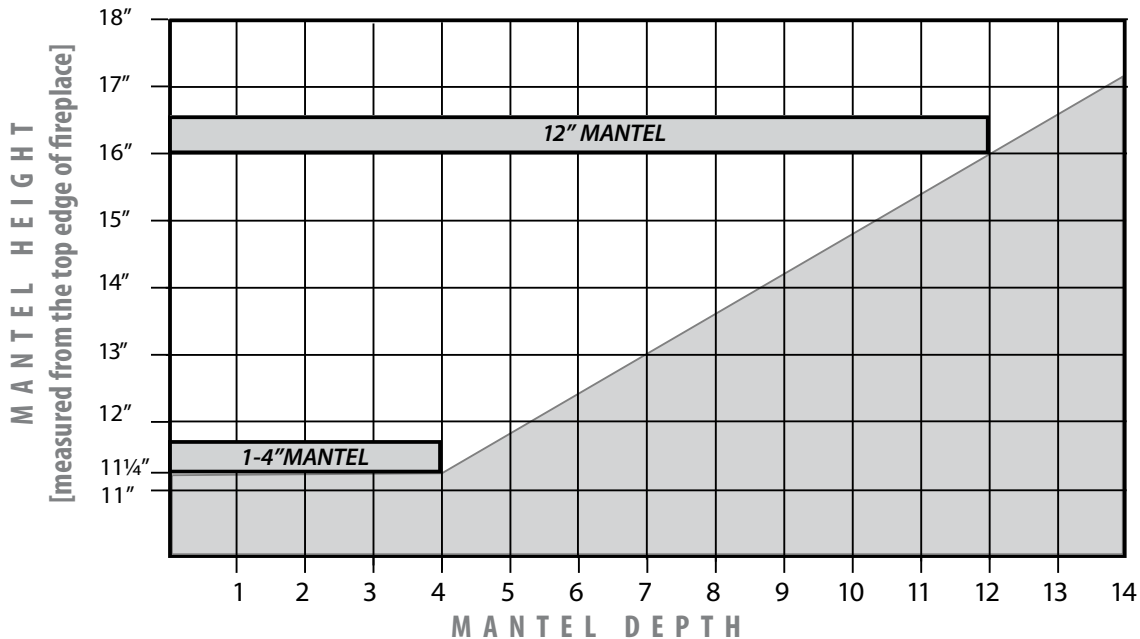


Figure 40: Mantel Graph

# INITIAL INSTALLATION

## QUALIFIED INSTALLERS ONLY

### Minimum Cool Surface System Mantel Clearances

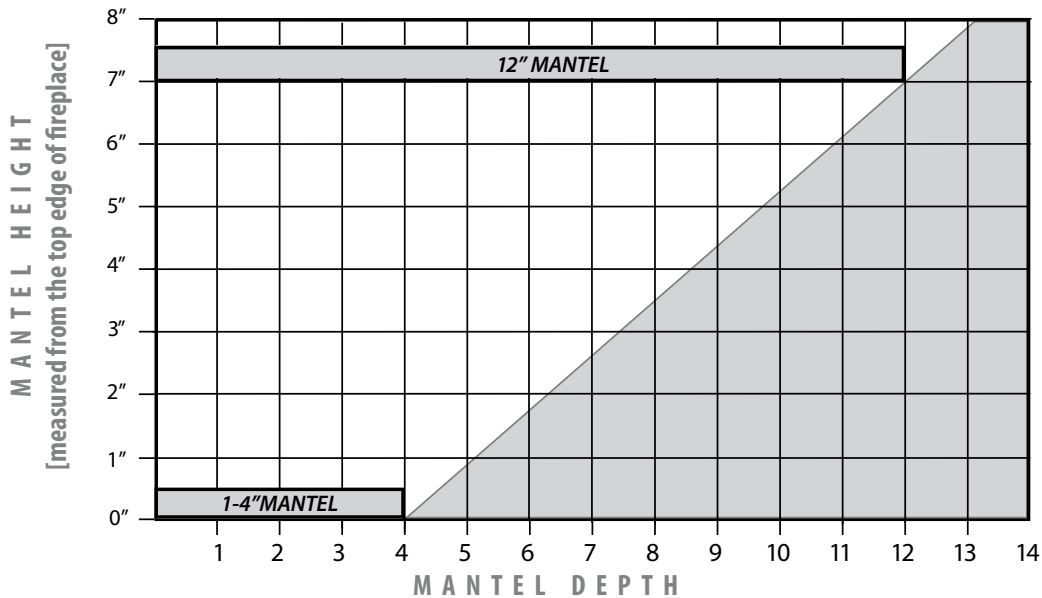


Figure 41: CSS Mantel Graph

### COOL SURFACE ACTIVATION:

**WARNING: IT IS ESSENTIAL THAT THE CHASE IS VENTED IN A MANNER THAT RELIEVES THE ADDITIONAL HEAT ENTERING THE CHASE. ENSURE ONE OF THE AVAILABLE FRAMING OPTIONS HAVE BEEN CONSTRUCTED IN ACCORDANCE WITH THIS MANUAL. FAILURE TO DO SO CAN CREATE AN OVERHEATING SITUATION THAT COULD LEAD TO BUILDING FIRE.**

Ensure your chase has been constructed in a manner that vents the chase into the same room. It is not permitted to vent the chase into an adjoining room. The CSS bleeds heat off the fireplace into the chase as opposed to climbing up the front face. This dramatically lowers the front wall temperatures allowing the placement of delicate objects above the fireplace. Review the guidelines in the previous sections to ensure your install is in accordance with the framing specifications. Follow these instructions to activate the CSS feature. The non-combustible board included with the fireplace is no longer required when using CSS.

**CSS Activation** - Remove CSS plug using a Torx T20 screwdriver.

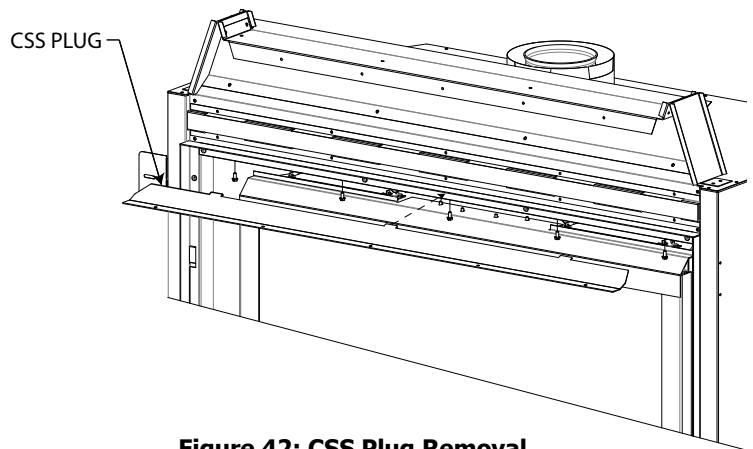


Figure 42: CSS Plug Removal

### FINISHING THE FIREPLACE:

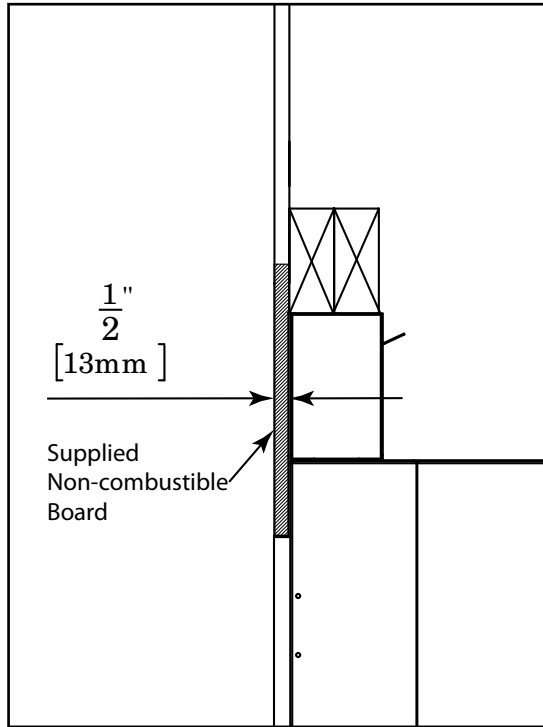
**Combustible material may be brought up to any finishing edge ONLY if the Cool Surface System (CSS) has been correctly activated allowing heat in the chase to be vented.** This system keeps the front wall cool enough for any combustible materials. The supplied non-combustible board can still be used but is not mandatory when the CSS is activated, combustible material may overlap in this situation.

**If the CSS has NOT been activated (Traditional Install) you MUST use a non-combustible material directly above the fireplace extending up the front wall 11" from the top finishing edge,** it is recommended to use the supplied non-combustible board. Combustible material must **NOT** be brought up to the top finishing edge. Also combustible material **CANNOT** overlap the non-combustible board on a traditional installation.

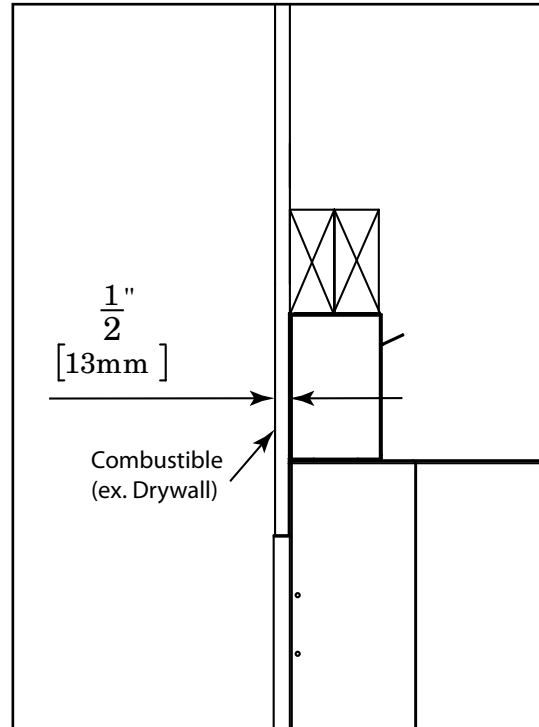
# INITIAL INSTALLATION

## QUALIFIED INSTALLERS ONLY

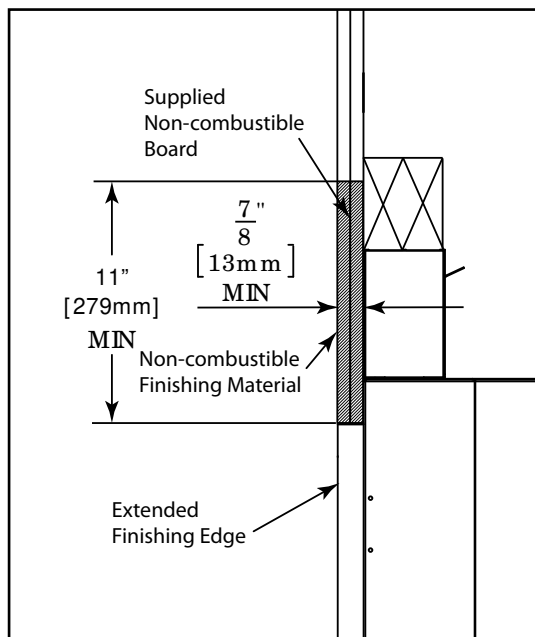
**Standard Install:** the **Non-combustible** is mandatory. Image shows single layer finishing material using the short finishing edge.



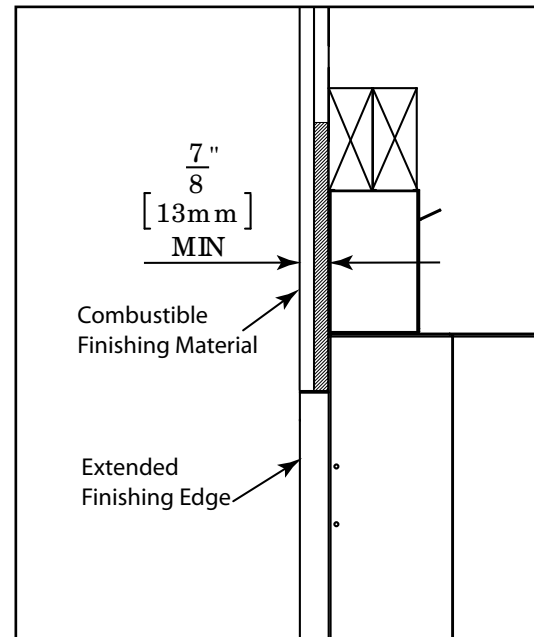
**Cool Surface System (CSS) Install:** Image shows the short finishing edge, **combustible** can be brought right down to the finishing edge.



**Standard Extended Install:** Using the supplied long finishing edge, **non-combustible** material may be layered on top of the supplied Non-combustible board. Supplied board not needed for thick **non-combustible** finishes like rock.



**Cool Surface System Extended Install:** Using the supplied long finishing edge, **combustible** material may be layered on top of the supplied Non-combustible board. Supplied board is not needed for thicker **combustible** finishes.



# INITIAL INSTALLATION

## QUALIFIED INSTALLERS ONLY

### COOL SURFACE INSTALL OPTIONS:

This fireplace is manufactured with a built-in heat distribution kit, referred to as the Cool Surface System (CSS). The purpose of the CSS is to dramatically reduce the front wall temperatures above your fireplace. This is very useful when delicate objects such as a TV or artwork are mounted above the unit. Using this feature will also allow you to use combustible facing materials right up to the finishing edge. It is extremely important these instructions are followed meticulously. If not installed correctly this could be very dangerous and could lead to building fire. If the CSS is activated it is crucial that the chase is vented in accordance to this manual. There are a few different options available to finish the CSS.

#### Clearances:

- CSS openings must be at least 60" (152 cm) away from the nearest fire sprinkler head.
- A wall directly in front of any front CSS opening must be at least 36" (96 cm) away.

**Option 1: Front Discharge (flush wall installations)** - Construct the framing in a way that provides a minimum 41inch (1054mm) by 3½ inch (89mm) gap at the top of the facing wall. It is essential that these dimensions are respected and not deviated away from them when using combustible materials inside or outside the chase (see Figure 43).

**Option 2: Front Bezel** - The included bezel may be desired to accentuate the front discharge (figure 45). This installation will also cover the edge of the finishing material at the cutout. The top of the cutout cannot be more than 1 1/2" from the top of the chase (figure 44). It is essential that these dimensions are followed and not to deviated from them when using combustible materials inside the chase.

**Note:** If you wish to construct the CSS air discharge part way up a tall wall then it is essential to build a false ceiling inside the chase at the desired height to direct the rising heat out of the gap.

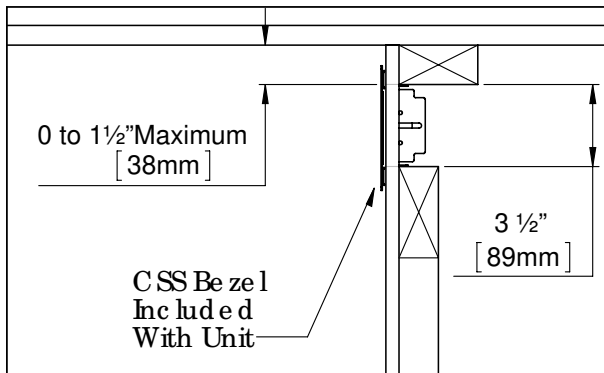


Figure 44: Option 2 Front Bezel

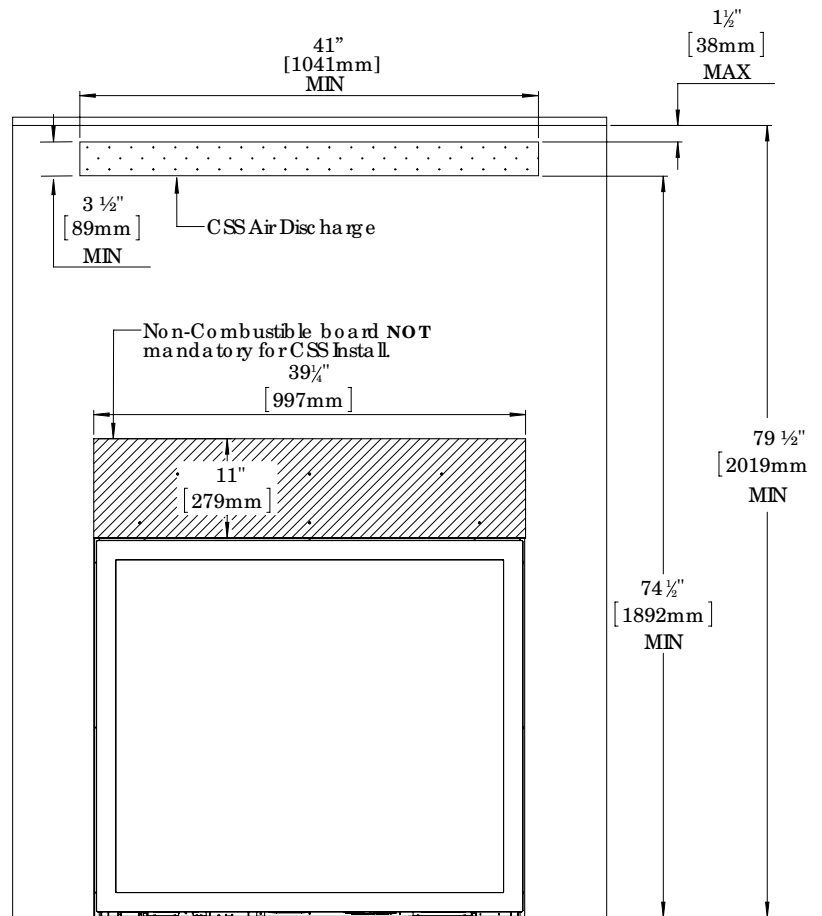


Figure 43: Options 1 Front Discharge

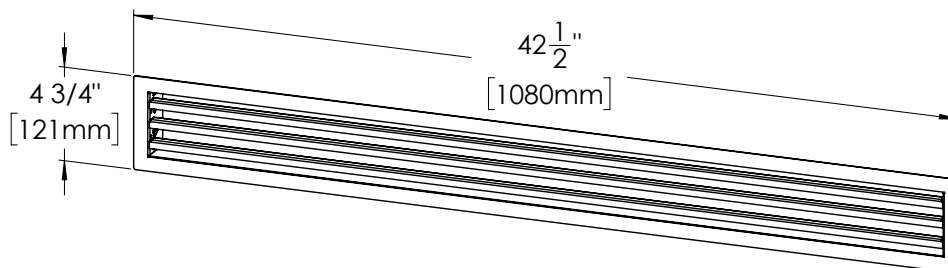


Figure 45: Front Bezel Iso View

# INITIAL INSTALLATION

## QUALIFIED INSTALLERS ONLY

**Optional: False Ceiling** - If your ceiling dimension is greater than the minimum (figure 47) You may want the CSS Air discharge lower on the wall. To do this a false ceiling is required to properly evacuate the heat from the chase (figure 46).

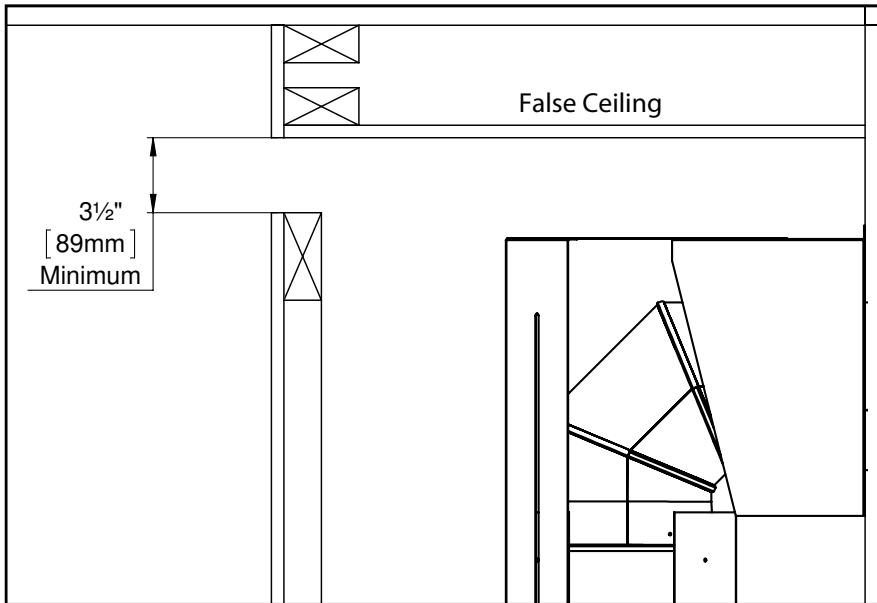


Figure 46: False Ceiling

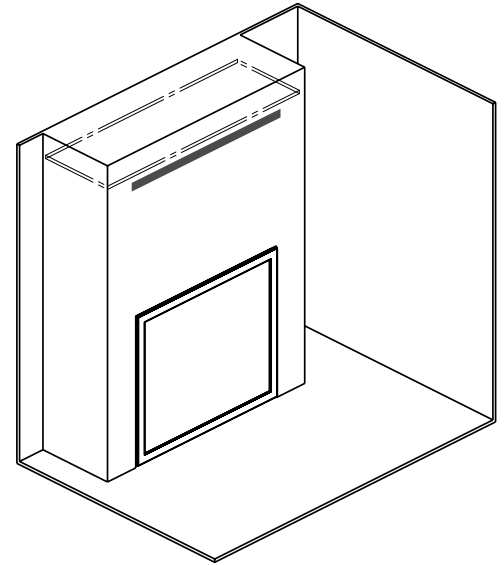


Figure 47: False Ceiling Iso View

**Option 3: Side Discharge (built-out installations)** - Construct the framing in a way that provides a minimum 17" (432mm) wide by 4 1/4" (64mm) tall opening on each side of the chase. The top of the opening must be no more than 1 1/2" (38mm) from the top of the chase (see Figure 48 & Figure 49). For installations deeper than minimum depth, the side discharge may be reduced to 20 5/8" (524mm) wide by 3 1/2" (89mm) tall. Aftermarket louvers/grills may also be used to accentuate the openings but their restriction must be accounted for. **Minimum free open area, per side, must be no less than 72 1/4 in<sup>2</sup> (466 cm<sup>2</sup>).**

- Side CSS openings must be at least 60" (152 cm) away from the nearest fire sprinkler head.
- A wall directly in front of any side CSS opening must be at least 16" (406mm) away

**Note:** If you wish to construct the CSS air discharge part way up a tall wall then it is essential to build a false ceiling inside the chase at the desired height to direct the rising heat out of the gap. See above.

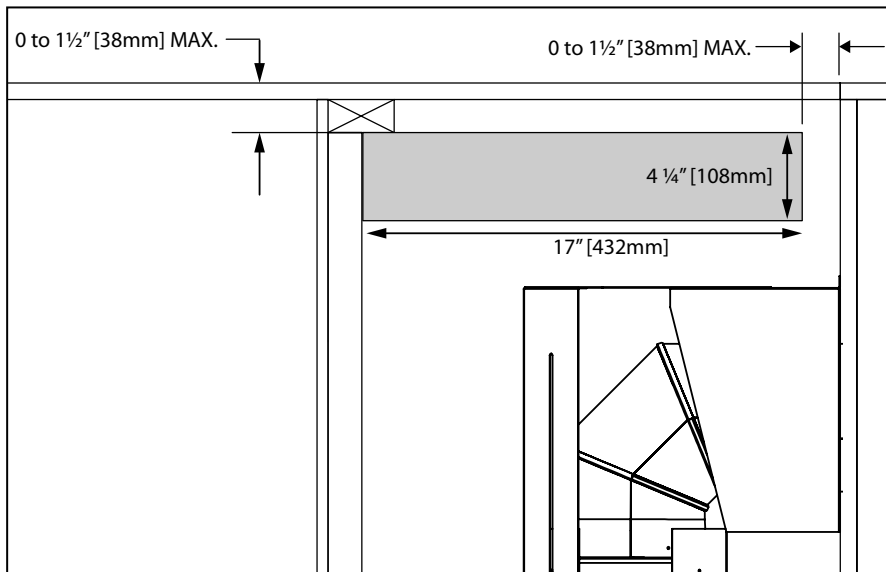


Figure 48: Side Discharge

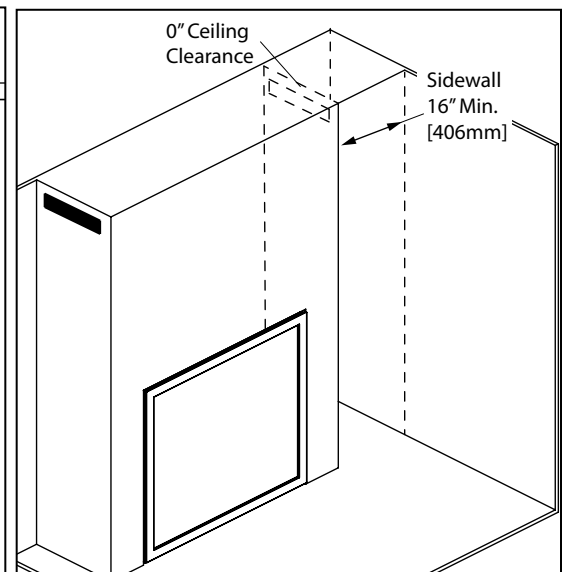


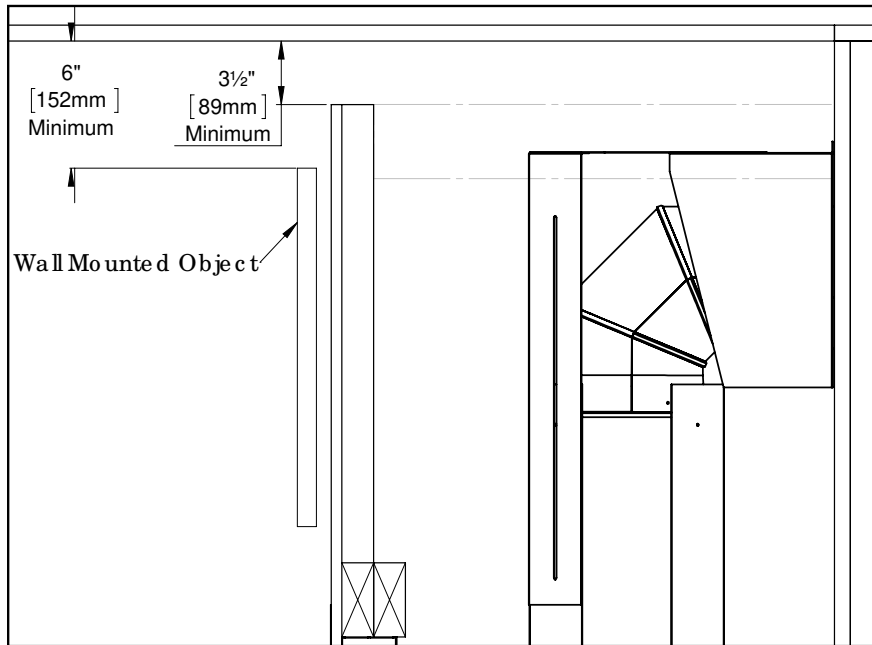
Figure 49: Side Discharge Iso View

# INITIAL INSTALLATION

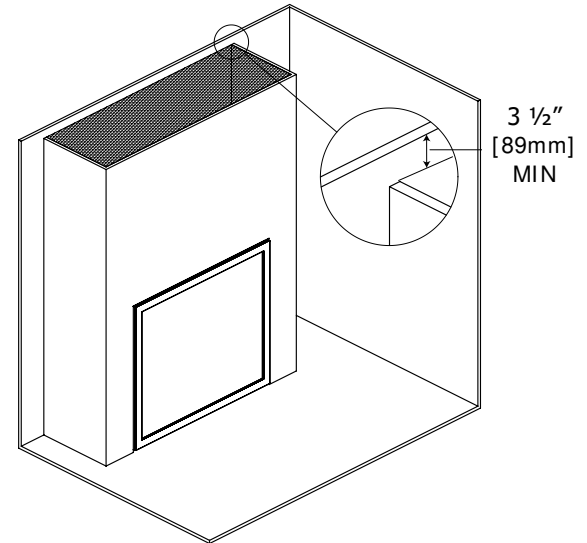
## QUALIFIED INSTALLERS ONLY

**Option 4: Open Chase / Shadow Line (for built-out installations)** - This could be considered the most discreet option when considering the CSS. The chase must be constructed in a way that stops short of the ceiling, leaving it totally vented above. Minimum framing dimensions must be followed when constructing this option and not to deviated from them when using combustible materials.

**Note** - Chase cannot be open to joists or rafters above.



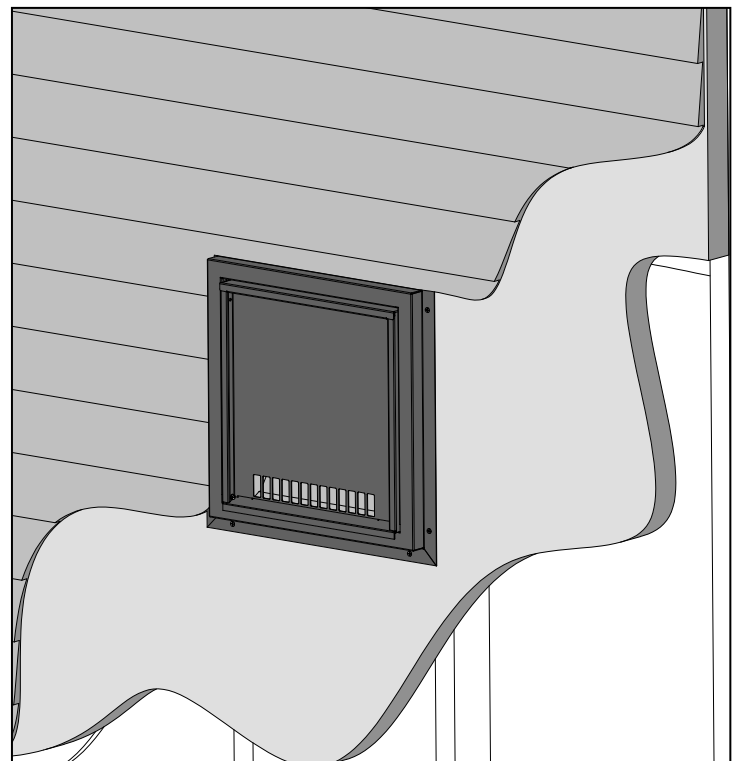
**Figure 50: Open Chase / Shadow Line**



**Figure 51: Open Chase Iso View**

### **Additional Option: Chase Comfort Kit (50-3813)**

- If the CSS system is being used and additional control of the fireplace's heat is desired then the Chase Comfort Kit may be used. The Chase Comfort Kit is a blower motor housing that gets mounted on the same exterior wall as the chase and discharges the heat outside. The CSS system must still have a permitted type of heat discharge (as outlined in this section) but the Comfort Kit blower speed can be adjusted or turned on/off as desired. For more details and installation specifications refer to the 50-3813 Chase Comfort Kit installation manual.



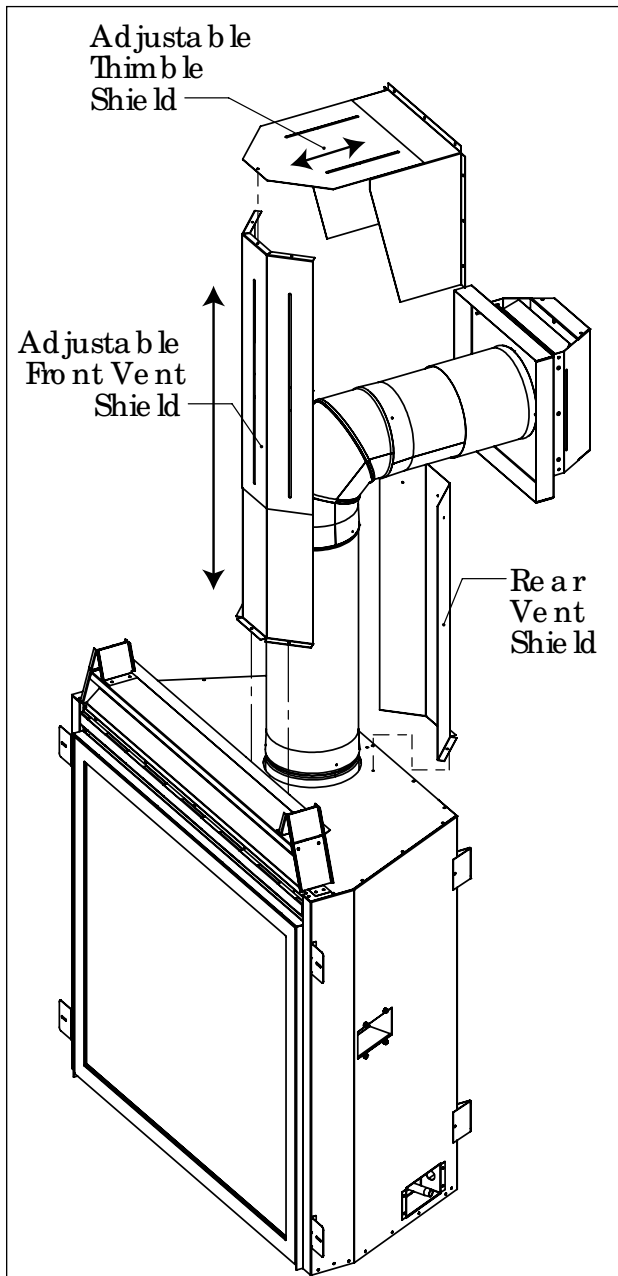
**Figure 52: Chase Comfort Kit**

# INITIAL INSTALLATION

## QUALIFIED INSTALLERS ONLY

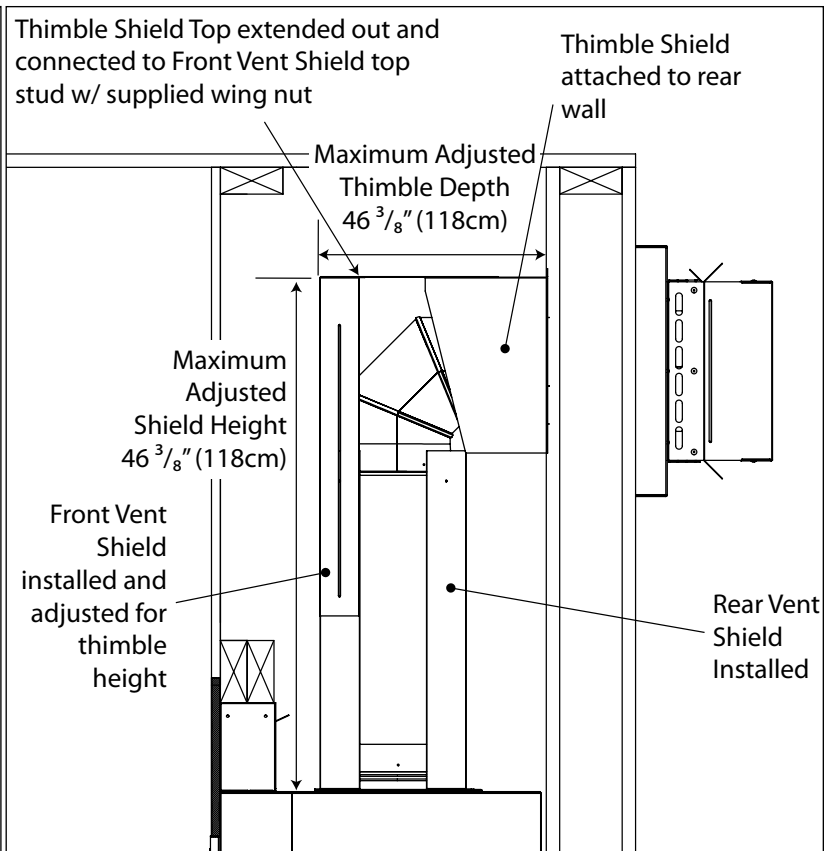
### REQUIRED VENT HEAT SHIELDS:

The RZ41 fireplace is supplied with a set of vent heat shields that are mandatory for all installations.

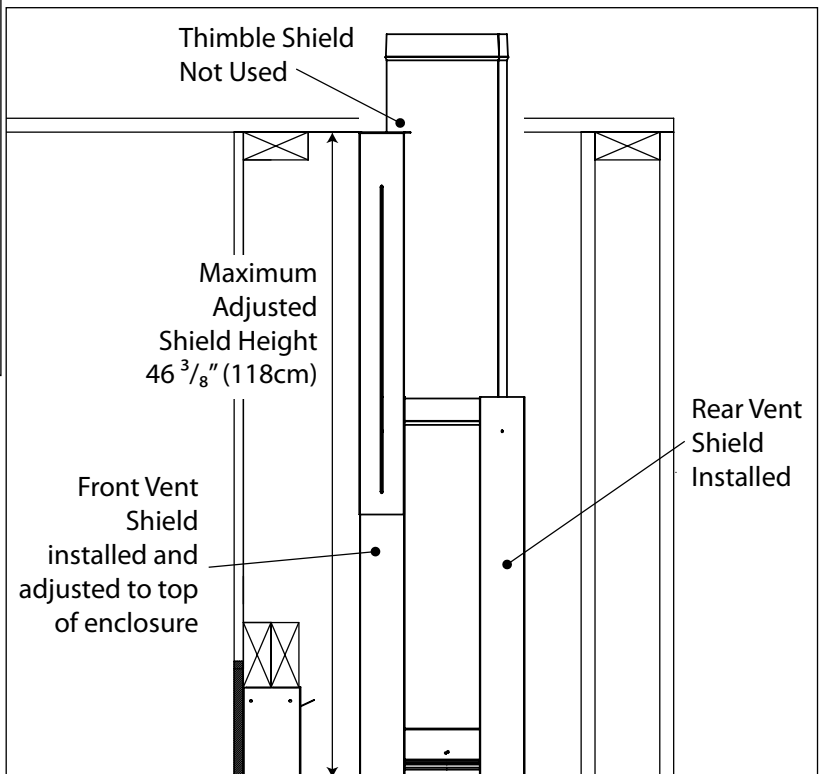


**Figure 53: Supplied Vent Shields**

**Note** - Adjustable Thimble shield supplied with one bend flattened for packaging. Fold second leg of thimble shield down to form an upside down U shape as shown above.



**Figure 54: Vent Shields - Up and Out**



**Figure 55: Vent Shields - Through Ceiling**

# INITIAL INSTALLATION

## QUALIFIED INSTALLERS ONLY

### MINIMUM INSTALLATION:

These are the minimum allowable dimensions required to safely install and operate the fireplace. Plan your entire installation before proceeding.

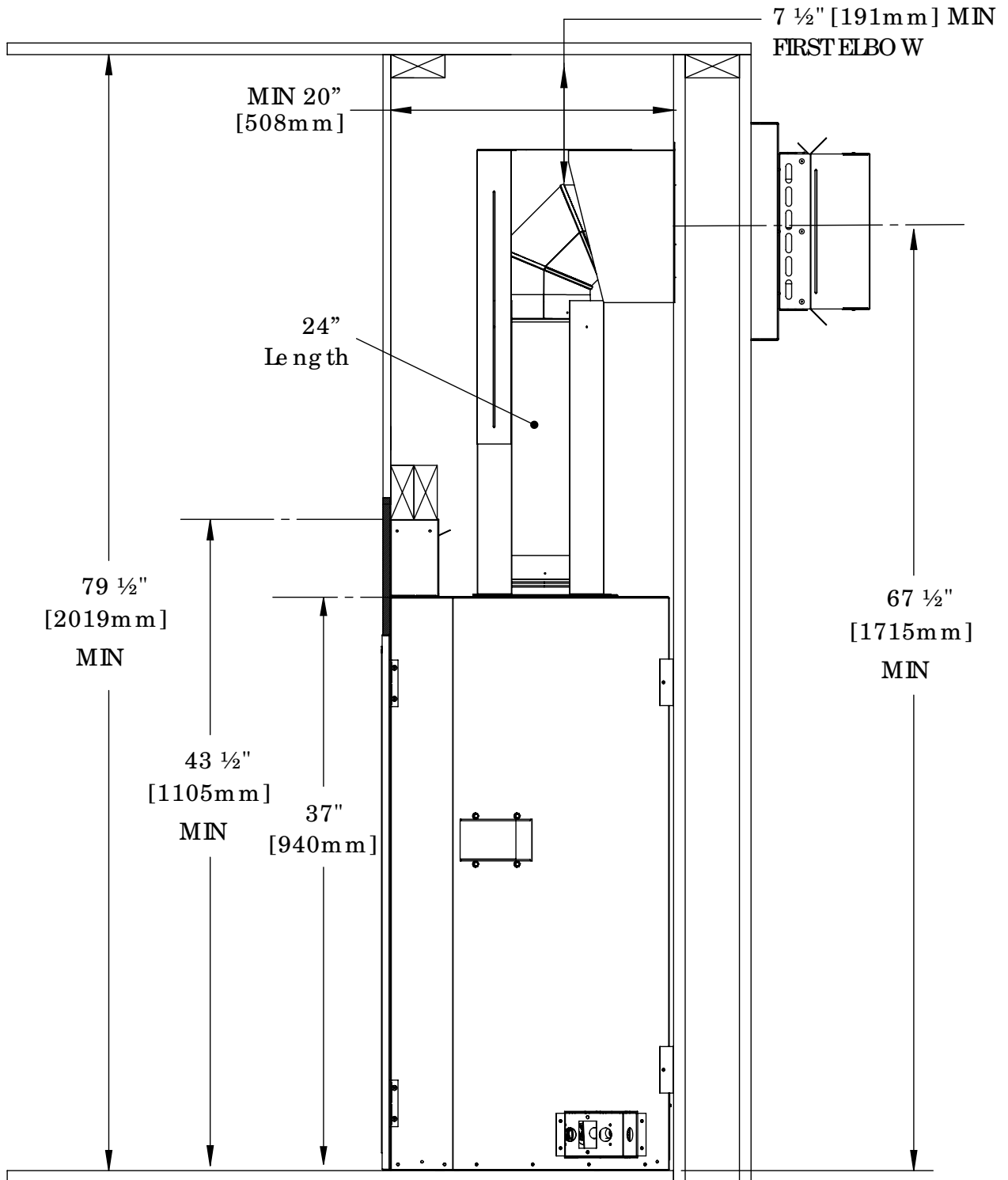


Figure 56: Minimum Installation

# INITIAL INSTALLATION

## QUALIFIED INSTALLERS ONLY

### RECESS INSTALLATION

These are the minimum allowable dimensions required to safely install the fireplace with a recess above. Plan your entire installation before proceeding. The maximum allowable depth for a recess in  $4\frac{1}{4}$ " (108mm) + finishing material thickness covering the front of the fireplace.

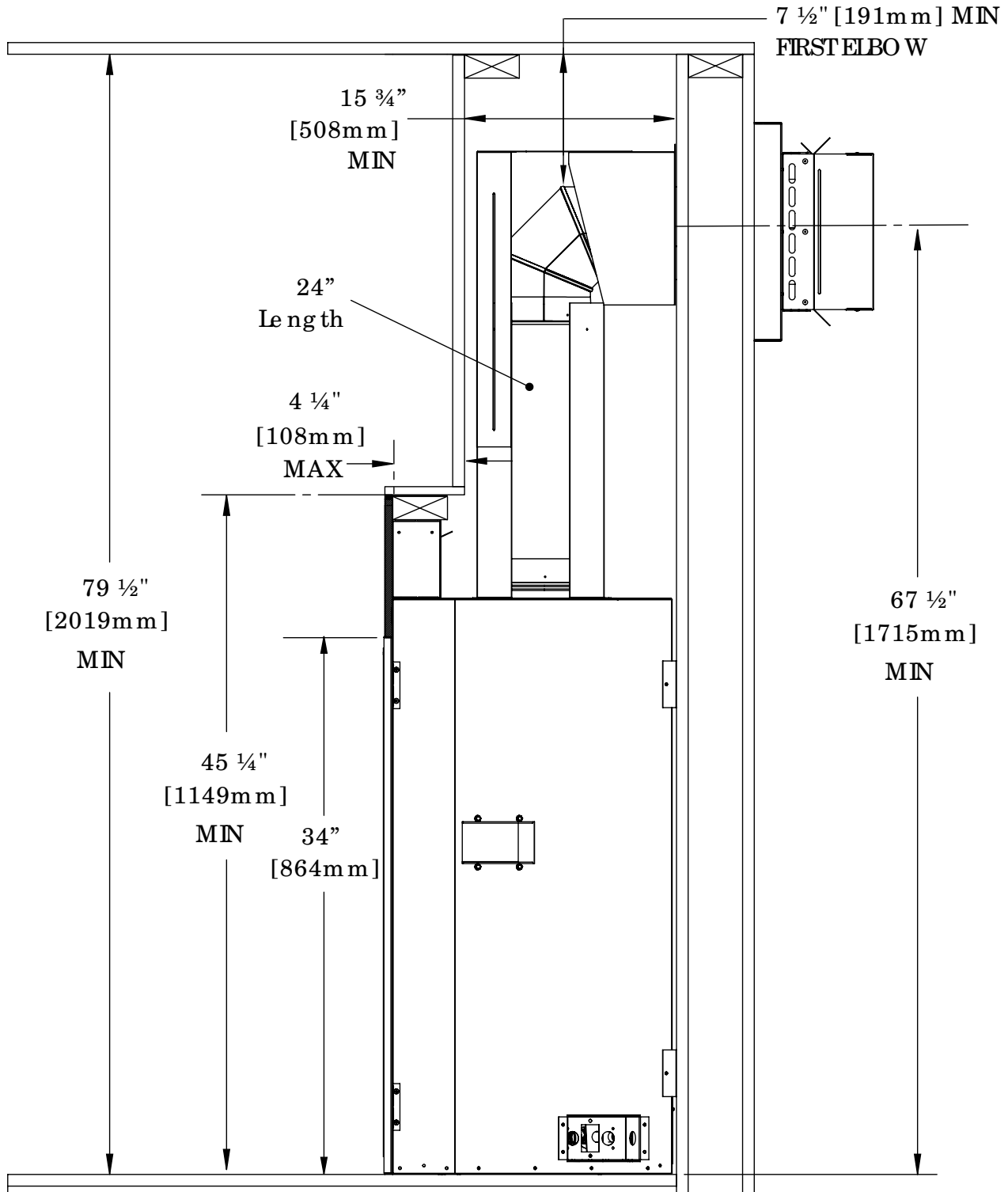


Figure 57: Recess Installation

# INITIAL INSTALLATION

## QUALIFIED INSTALLERS ONLY

### CORNER INSTALLATION:

These are the minimum allowable framing dimensions required to safely operate the fireplace in a corner install. Plan your entire installation before proceeding.

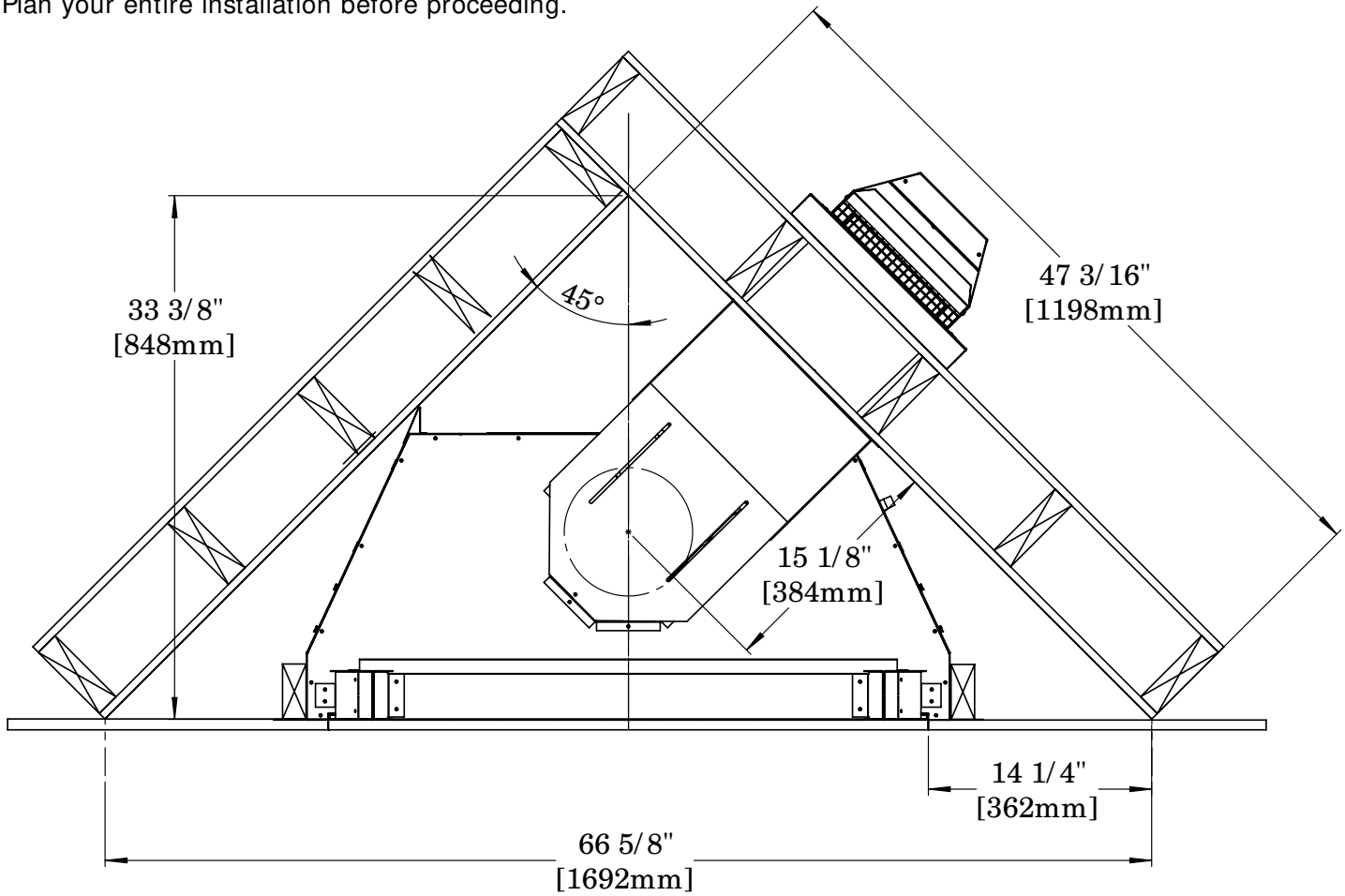


Figure 58: Corner Installation

# INITIAL INSTALLATION

## QUALIFIED INSTALLERS ONLY

### TV INSTALLATION CLEARANCES:

**Use of the Cool Surface System is highly recommended when mounting a TV or delicate artwork above the fireplace.** If the system is not desired, some considerations must be made to ensure above objects are protected from the heat. A mantel, or recess with a mantel will be required for heat protection.

There is no guarantee these guidelines will not harm the longevity of your TV/electronic device. Refer to the manufacturer's specifications to find the maximum allowable operating temperature. Since every home and installation is unique, temperatures must be verified at the time of install to confirm they do not exceed the manufacturer's maximum allowable temperature. Sherwood Industries is not responsible for any damage to a TV or other electronic device mounted directly above the fireplace.

**Mantel Only Installation:** Always maintain minimum clearances (see Figure 59). The total depth of the TV and wall mount will determine the minimum allowable mantel depth and installation height. Use of the Cool Surface System is highly recommended.

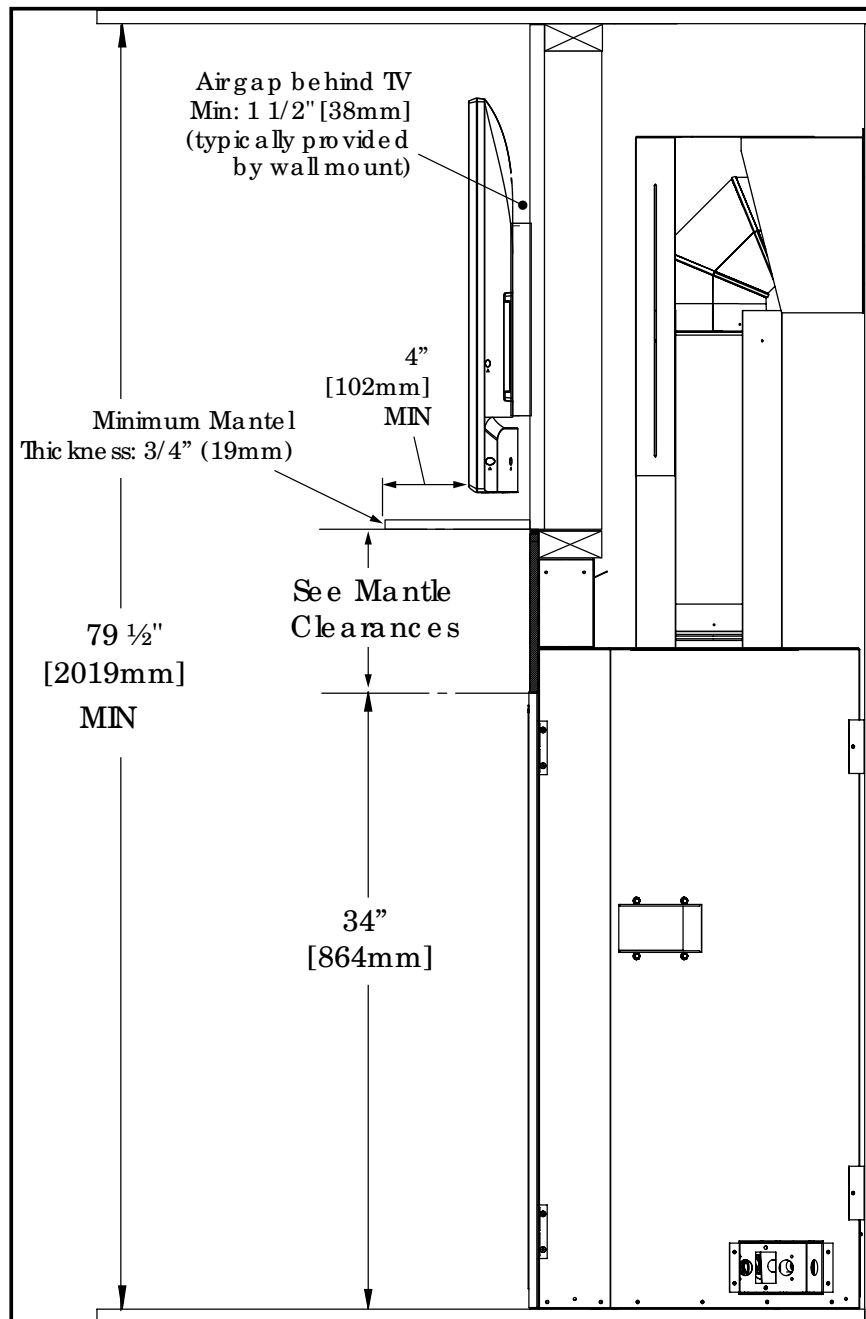


Figure 59: Minimum TV Install w/ Mantel

# INITIAL INSTALLATION

## QUALIFIED INSTALLERS ONLY

**Recess Installation w/ Mantel:** Always maintain minimum clearances (see Figure 60). The total depth of the TV and wall mount as well as the recess depth will determine the minimum required mantel depth. See “INITIAL INSTALLATION - MANTEL CLEARANCES” and “INITIAL INSTALLATION - RECESS INSTALLATION” for more information.

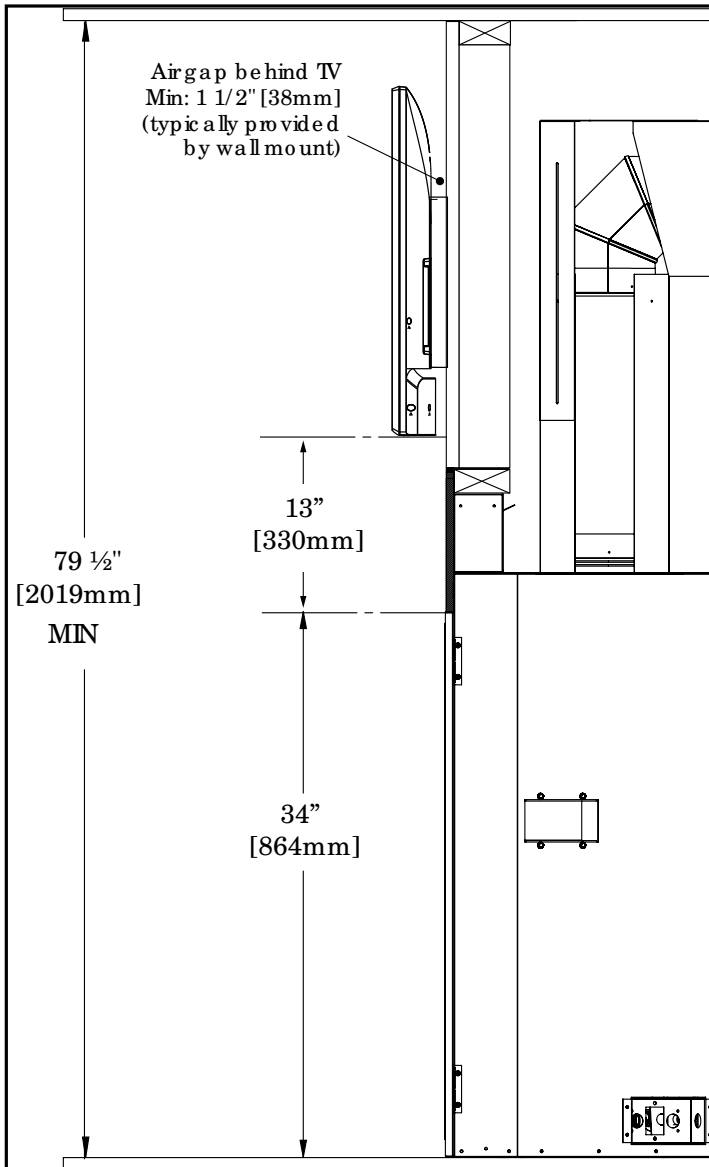


Figure 61: Recess w/ Mantel - TV Installation

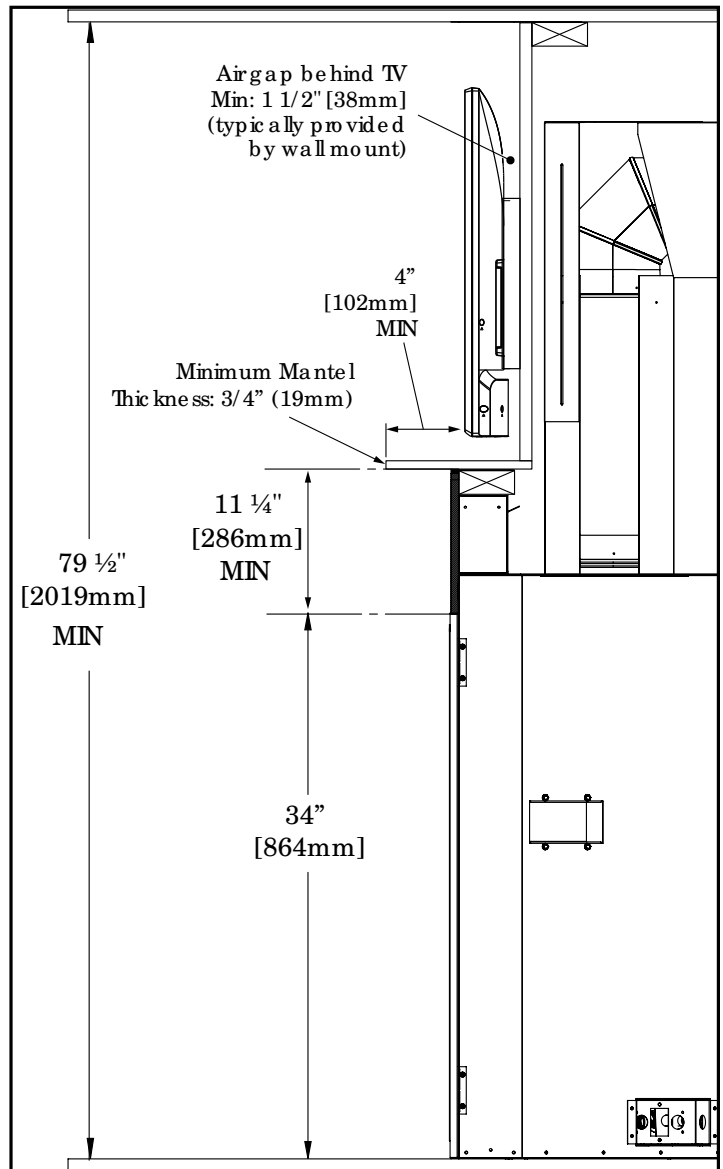


Figure 60: Recess w/ Mantel TV - TV Installation

**No Mantel or Recess with Cool Surface System:** If the cool surface system has been activated with an approved method of heat release (See INITIAL INSTALLATION - COOL SURFACE INSTALL OPTIONS) a TV may be installed **13" above the fireplace** without a recess or mantel (Figure 61). Operating temperatures of the TV still must be verified at the time of install to confirm they do not exceed the manufacturer's maximum allowable temperature.

# INITIAL INSTALLATION

## QUALIFIED INSTALLERS ONLY

### DIRECT VENT:

#### WARNING:

- This gas appliance must be direct vented and can't be connected to a chimney flue serving a separate solid-burning appliances.
- Follow the venting instructions exactly for safe and proper appliance operation.
- Use Mill Pac or high temp RTV silicone for all appliance venting connections.
- Risk of fire, explosion, or asphyxiation if improper venting setup.
- Risk of fire, do not allow loose materials to contact vent pipe.

This appliance uses a 5" (127mm) exhaust / 8" (203mm) air intake vent pipe system. For safe and proper operation of the appliance follow the venting instructions exactly. Deviation from the minimum vertical length will create difficulty in burner start-up and sooting. Allow up to 15 minutes for the flame to stabilize and mature after ignition under extreme vent configurations. It is recommended for vent lengths that pass through unheated spaces (garages, attics, crawl spaces) be insulated to minimize condensation. Use at least three (3) screws at each vent connection. Check periodically that the vents are unrestricted, especially the exterior vent cap.

### THIMBLE & GENERAL VENTING CLEARANCES:

A 1" (25 mm) clearance to combustibles must be maintained around any vertical vent pipe. Around a horizontal vent pipe, the clearance to combustibles should be 3" (76 mm) above and 1" (25 mm) on the sides and bottom. When combustible materials are directly above the first 90° elbow, 4" (102 mm) of clearance is necessary.

Table 4: Vent Pipe Minimum Clearances

	Vertical Pipe to the Side Walls	Horizontal Pipe to the Sides & Bottom	Above First Elbow in Chase	Above Subsequent Elbows	Above Horizontal Vent Pipe	Wall Frame 8" (203mm) or less
Hard Pipe	1" (25mm)	1" (25 mm)	7 1/2" (191 mm)	3" (76 mm)	3" (76 mm)	3" top (76mm)

See certified thimbles in venting section and frame accordingly. A thimble will assure the proper support and spacing requirements for the vent pipe as it passes through the exterior wall.

Installations in Canada require that a wall thimble be used for passing through walls and ceilings. All sealing and vapour barriers must comply with local building codes.

**For installations using a horizontal thimble**, a framed opening of 10 1/2" x 12 1/2" (figure 62) is required to provide an additional 2" top framing clearance. **For installations using a vertical thimble**, a standard 10 1/2" x 10 1/2" framed opening can be used. This appliance also requires that all thimble applications be fully insulated with non-combustible mineral wool (rock wool) as shown below.

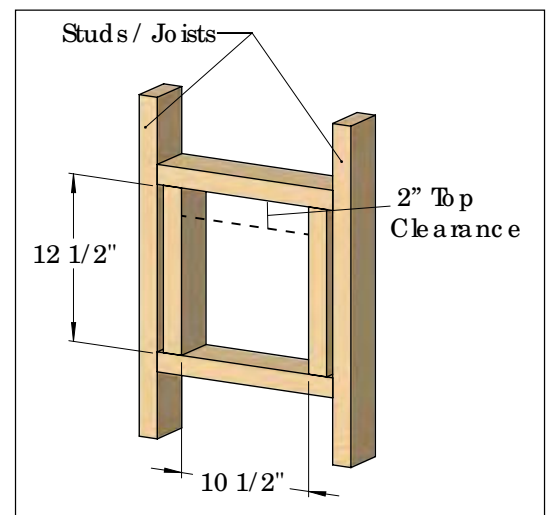


Figure 62: Horizontal Thimble Framing

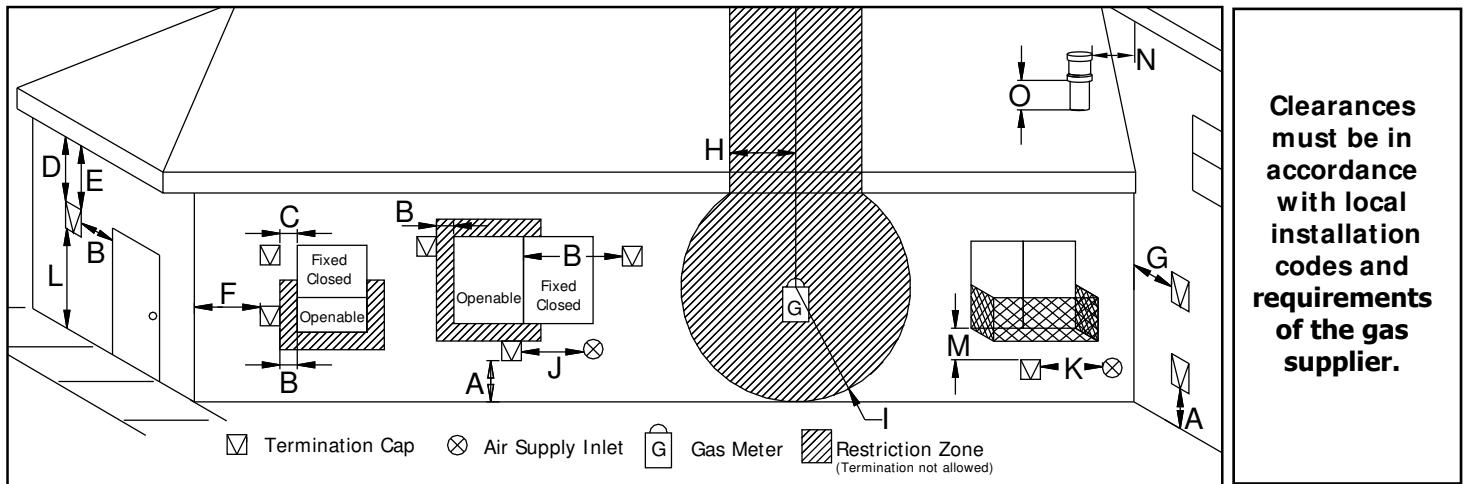


Figure 63: Thimble Insulation

# INITIAL INSTALLATION

## QUALIFIED INSTALLERS ONLY

### VENT TERMINATION RESTRICTIONS:



**Figure 64: Vent Termination Restrictions, refer to Table 5 & Figure 65**

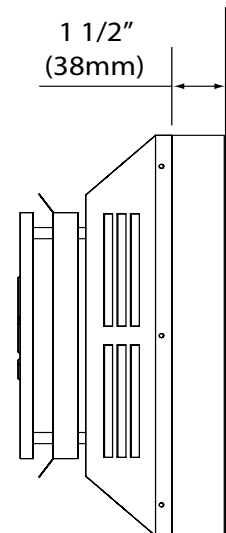
**Table 5: Vent Termination Clearances MINIMUMS**

Letter	Canadian Installation <sup>1</sup>	US Installation <sup>2</sup>	Description
A	12 in (30 cm)		Clearance above grade, verandah, porch, deck, or balcony.
B	12 in (30 cm)		Clearance from window or door that may be opened.
C	12 in (30 cm)*		Clearance from permanently closed window (to prevent condensation).
D	25 1/2 in (65 cm) [From center of vent] *This clearance does not account for vinyl soffits / overhangs. Increased clearance strongly recommended*		Vertical clearance to ventilated soffit located above the terminal, within a horizontal distance of 14 in (36 cm) from center line of terminal.
E			Clearance to unventilated soffit.
F	12 in (30 cm)*		Clearance to outside corner.
G	12 1/2 in (32 cm) [From center of vent]		Clearance to inside corner.
H	3 ft (91 cm) within a height of 15 ft (4.5 m) above the meter/regulator assembly	3 ft (91 cm) within a height of 15 ft (4.5 m) above the meter/regulator assembly*	Clearance to each side of center line extended above meter/regulator assembly.
I	3 ft (91 cm)	3 ft (91 cm)*	Radial clearance around service regulator vent outlet.
J	12 in (30 cm)		Clearance to non-mechanical air supply inlet to building, or the combustion air inlet to any other appliance.
K	6 ft (1.83 m)	3 ft (91 cm) above if within 10 ft (3 m) horizontally	Clearance to mechanical air supply inlet.
L	7 ft (2.13 m) <sup>†</sup>	7 ft (2.13 m) <sup>*†</sup>	Clearance above paved sidewalk or paved driveway located on public property.
M	25 1/2 in (65 cm) <sup>+</sup> [From center of vent]		Clearance under verandah, porch, deck, or balcony.
N	12 in (30 cm)*		Clearance horizontally to any surface (such as an exterior wall) for vertical terminations.
O	12 in (30 cm)		Clearance above roof line for vertical terminations.

<sup>1</sup> In accordance with the current CSA B149.1, Natural Gas and Propane Installation Code.

<sup>2</sup> In accordance with the current ANSI Z223.1 NFPA 54, National Fuel Gas Code.

**NOTE:** Horizontal venting terminals shall not be recessed into walls or siding. Horizontal venting terminals, other than ICC EXCELDirect 5HT, must have a 1 1/2" (38 mm) clearance from the finished exterior wall surface. Use M&G Duravent Part # 58DVA-VSS. This clearance DOES NOT apply to non-cumbersome building finishes such as stone, brick and cement fiber siding i.e. HardiePlank®.



**Figure 65: Termination Clearance**

\* These numbers are only estimates.

<sup>†</sup> A vent shall not terminate directly above a side walk or paved driveway that is located between two single family dwellings and it serves both dwellings.

<sup>+</sup> Permitted only if verandah, porch, deck, or balcony is fully open on a minimum of two sides beneath the floor.

# INITIAL INSTALLATION

## QUALIFIED INSTALLERS ONLY

### APPROVED VENTING PARTS:

This fireplace has been tested and certified for use with the venting brand names listed in Table 6. Refer to Table 7 below for part numbers of commonly used parts for both venting systems. For more venting parts please visit the respective manufacturers' website.

**WARNING: Do not mix parts from different vent manufacturers' systems.**

**EXCEPTION TO WARNING:** This product has been evaluated by Intertek for using a DirectVent Pro starting collar in conjunction with venting brand names listed in Table 6. Use of these systems with the DirectVent Pro starting collar is deemed acceptable and does not affect the Intertek listing of the appliance.

**Table 6: Approved Vent Manufacturers**

Manufacturer	Brand Name	Nominal Sizes
ICC	EXCELDirect	5" x 8"
M&G Dura-Vent	Direct Vent Pro	5" x 8"
Selkirk	DIRECT-TEMP	5" x 8"
Selkirk	AMP DV	5" x 8"
Metal-Fab Inc.	Sure-Seal	5" x 8"

**Table 7: Approved Vent Parts**

M&G Duravent Direct Vent Pro	ICC EXCELDirect	Selkirk DI RECT-TEMP	Amerivent AMV DV	Metal-Fab Sure-Seal DV	Description
58DVA-06	5DL6	5DT-06		5D6	6" pipe length
			5D7		7" pipe length
58DVA-09	5DL9	5DT-09			9" pipe length
58DVA-12	5DL1	5DT-12	5D12	5D12	12" pipe length
58DVA-18		5DT-18		5D18	18" pipe length
58DVA-24	5DL2	5DT-24	5D2	5D24	24" pipe length
58DVA-36	5DL3	5DT-36	5D3	5D36	36" pipe length
58DVA-48	5DL4	5DT-48	5D4	5D48	48" pipe length
58DVA-60					60" pipe length
58DVA-E30	5DE30				30° elbow
58DVA-E45	5DE45	5DT-EL45	5D45L	5D45L	45° elbow
58DVA-E90	5DE90	5DT-EL90	5D90L	5D90A, 5D90L	90° elbow
58DVA-VSS, DVA-BVS	VSS	5DT-VS/VSK	5DHVS, DVSK	5DVS	Vinyl siding standoff/sheild
58DVA-WT3, 58DVA-WTU3	5WT	5DT-WT	5DWT	5DWT, 5DWT11	Wall thimble
58DVA-SC	SQSC, SC	5DT-SC	5DSC	5DSC	Storm collar
58DVA-WFS		5DT-FS		5DFSH	Wall Fire stop
58DVA-FS	5CS	5DT-FS	5DFSP	5DFS, 5DSPFS	Ceiling Fire stop
58DVA-IS	5AS	5DT-AIS	5DAIS12, AIS36	5DIS	Attic Insulation Shield
58DVA-WS	5WS	5DT-WS/B	5DWS	5DWS	Wall strap/support/band
58DVA-VCH	5SVT	5DT-VT	5DVC	5DVT	High wind vertical termination
58DVA-HC	5HT	5DT-HC	5DHCS	5DHT	High wind horizontal termination*
46DVA-WG	HTS		4DHWS	8DVTS	Wind / Heat Shield
				5DAL	3" to 10" pipe, adjustable
58DVA-17TA					11" to 17" pipe, adjustable
58DVA-24TA					17" to 24" pipe, adjustable
	5DLA30				16.5" to 29" pipe , adjustable
	5DLS1				1 7/8" to 9" slip length pipe
	5DLS2				1 7/8" to 21" slip length pipe
58DVA-F6	6EFA	5DT-AF6	5DF	5DF	Flashing, 0/12 to 6/12 roof pitch
58DVA-F12	6EFB	5DT-AF12	5DF12	5DF-12	Flashing, 7/12 to 12/12 roof pitch
58DVA-FF	6EF			5DFT	Flat Roof Flashings
58DVA-CFK	4MF				Masonry Flashing

\*ICC RHT Termination not permitted for use

\*M&G Sconce Termination not permitted for use

# INITIAL INSTALLATION

## QUALIFIED INSTALLERS ONLY

### PERMITTED VENTING CONFIGURATIONS:

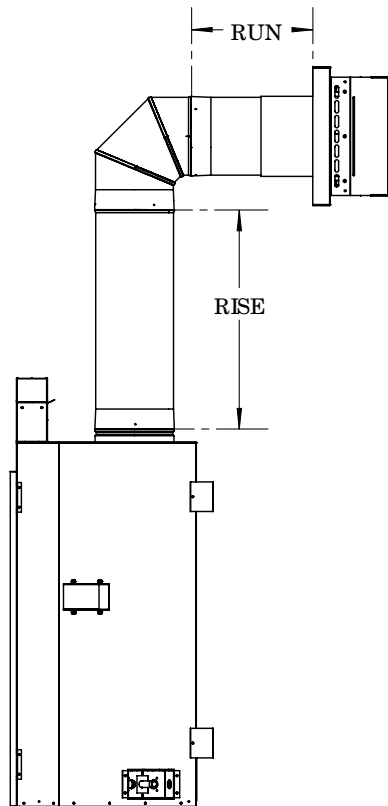
The following tables and charts in this section outline the permitted range of venting configurations using either a vertical or horizontal termination. Any venting layout that remains within the shaded area on the following charts is acceptable. Having the fewest number of elbows is ideal as they restrict air movement. **The total length of horizontal vent pipe can not exceed 22 feet (6.7m) and the total vertical vent length can not exceed 40ft (12.2m).** Any combination of rise and run can be used as long as it lays within the shaded area. A total of three (3) 90° elbows or six (6) 45° elbows can also be used unless otherwise noted in the tables below. In addition to what is shown, if a 90° elbow is used in the horizontal plane, 3 feet (91.4cm) must be subtracted from the allowable horizontal run (for each 45° elbow, 1½ feet (45.7cm) must be subtracted).

**Restrictor Setting:** Find the point on the graph where your vent configuration will terminate. Remember to consider elbows in the HORIZONTAL plane account for horizontal distance as stated above. Use the corresponding exhaust restrictor setting indicated on the chart. See the following section in this manual for restrictor details. Your climate, altitude and installation may alter what restrictor is required for your particular application.

**Table 8: Horizontal Venting (NG/LP)**

Minimum Rise (ft)	Maximum Run (ft)	Number of Vertical 90° Elbows
2	2	1
3	8*	1
4	12	1
20	22	3

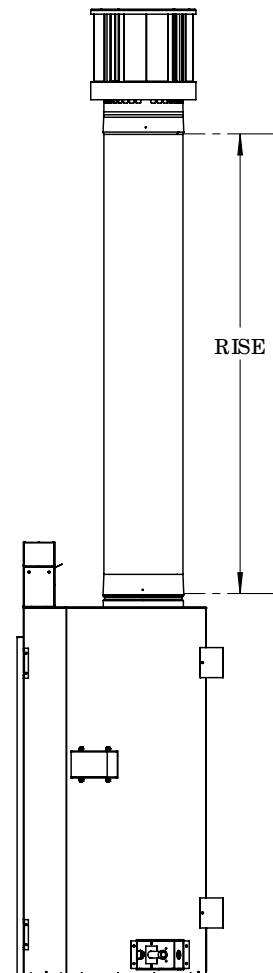
\* Runs longer than 8ft require 4ft initial minimum rise



**Figure 66: Horizontal Venting**

**Table 9: Vertical Venting (NG/LP)**

Minimum Rise (ft)	Maximum Rise (ft)
4	40
<b>Maximum Run @ Maximum Rise (ft)</b>	
6 (with 2 vertical 90° elbows)	



**Figure 67: Vertical Venting**

# INITIAL INSTALLATION

QUALIFIED INSTALLERS ONLY

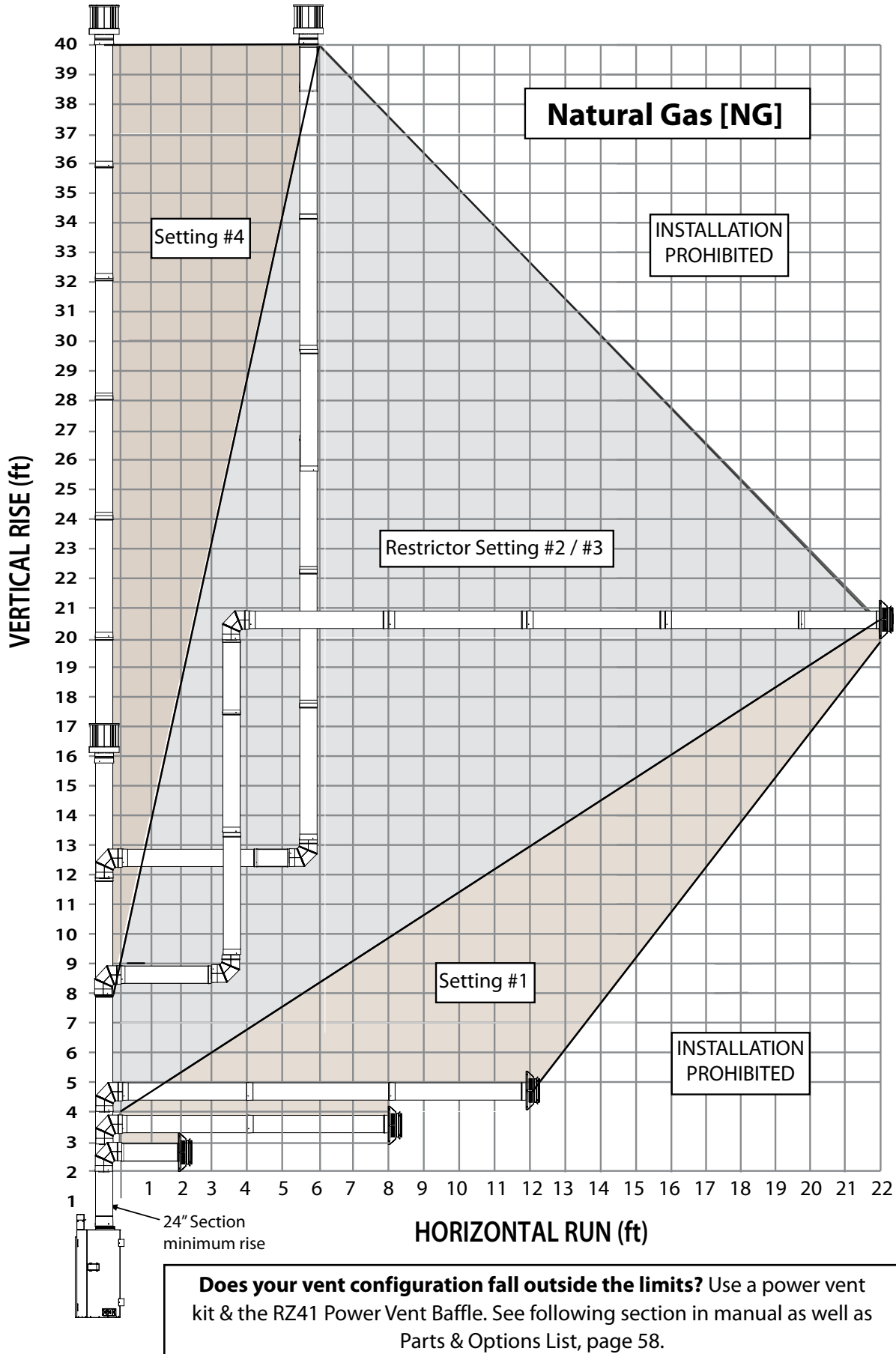


Figure 68: Natural Gas Vent Graph

# INITIAL INSTALLATION

QUALIFIED INSTALLERS ONLY

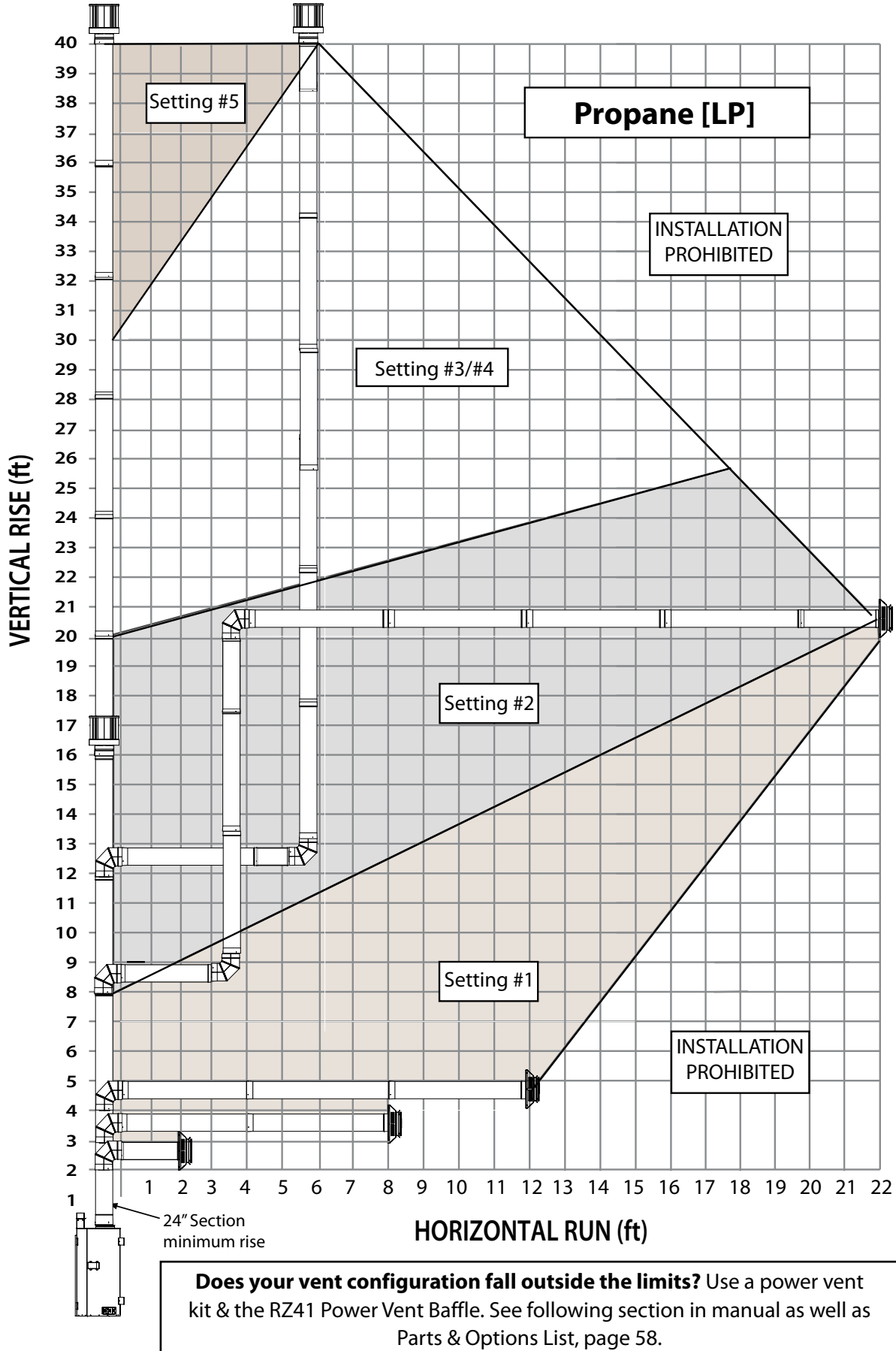


Figure 69: LP Vent Graph

# INITIAL INSTALLATION

## QUALIFIED INSTALLERS ONLY

### POWER VENT BAFFLE (50-4642):

When power venting the RZ41 fireplace is required/desired, the existing baffle must be replaced with the 50-4642 RZ41 power vent baffle. The power vent baffle is supplied separately and not supplied with the fireplace, contact your local Enviro dealer for more information.

**IMPORTANT** - The power vent baffle **CANNOT BE USED** when naturally venting (non-powered) the RZ41.

1. Remove the firebox liners as outlined in the FIREBOX LINER REMOVAL / INSTALLATION section of this manual.
2. Using a Torx T20 screwdriver remove the front four (4) screws from the top of the firebox.
3. Remove the existing baffle by lifting it off the two (2) rear firebox screws.
4. Install the new power vent baffle re-using the screws removed screws (Figure 70).
5. Re-install the firebox liners and remainder of the removed firebox parts.

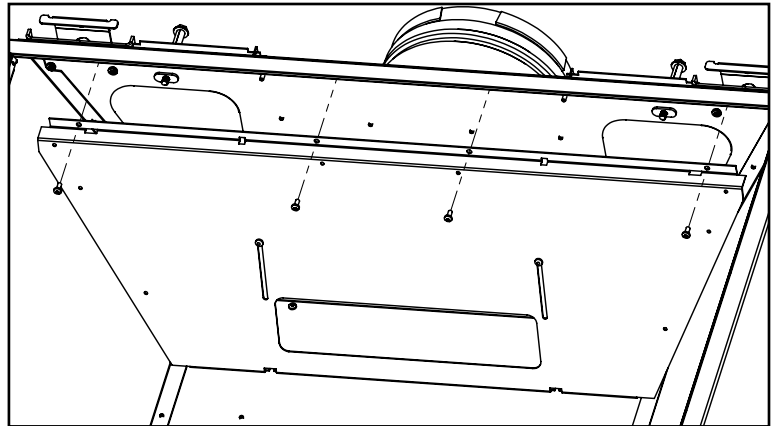


Figure 70: RZ41 Baffle Removal / Installation

### EXHAUST RESTRICTOR SETTING:

**WARNING: Improperly set restrictor setting can cause overheating issues which can lead to building fire.**

It may be necessary to adjust the exhaust restrictor in order to control combustion quality and flame appearance. There are six different restrictor settings.

Determine what restrictor setting you require using the vent graphs in the PERMITTED VENTING CONFIGURATIONS section of this manual. The restrictor is set to 1 when the flat edge of the dial is vertical (see Figure 71). Rotate the dial counter-clockwise to increase the restriction level successively until the appropriate setting is achieved. When the flat edge is horizontal the restrictor level is at its maximum (see Figure 71). The proper setting is crucial for an efficient burn and best possible flame appearance.

It may be necessary to deviate from the recommended setting as different altitudes and climates can vary the operation of the fireplace. With LP fueled fireplaces, it is always a good idea to offer slightly less restriction for higher altitudes to reduce the risk of sooting over an extended period.

1. Remove surround to gain access to restrictor control.
2. Use a 7/16 socket with long extension to adjust the restrictor dial according to the vent graph.
3. Allow unit to warm up sufficiently and make adjustment as needed.
4. Allow unit to cool down and reinstall surround.

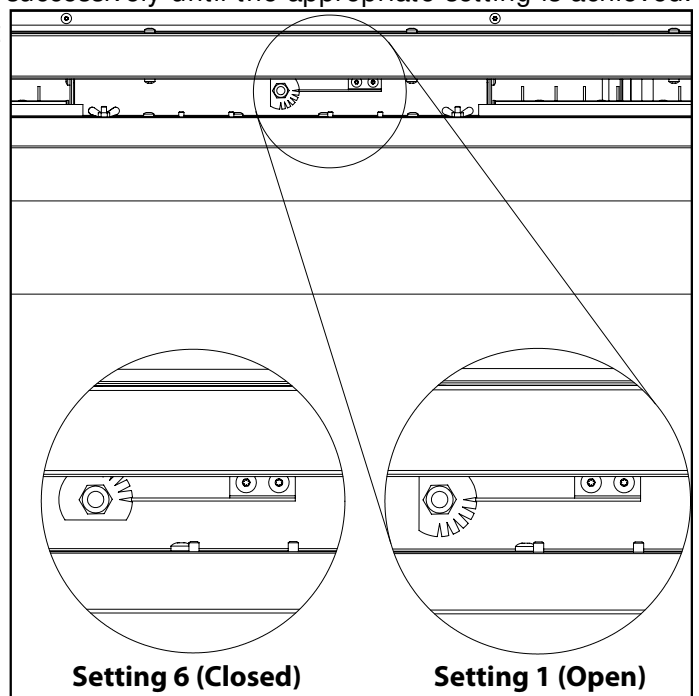


Figure 71: Restrictor Setting Positions

# INITIAL INSTALLATION

## QUALIFIED INSTALLERS ONLY

### HORIZONTAL TERMINATION:

1. A minimum of 24" vertical rise before an elbow is required when horizontally terminating with an approved venting cap.
2. Horizontal pipes must not be level. For every 12" (305 mm) of horizontal travel there should be at least ¼" (6.4 mm) of vertical rise. Never allow the vent to run downward, as this could cause high temperatures or even present the possibility of a fire.

3. The exterior of the horizontal vent termination must not be blocked or obstructed.
4. If the vent termination is not being attached to wood, the four wood screws provided should be replaced with material appropriate fasteners.
5. For buildings with vinyl siding, a vinyl standoff is required between the vent cap and the exterior wall. Attach the vinyl siding standoff to the horizontal termination. Note that the termination screws onto the flat portion of the standoff which provides an air space between the wall and the vent termination. The air gap prevents excessive heat from possibly melting the vinyl siding.
6. Horizontal pipes must be supported every 3' (914 mm). Plumber's "all round" strap will suffice.

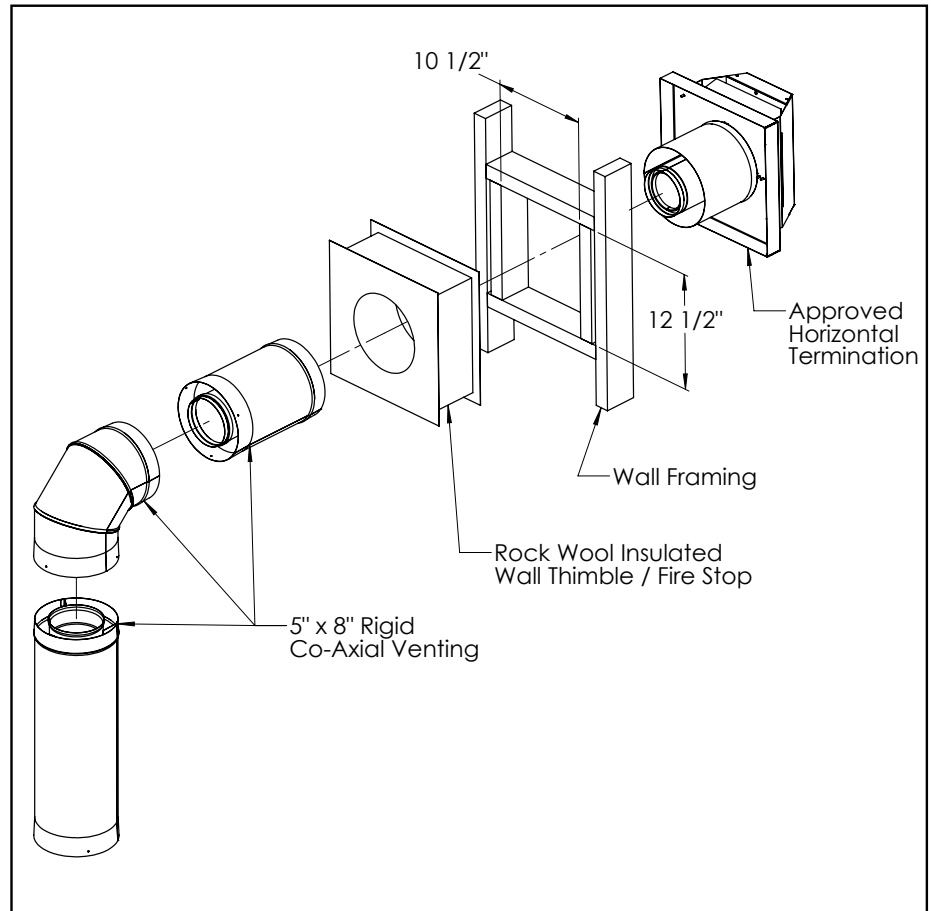


Figure 72: Horizontal Vent Termination

7. Ensure venting clearances are maintained, see page 38 for details.

- Step 1.** Set the fireplace in the desired location. Check to determine if wall studs will be in the way when the venting system is attached. If this is the case, the location of the fireplace may have to be adjusted or the venting may have to be offset.
- Step 2.** Many direct vent pipe sections are designed with special twist-lock connections. Dry fit the desired combination of pipe and elbows to the fireplace.
- Step 3.** With the pipe in the correct position and attached to the fireplace, mark the wall for a hole with the specified wall thimble dimensions. Cut and frame the hole in the exterior wall where the vent will be terminated. If the wall being penetrated is made of a non-combustible material (i.e. masonry or concrete) a minimum 8 1/2" (216mm) hole is acceptable.

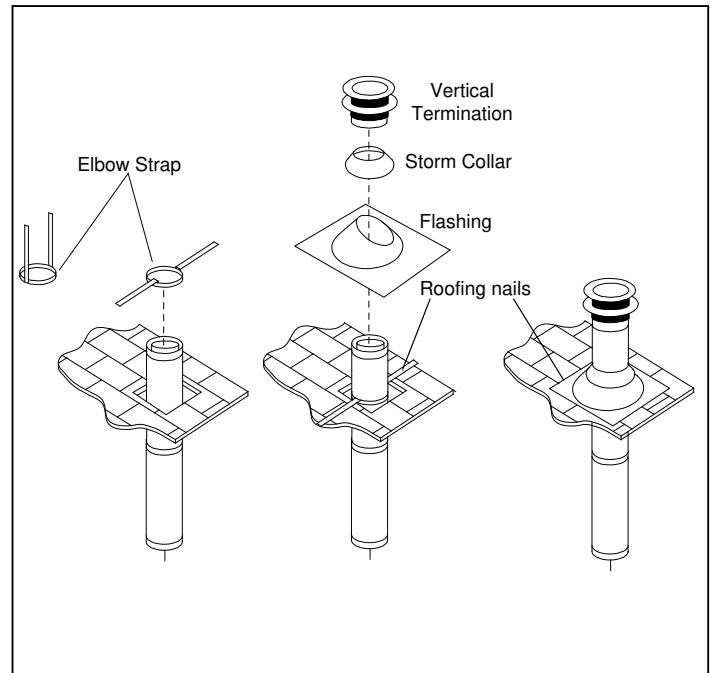
# INITIAL INSTALLATION

## QUALIFIED INSTALLERS ONLY

- Step 4.** The vent pipe must extend into the vent cap at least 1¼ ” (320 mm). Secure the connection between the vent cap and the pipe by attaching the two (2) sheet metal straps, which extend from the vent cap assembly to the outer wall of the vent pipe. Bend any remaining portion of the strap back towards the vent cap.
- Step 5.** Position the horizontal vent termination in the center of the thimble and attach to the exterior wall with the four screws provided. The arrow on the vent termination must be pointing up. Run a bead of high-temp silicone around the edges of the vent cap to make a seal with the wall. Ensure the proper clearances to combustibles have been maintained.

### VERTICAL TERMINATION:

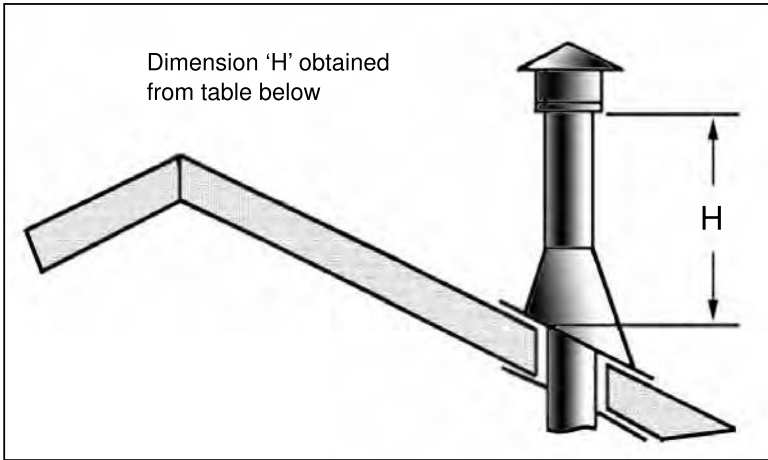
- Step 1.** Refer to page 38 of this manual for required clearances to combustibles when passing through ceilings, walls, roofs, enclosures, attic rafters, or other nearby combustible surfaces. Do not pack air spaces with insulation.
- Step 2.** Set the fireplace in the desired location. Drop a plumb bob down from the ceiling to the fireplace flue exit and mark the location where the vent will penetrate the ceiling. Drill a small hole at this point. Next, drop a plumb bob from the roof to the hole and mark the spot where the vent will penetrate the roof. Determine if ceiling joists, roof rafters, or other framing will obstruct the venting system. Relocate the fireplace or offset the venting to avoid cutting load bearing members.
- Step 3.** To determine the length of pipe required, measure room height, ceiling thickness, and vertical rise in an attic or second story. Firestops are required at each floor level beyond the first floor ceiling support/wall thimble cover or cathedral ceiling support box. If an offset is required to avoid obstructions, use a pair of 45 degree elbows. For proper support, use elbow straps with offsets. Use wall straps for long vertical runs. Attic insulation shield is required in attic.
- Step 4.** Measure roof pitch. Select the proper flashing and storm collar and determine the height above the roof (figure 74 and Table 10). A non-corrosive pipe material must be used for all exterior pipe lengths. Seal nail heads with silicone.



**Figure 73: Vertical Vent Termination**

# INITIAL INSTALLATION

## QUALIFIED INSTALLERS ONLY



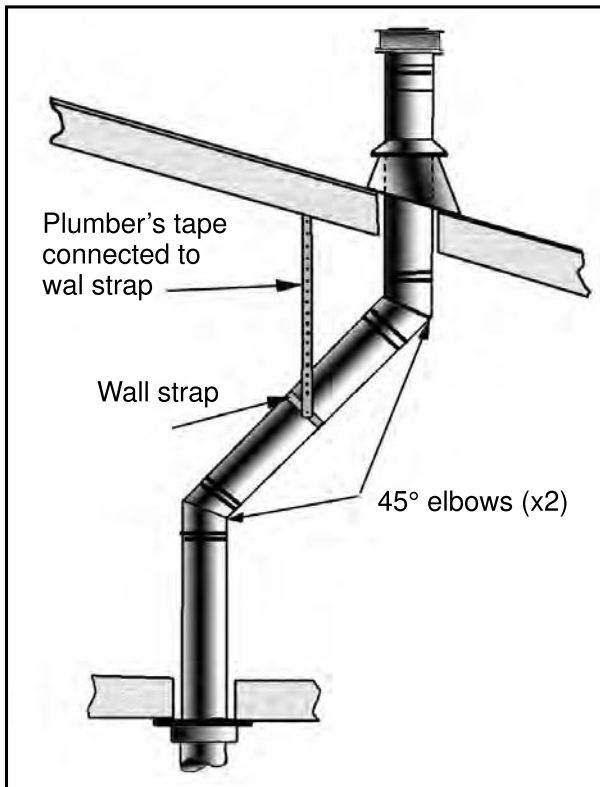
**Figure 74: Height of Vertical Termination; Reference Table 10**

**Table 10: Minimum 'H' for Figure 70.**

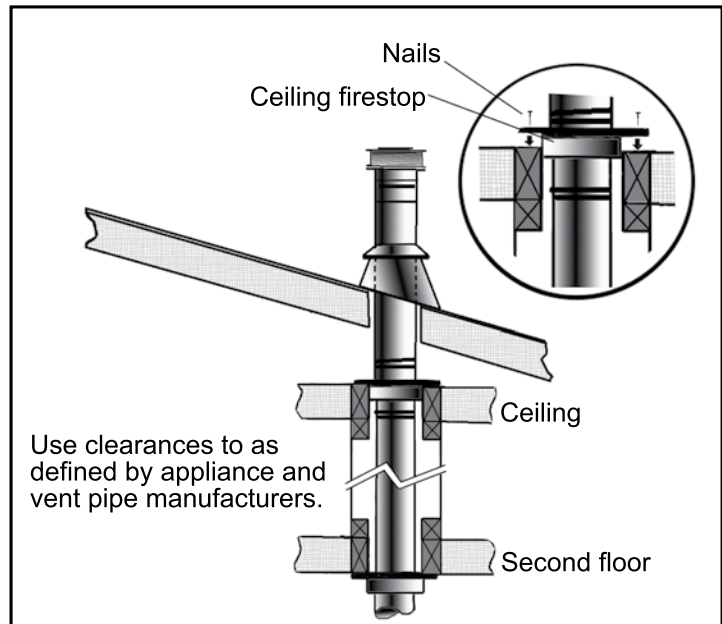
Roof Pitch	Minimum Height (H)	
	Feet	Meters
Flat to 7/12	1	0.3
Over 7/12 to 8/12	1.5	0.46
Over 8/12 to 9/12	2	0.61
Over 9/12 to 10/12	2.5	0.76
Over 10/12 to 11/12	3.25	0.99
Over 11/12 to 12/12	4	1.22
Over 12/12 to 14/12	5	1.52
Over 14/12 to 16/12	6	1.83
Over 16/12 to 18/12	7	2.13
Over 18/12 to 20/12	7.5	2.29
Over 20/12 to 21/12	8	2.44

### NOTES:

1. If an offset is necessary in the attic to avoid obstructions, it is important to support the vent pipe every **3' (914 mm)** using wall straps to avoid excessive stress on the elbows.
2. Use 45° degree elbows instead of 90° degree elbows when ever possible. The 45° degree elbow offers less restriction to the flow of flue gases and intake air.



**Figure 75: Multi-Story Vent Pipe Installation**



**Figure 76: Use of Wall Straps.**

# INITIAL INSTALLATION

## QUALIFIED INSTALLERS ONLY

### GAS LINE CONNECTION AND TESTING:

**WARNING:** Only persons licensed to work with gas piping may make the necessary gas connections to this appliance.

### GAS LINE CONNECTION

- This fireplace is equipped with a certified flexible pipe located on the right side of the unit terminating in a 3/8" Male NPT fitting. Consult your local authorities codes or the CAN/CGA B 149 (1 or 2) installation code in Canada, or in the USA gas installations follow either local codes or the current edition of the National Fuel Gas Code ANSI Z223.1.
- The fireplace and its shutoff valve must be disconnected from the gas supply piping system during any pressure testing where the pressure exceeds 1/2 PSIG (3.45 KPa) or damage will occur to the valve.
- The fireplace must be isolated from the gas supply piping system by closing its individual manual shutoff valve during any pressure testing of the gas supply piping system at test pressures equal to or less than 1/2 PSIG (3.45 KPa).

**Always check for gas leaks with a soap and water solution after completing the required pressure test.**

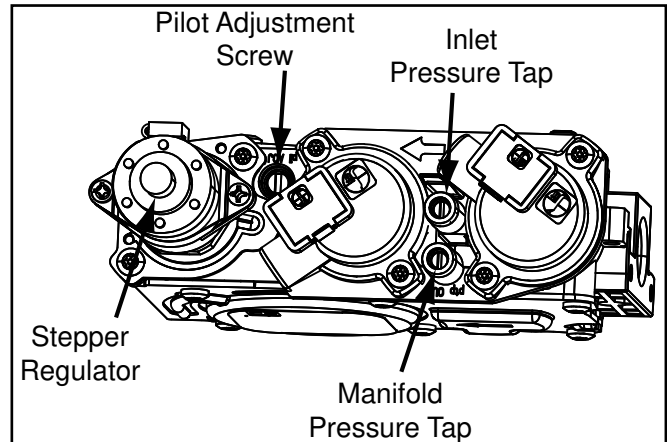


Figure 77: Fully Labeled Gas Valve.

### TO TEST VALVE PRESSURES

The pressure taps are located on the top right of the valve shown in Figure 77.

- Turn set screw 1 turn counter clockwise to loosen,
- Place 5/16" (8 mm) I.D. hose over pressure tap system.
- Check pressures using a manometer.
- When finished, release pressure, remove hose & tighten set screw.

Table 11: Pressure and BTU Information.

	Natural Gas	Propane
<b>Main Orifice</b>	# 49 (Left & Right) / # 55 (Center)	# 57 (Left & Right) / # 59 (Center)
<b>Manifold Pressure</b>	3.6" W.C. (0.89 KPa)	10.0" W.C. (2.49 KPa)
<b>Min. Manifold Pressure</b>	1.6" W.C. (0.39 KPa)	6.4" W.C. (1.59 KPa)
<b>Max Supply Pressure</b>	7.0" W.C. (1.74 KPa)	11.0" W.C. (2.74 KPa)
<b>Min. Supply Pressure</b>	5.0" W.C. (1.24 KPa)	10.6" W.C. (2.64 KPa)
<b>Max BTU/hr Input</b>	40,000 BTU/hr (11.7 KW)	38,000 BTU/hr (11.1 KW)
<b>Min. BTU/hr Input</b>	26,000 BTU/hr (7.6 KW)	30,000 BTU/hr (8.8 KW)

**NEVER USE AN OPEN FLAME FOR LEAK TESTING.**

# INITIAL INSTALLATION

## QUALIFIED INSTALLERS ONLY

### ELECTRICAL REQUIREMENTS:

**WARNING:** The fireplace must be electrically connected and grounded in accordance with local codes or, in the absence of local codes, with the current CSA C22.1 Canadian Electrical Code Part 1, Safety Standards For Electrical Installations, or The National Electrical Code ANSI / NFPA 70 in the US.

**WARNING:** Disconnect electrical power supply before working on receptacle wiring.

**CAUTION:** When servicing controls, label all wires prior to disconnection. Wiring errors can cause improper and dangerous operation. Verify proper operation after servicing. If any of the original wire supplied with the appliance must be replaced, it must be replaced with 18 AWG wire with a temperature rating of 105°C.

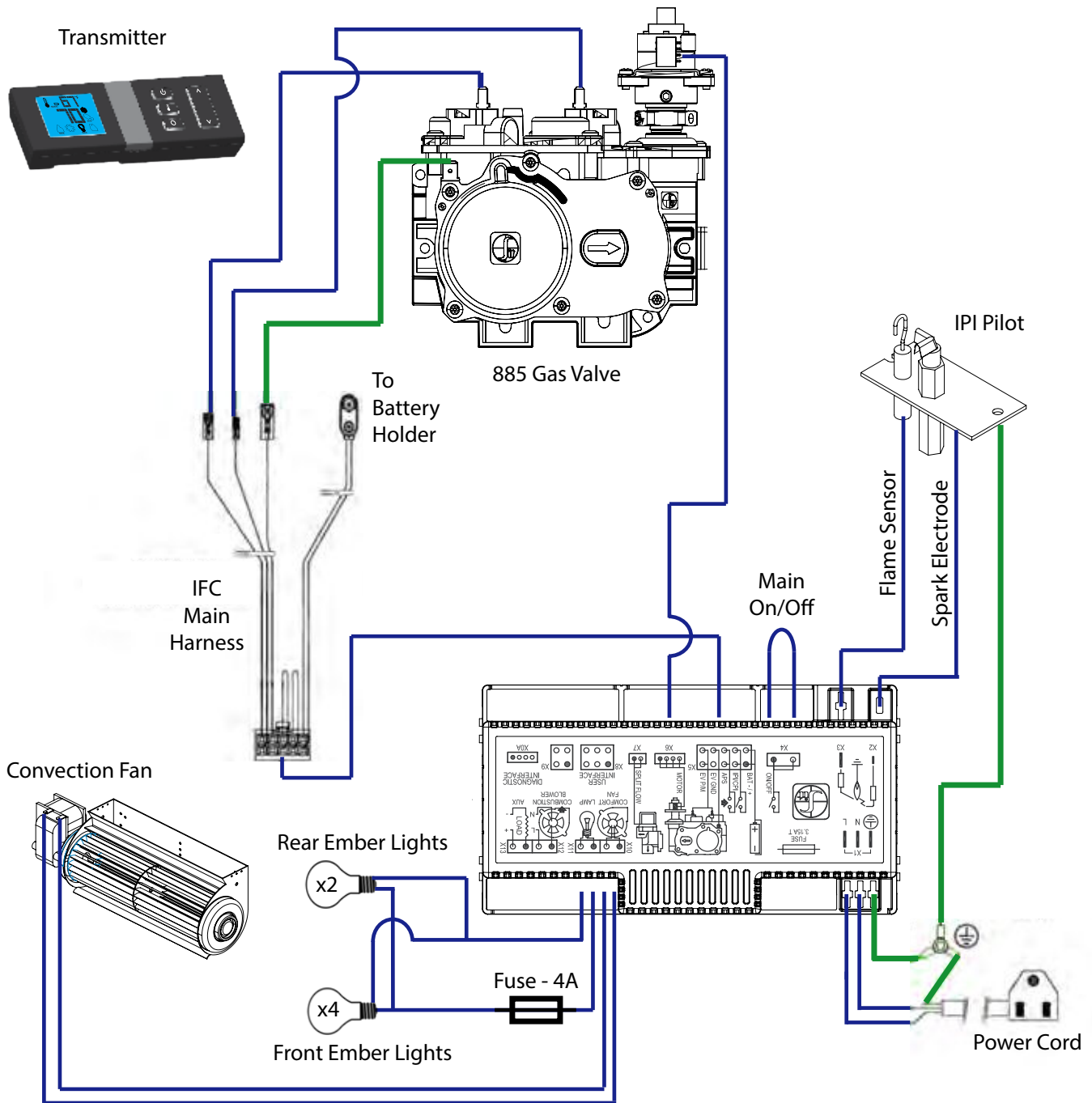


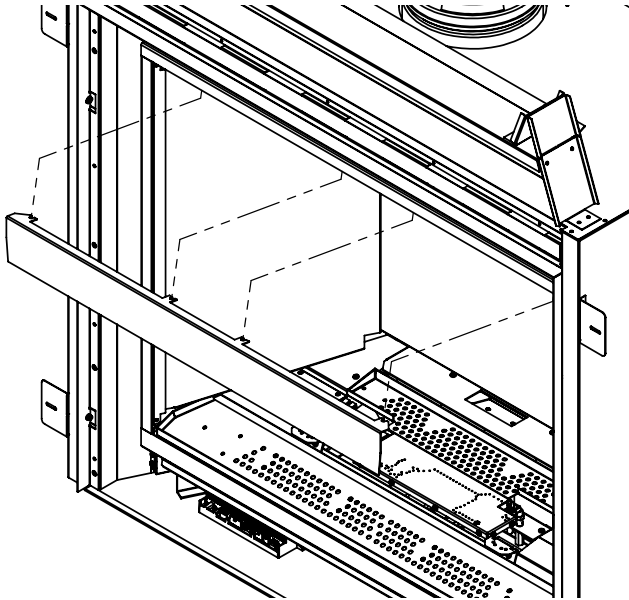
Figure 78: Proflame 2 Wiring Diagram

# SECONDARY INSTALLATION

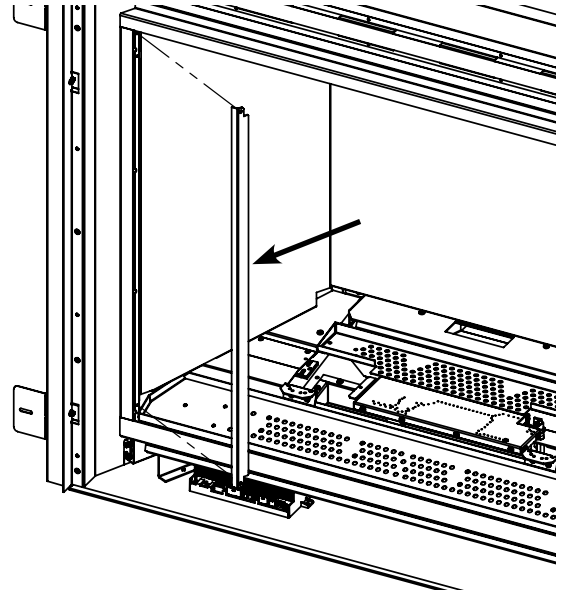
## FIREBOX LINER REMOVAL/INSTALLATION:

The RZ41 fireplace is supplied from the factory with painted steel liners installed. If a different liner option is desired i.e. Herringbone, Brick etc. the steel liners will need to be removed first. A Torx T20 screwdriver / driver bit is required for all fasteners

1. Remove the surround, glass door, log set (if installed), elevated burners and log grate. The burner pan does not need to be removed for liner removal/installation. See ANNUAL MAINTENANCE, MAINTENANCE AND SERVICE sections of this manual.
2. Remove the light deflector at the top front of the firebox by loosening the four (4) retaining screws. The light deflector is slotted. (see Figure 79).
3. Next, remove the liner front edge retainers. There are two (2) screws per side holding the retainers in place.

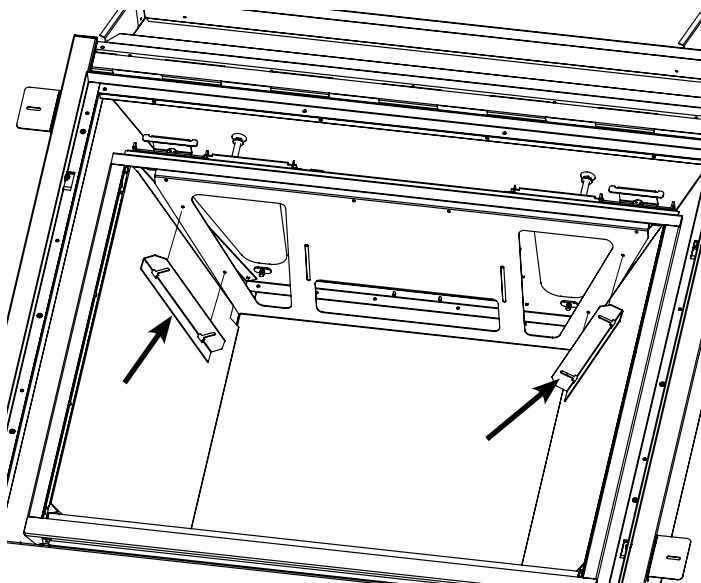


**Figure 79: Light Deflector Removal**

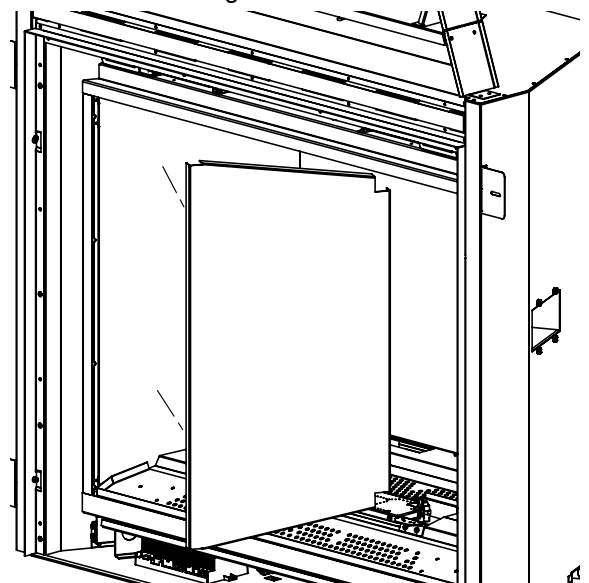


**Figure 80: Liner Front Edge Retainer Removal**

4. Remove the top left and right liner retainers, one at a time. The screws only have to be loosened as the retainers are slotted.
5. The liners can now be removed from the firebox. Remove the side liners first, then the rear liner. When removing the second side liner, brace the rear liner from falling forward.



**Figure 81: Top Liner Retainer Removal**



**Figure 82: Side Liner Removal**

## SECONDARY INSTALLATION

6. Prepare the new liners for installation. Wearing clean gloves is recommended when handling the liners, the ceramic material can irritate your skin. Take care not to damage the liners as they are very fragile and can chip / break easily. If handling porcelain liners, it is still a good idea to wear gloves as the oils from your fingers and stain the enameled coating. If the liners arrive damaged, please contact your ENVIRO dealer for replacement.
7. Install the new liners starting with the rear first. Note that any liners containing a brick pattern will have to be aligned with each other. The rear liner will only line up with the side liners in one position. Line up the top corners ahead of time to determine the installation direction. Re-install all retainers once liners are in position.
8. Re-install the light deflector and the remainder of the removed firebox parts from step 1.

### BURNER NICKEL STRANDING:

Two lengths of nickel stranding media are supplied with the fireplace to use in the left and right elevated burners. Adding the nickel stranding to the front slots of the burners creates an active glowing effect at the base of the flames.

**Installation** - Remove an elevated burner from the fireplace and use a pen, pencil or small screwdriver to loosely lay a single length of stranding into the front slot of the burner as shown below. The stranding may need to be slightly pulled apart to fill the height of the burner slot. The stranding should be just lightly placed in front of the burner ports but still retained within the slot. Packing the stranding too tight against the burner ports will effect flame appearance. Once installed, use a plain pair of scissors to trim off any askew or long lengths for a clean presentation. Nickel stranding are not installed on the backside of the burner.

Repeat for the other elevated burner.



**Figure 84: Nickel Strands Installed in Burner Slot**



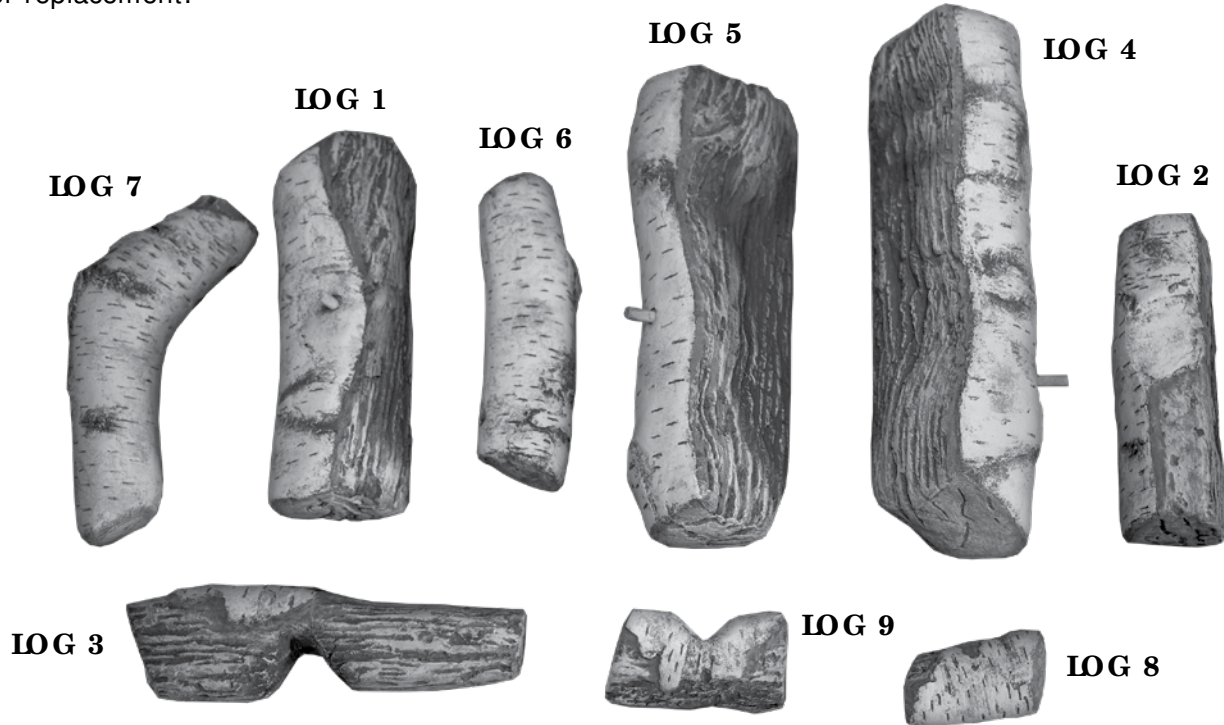
**Figure 83: Nickel Strands - Single Length**

Replacement sets of nickel stranding may be ordered from your Enviro dealer:  
50-4633 Nick Stranding Burner Media.

# SECONDARY INSTALLATION

## LOG SET INSTALLATION:

The placement of the logs is not arbitrary. If they are positioned incorrectly, the flames can be impinged and will not burn correctly creating a hazardous environment. Carefully set the logs in place using the figures provided. Wear vinyl gloves when handling the logs, the ceramic material can irritate your skin. Take care not to damage the logs as they are very fragile and can chip easily. If any logs arrive damaged, please contact your ENVIRO dealer for replacement.



## Step 1

Remove the left and right elevated burners from the firebox.

Fill the front and rear ember beds with the crushed glass media provided.

Fill the ends of the front ember bed with the supplied coals and add a few on top of the glass media for accents.

Evenly spread the supplied vermiculite on the middle pan burner. Only a thin layer is required.

**Warning: Too much vermiculite over burner ports may cause sooting or elongated flames.**



# SECONDARY INSTALLATION

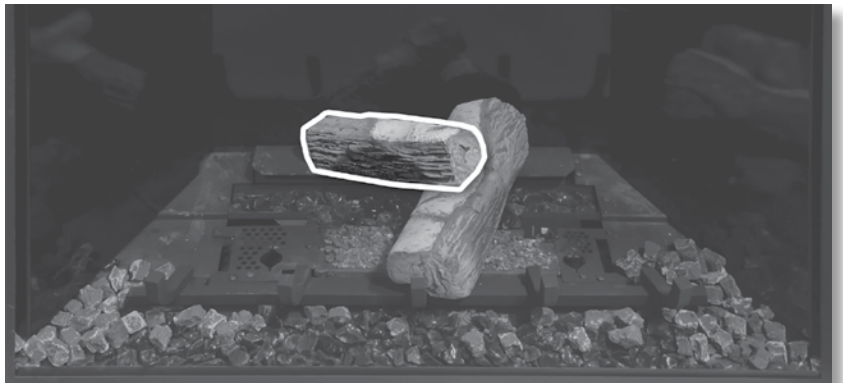
## Step 2

Place the front of **log 1** on the middle log grate arm and rest the rear on the steel air deflector. Keep the rear of **log 1** on the right side of the visible air channel.



## Step 3

Place **log 2** on top of **log 1**. Align the hole on the bottom side of **log 2** with the pin on **log 1**. Keep the rear of **log 2** on the left side of the visible air channel.



## Step 4

Place **log 3** to the left at an angle, resting across the burner pan and onto the log grate. Make sure the notch in the log aligns with the left burner post hole.



## Step 5

Re-install the right elevated burner with nickel stranding added, see SECONDARY INSTALLATION - BURNER NICKEL STRANDING. Confirm it is fully seated and does not interfere with **log 1**. Adjust **log 1** positioning if needed.



# SECONDARY INSTALLATION

## Step 6

Re-install the left elevated burner with nickel stranding added, see SECONDARY INSTALLATION - BURNER NICKEL STRANDING. Confirm it is fully seated and does not interfere with **log 2**. Adjust **log 2** positioning if needed.



## Step 7

Rest **log 4** on top of the right elevated burner. Align the bottom holes on **log 4** with the two pins on top of the burner.



## Step 8

Rest **log 5** on top of the left elevated burner. Align the bottom holes on **log 5** with the two pins on top of the burner.



## Step 9

Place the front of **log 6** onto the pin of **log 4** and rest the back on the steel log tray.



# SECONDARY INSTALLATION

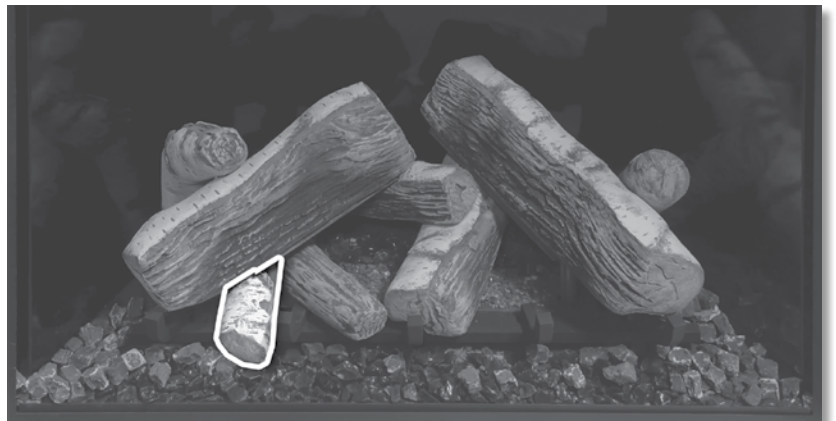
## Step 10

Place the front of **log 7** onto the pin of **log 5** and rest the back on the steel log tray.



## Step 11

Rest **log 8** on the log grate between the two left grate arms. Tuck it underneath the left elevated burner to hide the burner post.



## Step 12

Place **log 9** between the two right log grate arms, with the notch aligned around the burner post. Tuck it underneath the right elevated burner.



## Log Set Complete

The log set installation is now complete. Turn on the fireplace and let it fully warm up (15-20min). The flame appearance should be similar to what is shown.

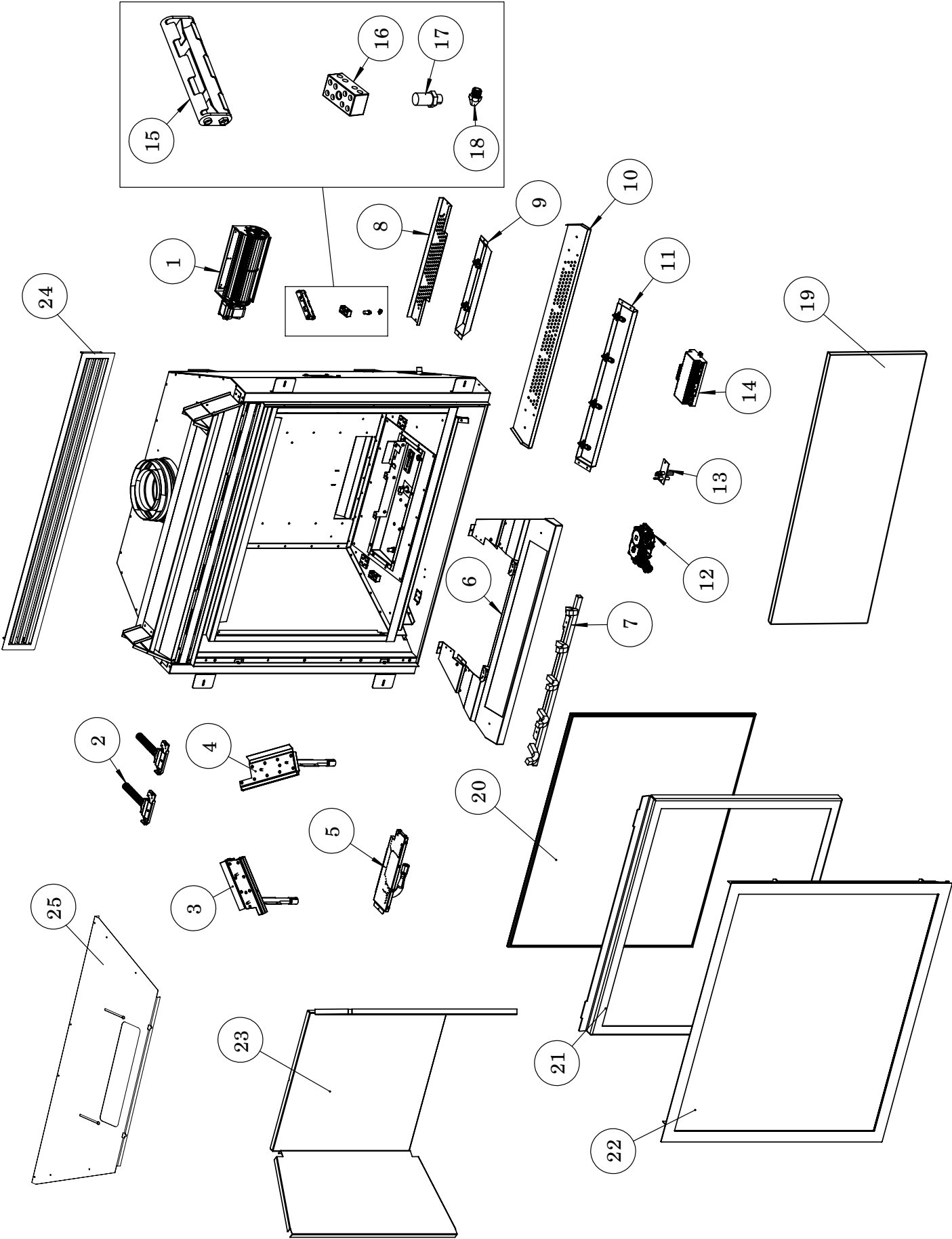


# TROUBLESHOOTING

**Table 12: Troubleshooting**

Problem	Possible Cause	Solution
Locking conditions	Reset the Proflame IFC board	· Turn the system off by pressing the ON/OFF button on the transmitter
		· After approximately 2 seconds press the ON/OFF button on the transmitter again.
		· In the manual flame control mode, use the down arrow button to reduce the flame to off, indicated by the word OFF displayed on the transmitter LCD screen.
		· Wait approximately 2 seconds and press the up arrow button, the ignition sequence will start.
Burners will not start	The pilot flame has gone out	· See “Pilot will not remain lit”
	The remote control is not working correctly	· Replace the batteries
	The thermostat is disconnected or set too high	· Set the thermostat to a lower temperature
	Problem with On/Off (X4) circuit	· Check the wiring connection at the X4 position on the IFC.
Flame lifting	Leak in vent pipe	· Check for leaks in vent connections
	Improper vent configuration	· Check vent configuration with manual
	Terminal may be re-circulating flue gases	· Check to see if terminal is on correctly
		· May need to install high wind termination cap. · Contact dealer
The heater has just been started	· Normal during start up: Minor flame lifting may occur on the elevated burners. Flames will settle as the fireplace heats up.	
Blue Flames	The heater has just been started	· Normal during start up: flame will yellow as the fireplace heats up. Let flames mature 15-20 minutes.
	Improper air shutter adjustment	· Adjust air shutter – contact your dealer
Glass fogs up	Normal condition: after the appliance warms up the glass will be clear.	** Due to additives in gas, glass may get hazy during operation** Clean as needed.
Flames are burning “dirty” or sooting	The logs are placed incorrectly	· Check log positioning
	Improper air shutter adjustment	· Increase primary air by opening the air shutter and/or by opening the vent restrictor
		· Check for proper venting and blockage of the vent termination
Incorrect rating input	· Check manifold pressure and clock input rating for over-firing	
Pilot will not remain lit	Problem with Flame Sensor circuit	· Check for proper connection of the Flame Sensor to the IFC board
		· Check pilot for full flame impingement around Flame Sensor
		· If flame is too small, check gas pressure, adjust pilot rate screw, check pilot head for damage
	· Ensure the ground wire is properly attached to the pilot mounting bracket and that it makes a good electrical connection.	
IPI/CPI Switch Position	· Manual switch is in the IPI position. This is normal operation when the fireplace burner is off.	

# PARTS DIAGRAM



# REPLACEMENT PARTS & OPTIONS LIST

**Table 13: Replacment Parts List**

#	Part Description	Part #
1	Convection Fan Only	50-3577
2	RZ41 Door Latch Spring Assembly (Set of 2)	50-4629
3	RZ41 Left Burner	50-4620
4	RZ41 Right Burner	50-4621
5	RZ41 Burner Pan	50-4622
6	RZ41 Log Tray Assembly	50-4625
7	RZ41 Log Grate	50-4624
8	RZ41 Rear Ember Tray	50-4628
9	RZ41 Rear Light Tray Assembly	50-4627
10	RZ41 Front Ember Tray	50-4626
11	RZ41 Front Light Tray Assembly	50-4625
-	35W Halogen Bulb	50-3291
-	High Temperature Wire Ceramic Halogen Socket	50-4632
-	4 AMP Glass Fuse	50-2076
12	SIT IPI Valve	50-2682
13	PSE IPI Pilot Assembly (2021)	50-4058
-	IPI LP Pilot Thimble (2021)	50-4080
14	Proflame 2 IFC	50-4103
-	Proflame 2 IFC Wire Harness (0.584.924)	50-3030
-	IFC ON/OFF Jumper Only	50-3205
-	Proflame 2 Remote - Wall Mount	50-3028
15	Battery Holder 4 x AA	50-3027
16	Ceramic Terminal Block 4 Pole	50-4632
17	Orifice #49 Long (for RZ41 Natural Gas)	50-4634
	Orifice #57 Long (for RZ41 Propane)	50-4635
18	Orifice #55 Bullet (for RZ41 Natural Gas)	50-4584
	Orifice #59 Bullet (for RZ41 Propane)	50-4636
19	RZ41 Non-Combustible Board	50-4639
20	RZ41 Door Glass with Gasket	50-4618
-	Dual Bulb Door Gasket (20ft)	50-2320
21	RZ41 Door Complete	50-4617
22	RZ41 Slim Face Complete - Painted Black	50-4619
-	G39/RZ41 Safety Screen	50-3578
-	RZ41 Owner's Manual	50-4641

**Table 14: Options List**

#	Part Description	Part #
23	G39/RZ41 Painted Black Liners	50-3536
-	G39/RZ41 Porcelain Liners	50-3498
-	G39/RZ41 Brown Brick Liners	50-3410
-	G39/RZ41 Black Brick Liners	50-3655
-	G39/RZ41 Herringbone Liners	50-3429
-	G39/RZ41 Ledgestone Liners	50-3497
24	RZ41 CSS Front Vent Trim Bezel	50-4640
25	RZ41 Power Vent Baffle	50-4642
-	1 Cup/Bag Black Vermiculite	50-3794
-	Nickel Stranding Burner Media (2 pcs)	50-4633
-	G39/RZ41 Crushed Glass Media - Cola (5 lbs)	50-4637
-	RZ41 Black & White Ember Media (7 cups)	50-4638
-	RZ41 Traditional Log Set	50-4615
-	RZ41 Birch Log Set	50-4616
-	NG to LP Stepper Motor Only	50-3753
-	LP to NG Stepper Motor Only	50-3870
-	Horizontal Power Vent Kit w/ 110ft wiring	50-3884
-	Vertical Power Vent Kit w/ 110ft wiring	50-4375
-	12 oz. Can of Metallic Black Touch Up Paint	PAINT-12-MB



# Warranty for Enviro Gas Products

Sherwood Industries Ltd. ("Sherwood") hereby warrants, subject to the terms and conditions herein set forth, this product against defects in material and workmanship during the specified warranty period starting from the date of original purchase at retail. In the event of a defect of material or workmanship during the specified warranty period, Sherwood reserves the right to make repairs or to assess the replacement of a defective product at Sherwood's factory. The shipping costs are to be paid by the consumer. All warranties by Sherwood are set forth herein and no claim shall be made against Sherwood on any oral warranty or representation.

## Conditions

- A completed warranty registration must be submitted to Sherwood within 90 days of original purchase via the online warranty registration page or via the mail-in warranty registration card provided. Have the installer fill in the installation data sheet in the back of the manual for warranty and future reference.
- This warranty applies only to the original owner in the original location from date of install.
- The unit must have been properly installed by a qualified technician or installer, and must meet all local and national building code requirements.
- The warranty does not cover removal and re-installation costs.
- Sherwood Industries Ltd. reserves the right to make changes without notice.
- Sherwood Industries Ltd. and its employees or representatives will not assume any damages, either directly or indirectly caused by improper usage, operation, installation, servicing or maintenance of this appliance.
- A proof of original purchase must be provided by you or the dealer including serial number.
- This warranty does not cover any discoloration of the safety screen mesh.

## Exclusions

An expanded list of exclusions is available at [www.enviro.com/help/warranty.html](http://www.enviro.com/help/warranty.html)

This warranty does not cover:

- Damage as a result of improper usage or abuse.
- Damage caused from over-firing due to incorrect setup or tampering.
- Damage caused by incorrect installation.

## To the Dealer

- Provide name, address and telephone number of purchaser and date of purchase.
- Provide date of purchase. Name of installer and dealer. Serial number of the appliance. Nature of complaint, defects or malfunction, description and part # of any parts replaced.
- Pictures or return of damaged or defective product may be required.

## To the Distributor

- Sign and verify that work and information are correct.

### Sherwood Industries Ltd.

6782 Oldfield Road, Victoria, BC . Canada V8M 2A3  
 Online warranty registration: [www.enviro.com/warranty/](http://www.enviro.com/warranty/)

Category	One Year	Two Year	Limited Lifetime (7yr)
Parts <sup>1,2</sup> (unit serial number required)		✓	
Firebox Liner Panels <sup>3</sup>		✓	
Firebox			✓
Heat Exchanger			✓
Burner			✓
Ceramic Logs <sup>4</sup>			✓
Ceramic Glass <sup>5</sup>	✓		
Pedestal / Legs (excluding finish)			✓
Door Assembly			✓
Surround Panels (excluding finish)			✓
Exterior Panels (excluding finish)			Up to 5 years
Electrical Components		✓	
Exterior Surface Finishing	✓		
Labour	✓		

<sup>1</sup> Whereas warranty has expired, replacement parts will be warranted for 90 days from part purchase date. Labour not included. Unit serial number required.

<sup>2</sup> Westport Fan Kit covered for up to 5 years from purchase date. Labour not included. Unit serial required.

<sup>3</sup> Excluding damage to the finish caused by improper setup of the appliance, or color changes.

<sup>4</sup> Log set and panels excludes wear and tear or breakage caused by cleaning or service.

<sup>4</sup> Glass is covered for thermal breakage. Photos of box, inside of door, and unit serial # must be supplied for breakage due to shipping.

<sup>6</sup> Exterior Surface finishing covers plating, enamel or paint and excludes colour changes, chipping, and fingerprints. Travel costs not included.

# INSTALLATION DATA SHEET

The following information must be recorded by the installer for warranty purposes and future reference.

NAME OF OWNER:  
\_\_\_\_\_  
  
ADDRESS:  
\_\_\_\_\_  
\_\_\_\_\_  
\_\_\_\_\_  
  
PHONE: \_\_\_\_\_

NAME OF DEALER:  
\_\_\_\_\_  
  
ADDRESS:  
\_\_\_\_\_  
\_\_\_\_\_  
\_\_\_\_\_  
  
PHONE: \_\_\_\_\_

MODEL: \_\_\_\_\_  
SERIAL NUMBER: \_\_\_\_\_  
DATE OF PURCHASE: \_\_\_\_\_ (dd/mm/yyyy)  
DATE OF INSTALLATION: \_\_\_\_\_ (dd/mm/yyyy)  
  
 NATURAL GAS (NAT)       PROPANE(LPG)  
  
INLET GAS PRESSURE: \_\_\_\_\_ in wc  
MAIN BURNER ORIFICE: \_\_\_\_\_ # DMS  
PILOT ORIFICE # \_\_\_\_\_ OR \_\_\_\_\_ in diam.  
INSTALLER'S SIGNATURE:  
\_\_\_\_\_

NAME OF INSTALLER:  
\_\_\_\_\_  
  
ADDRESS:  
\_\_\_\_\_  
\_\_\_\_\_  
\_\_\_\_\_  
  
PHONE: \_\_\_\_\_

MANUFACTURED BY:  
SHERWOOD INDUSTRIES LTD.  
6782 OLDFIELD RD. SAANICHTON, BC, CANADA V8M 2A3  
www.enviro.com  
October 2024  
C-17067