



Ri30

IPI GAS FIREPLACE INSERT

OWNER'S MANUAL

WARRANTY REGISTRATION
enviro.com/warranty



WARNING: If the information in this manual is not followed exactly, a fire or explosion may result causing property damage, personal injury or loss of life. Installation and service must be performed by a qualified installer, service agency or the gas supplier.

SAFETY PRECAUTIONS



WARNING:

FIRE OR EXPLOSION HAZARD

Failure to follow safety warnings exactly could result in serious injury, death, or property damage.

- Do not store or use gasoline or other flammable vapors and liquids in the vicinity of this or any other appliance.

- **WHAT TO DO IF YOU SMELL GAS**
 - Do not try to light any appliance.
 - Do not touch any electrical switch; do not use any phone in your building.
 - Leave the building immediately.
 - Immediately call your gas supplier from a neighbor's phone. Follow the gas supplier's instructions.
 - If you cannot reach your gas supplier, call the fire department.

- Installation and service must be performed by a qualified installer, service agency or the gas supplier.

INSTALLER:

Leave this manual with the appliance.

CONSUMER:

Retain this manual for future reference.

This appliance is only for use with the type of gas indicated on the rating plate. This appliance is not convertible for use with other gases, unless a certified kit is used.

Massachusetts installations (Warning): This product must be installed by a licensed plumber or gas fitter when installed within the Commonwealth of Massachusetts. Other Massachusetts code requirements: Flexible connector must not be longer than 36in., a shut off valve must be installed; only direct vent sealed combustion products are approved for bedrooms/bathrooms. A carbon monoxide detector is required in all rooms containing gas fired direct vent appliances. The fireplace damper must be removed or welded in the open position prior to installation of a fireplace insert.

SAFETY PRECAUTIONS

FOR SAFE INSTALLATION AND OPERATION OF YOUR “ENVIRO” HEATER, PLEASE CAREFULLY READ THE FOLLOWING INFORMATION:

- All ENVIRO gas-fired appliances must be installed in accordance with their instructions. Carefully read all the instructions in this manual first. Consult the building authority having jurisdiction to determine the need for a permit prior to commencing the installation.
- **NOTE:** Failure to follow these instructions could cause a malfunction of the fireplace, which could result in death, serious bodily injury, and/or property damage.
- Failure to follow these instructions may also void your fire insurance and/or warranty.

GENERAL

• Installation and repair should be done by a qualified service person. The appliance should be inspected before the first use and, at least, annually by a qualified service person. More frequent cleaning may be required due to excessive lint from carpeting, bedding material, etc. It is imperative the control compartments, burners and circulating air passageways of the appliance be kept clean.

• Due to high temperatures, the appliance should be located out of high traffic areas and away from furniture and draperies.

Children and adults should be alerted to the hazards of high surface temperatures and should stay away to avoid burn or clothing ignition.

• Young children should be carefully supervised when in the same room as the appliance. Toddlers, young children and others may be susceptible to accidental contact burns. A physical barrier is recommended if there are at risk individuals in the house. To restrict access to a fireplace or stove install an adjustable safety gate to keep toddlers, young children and other at risk individuals out of the room and away from hot surfaces. Any safety screen, guard, or barrier removed for servicing an appliance must be replaced prior to operating the appliance.

• Clothing or other flammable materials should not be placed on or near the appliance.

• A barrier designed to reduce the risk of burns from the hot viewing glass is provided with this appliance and shall be installed for the protection of children and other at-risk individuals. If the barrier becomes damaged, the barrier shall be replaced with the manufacturer’s barrier for this appliance

FOR YOUR SAFETY

• Installation and service must be performed by a qualified installer, service agency or gas supplier.

• This installation must conform to local codes or, in the absence of local codes, with the National Fuel Gas Code, ANSI Z223.1/NFPA 54, or the Natural Gas and Propane Installation Code, CSA B149.1.

• To prevent injury, do not allow anyone who is unfamiliar with the stove to operate it.

• To prevent injury, if the pilot or pilot and burners have gone out on their own, open the glass door and wait 5 minutes to air out before attempting to re-light the stove.

• Always keep the area around these appliances clear of combustible material, gasoline and other flammable liquids and vapours.

• These appliances should not be used as a drying rack for clothing or for hanging Christmas stockings/decorations.

• Due to the paint curing on the stove, a faint odor and slight smoking will likely be noticed when the stove is first used. Open a window until the smoking stops.

Always connect this gas stove to a vent system and vent to the outside of the building envelope. Never vent to another room or inside the building. Make sure the specified vent pipe is used, properly sized and of adequate height to provide sufficient draft. Inspect the venting system annually for blockage and signs of deterioration.

WARNING: Failure to position the parts in accordance with the diagrams in this booklet, or failure to use only parts specifically approved with this appliance, may result in property damage or personal injury.

WARNING: Do not operate with the glass front removed, cracked or broken. Replacement of the glass should be done by a licensed or qualified service person.

• Never use solid fuels such as wood, paper, cardboard, coal, or any flammable liquids, etc., in this appliance.

• Do not use this appliance if any part has been under water. Immediately call a qualified service technician to inspect the appliance and to replace any part of the control system or any gas control which has been under water.

• Do not abuse the glass by striking it or slamming the door shut.

• If the Ri30 unit is pulled out of its installation, and the vent-air intake system is disconnected for any reason, ensure that the vent-air intake pipes are reconnected and re-sealed in accordance to the instructions noted in INITIAL INSTALLATION - VENTING.

 **DANGER**



HOT GLASS WILL CAUSE BURNS
DO NOT TOUCH GLASS UNTIL COOLED.
NEVER ALLOW CHILDREN TO TOUCH GLASS.

A barrier designed to reduce the risk of burns from the hot viewing glass is provided with this appliance and must be installed for the protection of children and other at-risk individuals.

TABLE OF CONTENTS

Safety Precautions.....	2
Table of Contents.....	4
Codes And Approvals.....	5
Specifications.....	6
Rating Label Location.....	6
Dimensions.....	6
Install Depths.....	6
Ri30 Options Dimensions.....	7
Operating Instructions.....	8
Lighting and Turning Off Instructions.....	8
Normal Sounds During Operation.....	9
Remote Control Operations.....	9
System Description.....	9
Technical Data.....	9
Transmitter.....	9
Integrated Fireplace Controller (IFC).....	10
Operating Procedure.....	11
Maintenance And Service.....	14
Cleaning the Painted Surfaces.....	14
Surround Removal.....	15
Glass Door Removal.....	15
Cleaning the Glass.....	16
Cleaning the Firebox.....	16
Replacing the Glass.....	16
Check Pilot and Burner Flames.....	16
Burner Removal.....	17
Air Shutters	18
Ember Lights - Bulb Replacement.....	19
Fan Replacement	20
Fuel Conversion.....	21
Initial Installation.....	23
Clearances to Combustibles.....	23
Minimum Fireplace Size.....	23
Non-Combustible Build Out.....	23
Venting.....	23
Exhaust Restrictor.....	26
Installing the Ri30.....	25
Zero Clearance Fireplace Installation.....	29
Electrical Requirements.....	29
Gas Line Connection.....	31
Adjusting The Pilot Flame.....	32
Secondary Installation.....	33
Optional Base Shelf & Riser.....	33
Surround Panel Installation.....	34
Optional Trimmable Panels.....	35
Log Set Installation.....	36
Trouble Shooting.....	39
Parts List.....	42
Parts Diagram - Components.....	43
Warranty.....	44
Installation Data Sheet.....	46

CODES AND APPROVALS

DIRECT VENT: This type is identified by the suffix DV. This appliance draws all of its air for combustion from outside the dwelling, through a specially designed vent pipe system. This appliance has been tested and approved for installations from 0 feet to 4500 feet (1372 m) above sea level.

In the USA: The appliance may be installed at higher altitudes. Please refer to your American Gas Association guidelines which state: the sea level rated input of Gas Designed Appliances installed at elevations above 2000 (610 m) feet is to be reduced 4% for each 1000 feet (305 m) above sea level. Refer also to local authorities or codes which have jurisdiction in your area regarding the de-rate guidelines.

In Canada: When the appliance is installed at elevations above 4500 feet (1372 m), the certified high altitude rating shall be reduced at the rate of 4% for each additional 1000 feet (305 m).

- This appliance has been tested by INTERTEK and found to comply with the established VENTED GAS FIREPLACE HEATER standards in CANADA and the USA as follows:

DI RECT VENTED GAS FI REPLACE I NSERT HEATER
TESTED AND LISTED TO: ANSI Z21.88 / CSA 2.33 VENTED GAS FIREPLACE HEATERS
CSA 2.17 GAS FIRED APPLIANCES FOR HIGH ALTITUDES
CSA P.4.1 TESTING METHOD FOR MEASURING ANNUAL FIREPLACE EFFICIENCY

This ENVIRO Ri30 Fireplace Insert:

- Has been certified for use with either natural or propane gases. (See rating label.)
- Is not for use with solid fuels.
- Is approved for bedroom or bed sitting room. (**IN CANADA:** must be installed with a permanent wall thermostat for bedroom installations. Consult the authority having local jurisdiction in your area. **IN USA:** see current ANSI Z223.1 for installation instructions.)
- Must be installed in accordance with local codes. If none exist, use current installation code CAN/CGA B149 in Canada or ANSI Z223.1/NFPA 54 in the USA.
- Must be properly connected to an approved venting system and not connected to a chimney flue serving a separate solid-fuel burning appliance.
- Is not approved for closet or recessed installations.

IMPORTANT NOTICE (Regarding first fire up): When the unit is turned on for the first time, it should be turned onto high without the fan on for the first 4 hours. This will cure the paint, logs, gasket material and other products used in the manufacturing process. It is advisable to open a window or door, as the unit will start to smoke and can irritate some people. After the unit has gone through the first burn, turn the unit off, let the unit get cold then remove the glass door and clean it with a good gas fireplace glass cleaner, available at your local ENVIRO dealer. See "DOOR REMOVAL" and "CLEANING THE GLASS" sections.

COLD CLIMATES:

NOTE: In cold climates, additional insulation may be used on some venting. It is recommended in cold climates to wrap the exhaust and intake venting for the final few feet before termination.



SPECIFICATIONS

RATING LABEL LOCATION:

The rating label is located in the left side of the unit.

DIMENSIONS:

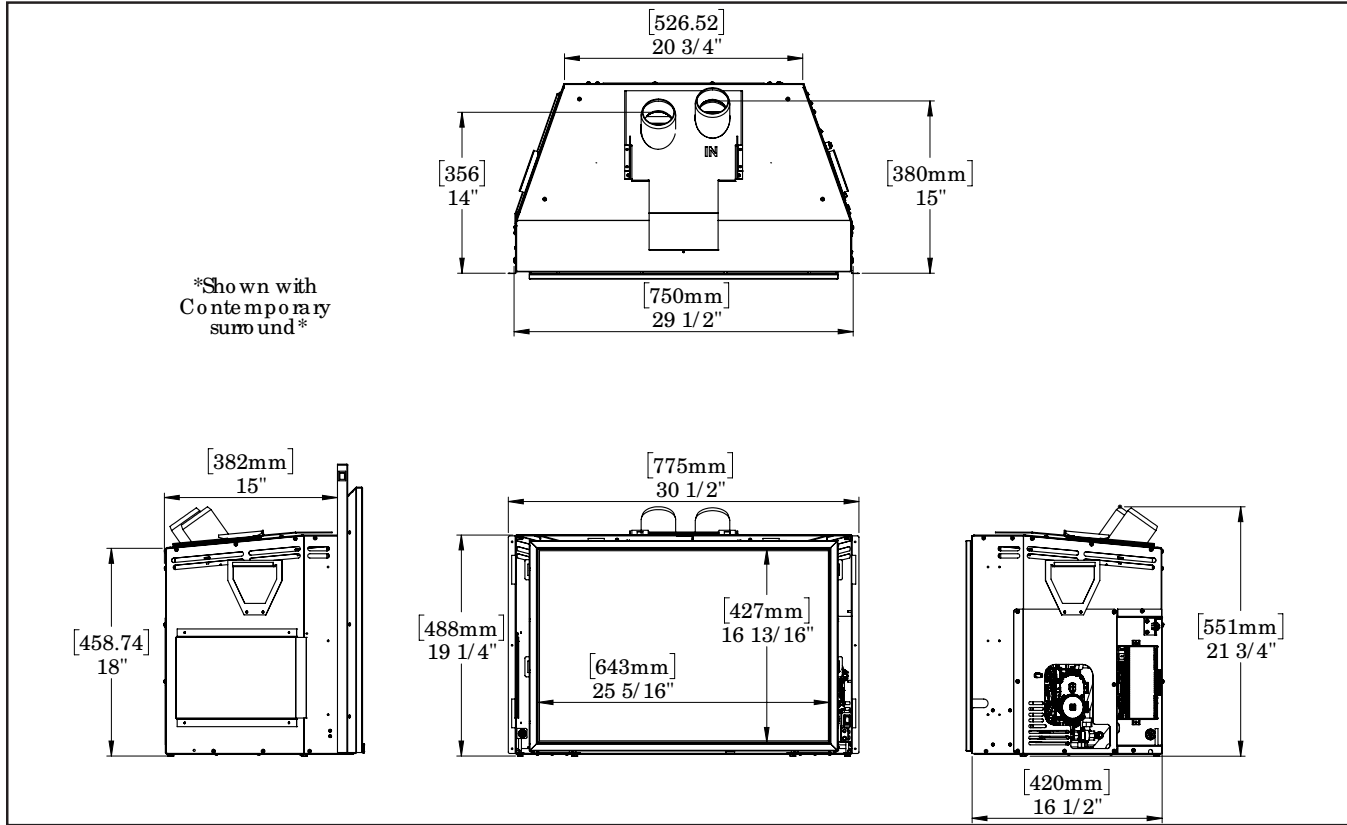

Figure 1: Ri30 Exterior Dimensions

INSTALL DEPTH:

The Ri30 has a minimum install depth of 15" (382mm). The table below shows what depth of install is required with each surround panel.

Surround Panel	Required Install Depth
Contemporary Surround (50-4688)	15" (382mm)
Galiano Surround (50-4687) Slim Surround (50-4689) Forgeworks Surround (50-4690)	16" (406mm)

Table 1: Install Depths

SPECIFICATIONS

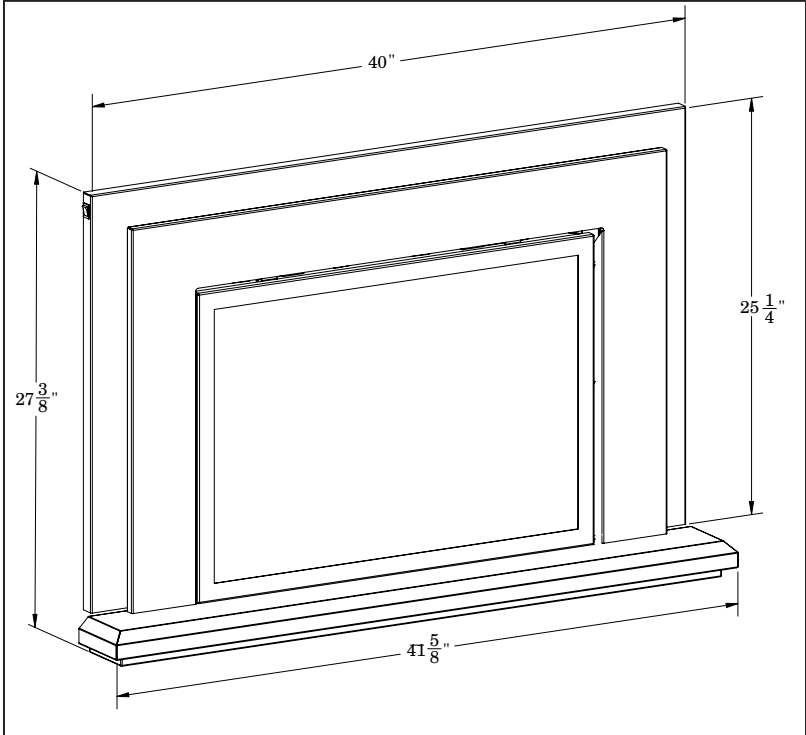

Figure 2: Ri30 Contemporary Surround with Base Shelf and Riser.

Table 2: Ri30 Options Dimensions.

Surround	Height	Width
Contemporary Surround	25 1/4" (641mm)	40" (1016 mm)
Slim Surround	22 1/4" (565 mm)	33 1/2" (851 mm)
Galiano Surround	25 1/4" (641mm)	40" (1016 mm)
Forgeworks Surround	26 3/8" (670mm)	40" (1016 mm)
Trimmable Surround	38" (965 mm)	46" (1168 mm)

OPERATING INSTRUCTIONS

For Your Safety, Read Safety Precautions And Lighting Instructions Before Operating

WARNING: IF YOU DO NOT FOLLOW THESE INSTRUCTIONS EXACTLY A FIRE OR EXPLOSION MAY RESULT, CAUSING PROPERTY DAMAGE, PERSONAL INJURY OR LOSS OF LIFE.

LIGHTING AND TURNING OFF INSTRUCTIONS:

FOR YOUR SAFETY READ BEFORE OPERATING

WARNING:IF YOU DO NOT FOLLOW THESE INSTRUCTIONS EXACTLY, A FIRE OR EXPLOSION MAY RESULT CAUSING PROPERTY DAMAGE, PERSONAL INJURY OR LOSS OF LIFE.

A. This appliance is equipped with an ignition device which automatically lights the pilot. Do not try to light the pilot by hand.

B. BEFORE OPERATING smell all around the appliance area for gas. Be sure to smell next to the floor because some gas is heavier than air and will settle on the floor.

WHAT TO DO IF YOU SMELL GAS:

- Do not try to light any appliance.
- Do not touch any electrical switch; do not use any phone in your building.
- Immediately call your gas supplier from a neighbor's phone. Follow the gas supplier's instructions.
- If you cannot reach your gas supplier, call the fire department.

C. Use only your hand to push in or turn the gas control knob. Never use tools. If the knob will not push in or turn by hand, don't try to repair it, call a qualified service technician. Force or attempted repair may result in a fire or explosion.

D. Do not use this appliance if any part has been under water. Immediately call a qualified service technician to inspect the appliance and to replace any part of the control system and any gas control which has been under water.

OPERATING INSTRUCTIONS

1. STOP! Read the safety information above on this label.

2. Read the owner's manual including the section on "Remote Control" operation.

3. Set the thermostat to the lowest setting.

4. Turn off all electric power to the appliance.

5. Do not attempt to light the pilot by hand.

6. Wait five (5) minutes to clear out any gas. Then smell for gas, including near the floor. If you smell gas, STOP! Follow "B" in the safety information above on this label. If you don't smell gas, go to the next step.

7. Turn on all electric power to the appliance.

8. Using the remote control, set thermostat to desired setting, or press the ON/OFF key on the remote. "ON" will be indicated on the display of the remote and an audible "beep" will be heard at the unit to indicate the command has been received.

9. This appliance is equipped with a completely automatic ignition and lighting control. The control will attempt to light the pilot several times if necessary. If it is unsuccessful, it will discontinue operations. If the appliance will not operate, follow the instructions "To Turn Off Gas To Appliance" and call your service technician or gas supplier.

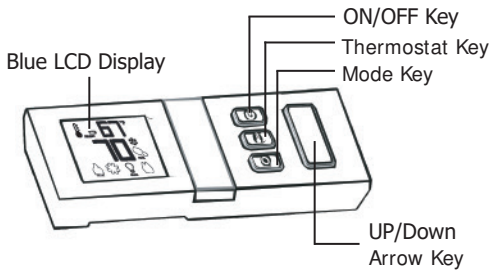

The diagram shows a white remote control with a blue LCD display on the left side. To the right of the display are four buttons: a large rectangular button labeled 'ON/OFF Key', a smaller square button labeled 'Thermostat Key', another smaller square button labeled 'Mode Key', and a vertical arrow button labeled 'UP/Down Arrow Key'.

TO TURN OFF GAS TO APPLIANCE

1. Set thermostat to lowest setting, or press the ON/OFF Key. "OFF" will be indicated on the display and an audible "Beep" will be heard at the unit to indicate the command has been received.

2. Turn off all electric power to the appliance if service is to be performed.

Figure 3: Lighting instruction label.

OPERATING INSTRUCTIONS

NORMAL SOUNDS DURING OPERATION:

Component	Sound & Reason
Fire Box	Creaking when heating up or cooling down.
Burner	Light pop or poof when turned off; this is more common with LP units.
Pilot Flame	Quiet whisper while the pilot flame in on.
Blower / Fan	Air movement that increases and decreases with the speed of the blower.
Gas Control Valve	Dull click when turning on or off, this is the valve opening and closing.

Table 3: Normal Sound

REMOTE CONTROL OPERATIONS:

The Proflame 2 GTMFLSA is a modular remote control system that directs the functions of the Ri30. The Proflame 2 GTMFLSA is configured to control the on/off main burner operation, its flame levels and provides on/off and Smart thermostatic control of the appliance. The system controls a remotely actuated top light, as well as bottom lights and fan speed each through six (6) levels.

SYSTEM DESCRIPTION:

The Proflame 2 Remote Control System consists of two (2) elements:

1. Proflame 2 Transmitter.
2. Integrated Fireplace Controller (IFC) and wiring harness to connect to the gas valve, stepper motor battery holder, convection fan, and lights.

ATTENTION!

- TURN "OFF" THE MAIN GAS SUPPLY OF THE APPLIANCE DURING INSTALLATION OR MAINTENANCE OF THE IFC.
- TURN "OFF" MAIN GAS SUPPLY TO THE APPLIANCE PRIOR TO REMOVING OR REINSERTING THE BATTERIES IN THE BATTERY HOLDER

TECHNICAL DATA

Transmitter (Remote Control):

Supply voltage: 4.5 V (three 1.5 V AAA batteries)
Radio frequency: 315 MHz

Integrated Fireplace Controller (IFC):

Supply voltage: AC IN - 120 V / 60 Hz
Battery Backup IN - 6 Vdc - 200mA (four 1.5 V AA batteries)
Spark voltage / frequency: >10kV / 1Hz
Comfort modulating fan: 120 V / 60 Hz / 2A
Auxiliary: 120 V / 60 Hz / 5A

TRANSMITTER:

The Proflame 2 Transmitter is a remote control with a blue backlit lcd display. It uses a streamline design with a simple button layout and informative lcd readout (Figure 4). The Transmitter is powered by three (3) AAA type batteries. A Mode Key is provided to Index between the features and a Thermostat Key is used to turn on/off or index through Thermostat functions (Figure 4 & 5).

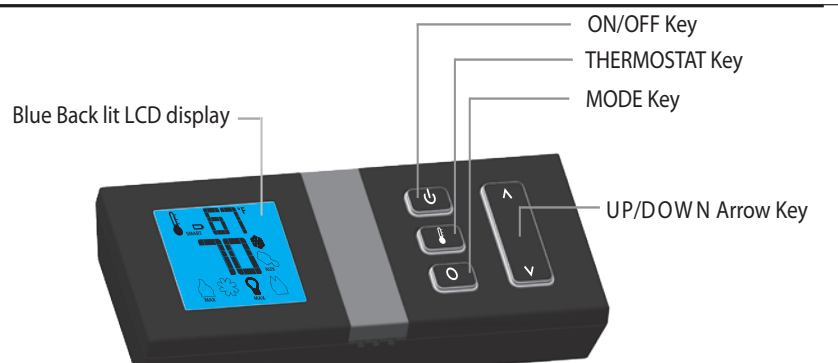

Figure 4: Proflame 2 Transmitter

OPERATING INSTRUCTIONS

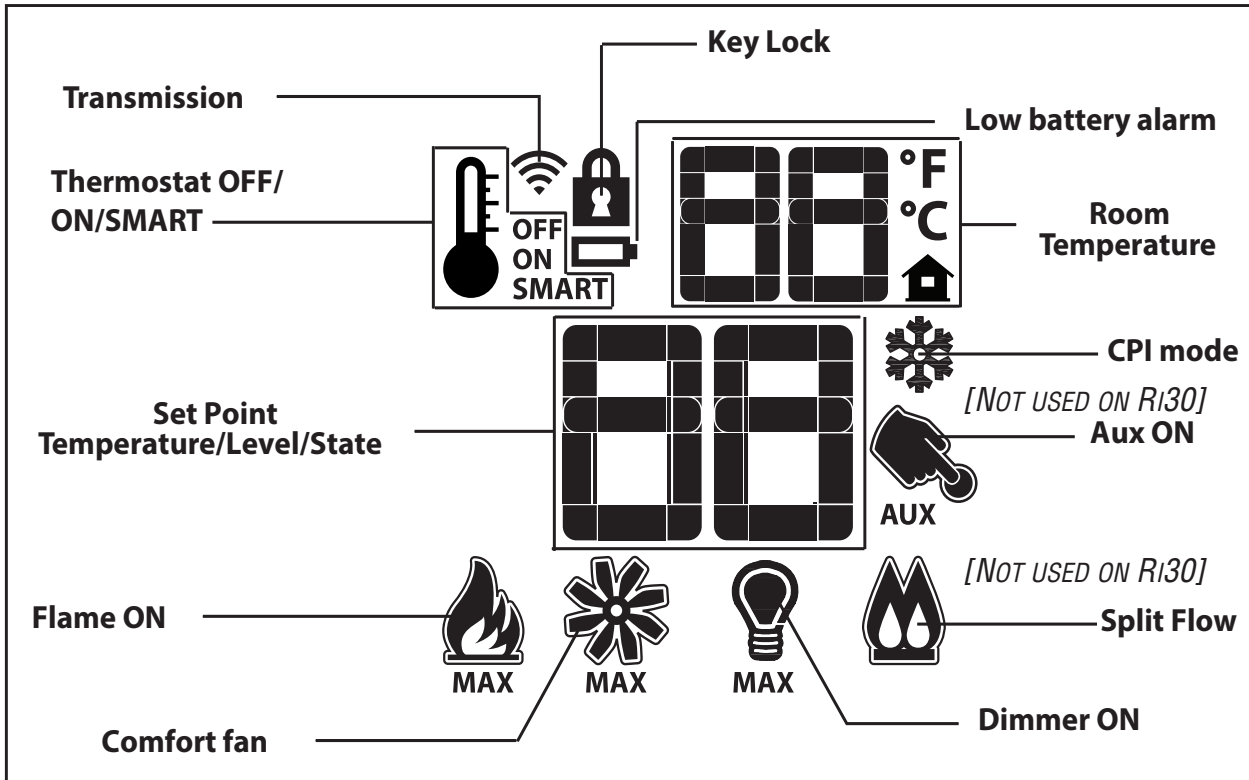

Figure 5: Proflame 2 Transmitter LCD Screen.

INTEGRATED FIREPLACE CONTROLLER (IFC):

The Proflame 2 IFC (Figure 6) connects directly to the gas valve, stepper motor, pilot, convection fan, and accent lights with wiring harnesses. The IFC is mainly powered by 120 VAC but can also run off a battery backup four (4) AA type batteries for shorter periods of time. The IFC accepts commands via radio frequency from the Transmitter to operate the appliance in accordance with the particular Proflame 2 system configuration. The IFC has a red reset button at the front right corner that is used to synchronize the Transmitter when using the for the first time, or after the batteries have been replaced. There is also a remote reset button located on the lower right side cabinet (Figure 7)

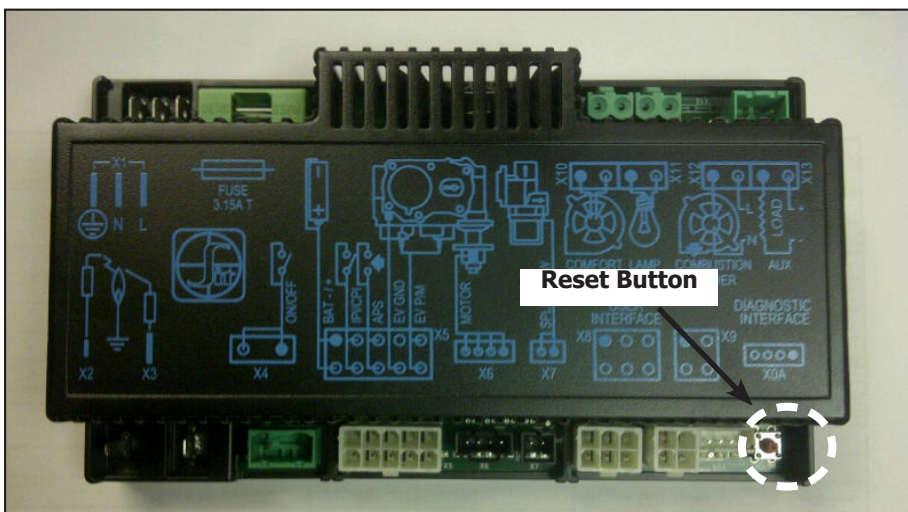

Figure 6: Integrated Fireplace Controller

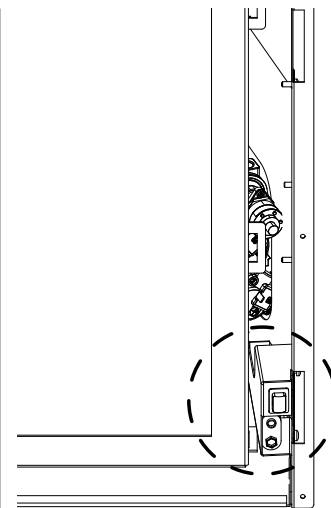

Figure 7: Remote Reset button

OPERATING INSTRUCTIONS

OPERATING PROCEDURE:

Initializing The System For The First Time

Install the four (4) AA batteries into the IFC battery holder. Note the polarity of the battery and insert into the battery bay as indicated on the body of the battery holder. Press and release the reset button (see Figure 7).

The IFC will “beep” three (3) times to indicate that it is ready to synchronize with a Transmitter. Install the three (3) AAA type batteries in the Transmitter battery bay, located on the base of the Transmitter. With the batteries already installed in the Transmitter, push the ‘ON’ button. The IFC will “beep” four (4) times to indicate the Transmitter’s command is accepted and sets to the particular code of that Transmitter. The system is now initialized.

Temperature Indication Display

With the system in the “OFF” position, press the Thermostat Key and the Mode Key at the same time. Look at the LCD screen on the transmitter to verify that a °C or °F is visible to the right of the Room Temperature display (see Figure 8).

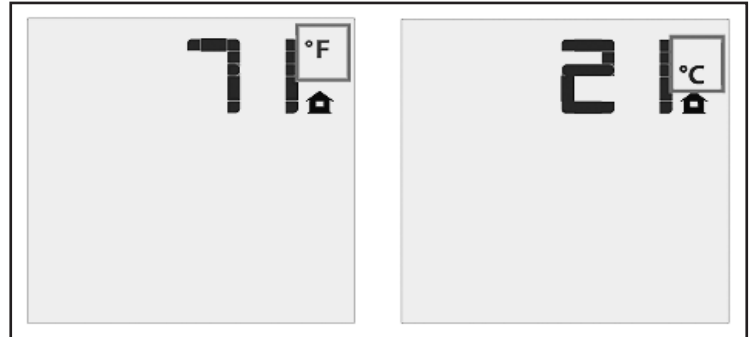

Figure 8: Remote Control Display in Fahrenheit and Celsius.

Turn on the Appliance

Press the ON/OFF Key on the Transmitter. The Transmitter display will show all active Icons on the screen. A single “beep” from the Receiver will confirm reception of the command and will commence to first ignite the pilot light, followed by the main burner. This should take about 10 seconds to complete.

Turn off the Appliance

Press the ON/OFF Key on the Transmitter. The Transmitter LCD display will only show the room temperature and Icon (see Figure 9). A single “beep” from the IFC confirms reception of the command and both the pilot light (if the unit is not set to continuous pilot) and main burner will turn off.

Room Thermostat (Transmitter Operation)

The Remote Control can operate as a room thermostat. The thermostat can be set to a desired temperature to control the comfort level in a room. To activate this function, press the Thermostat Key (see Figure 4). The LCD display on the Transmitter will change to show that the room thermostat is “ON” and the set temperature is now displayed (see Figure 9). To adjust the set temperature, press the Up or Down Arrow Keys until the desired set temperature is displayed on the LCD screen of the Transmitter.

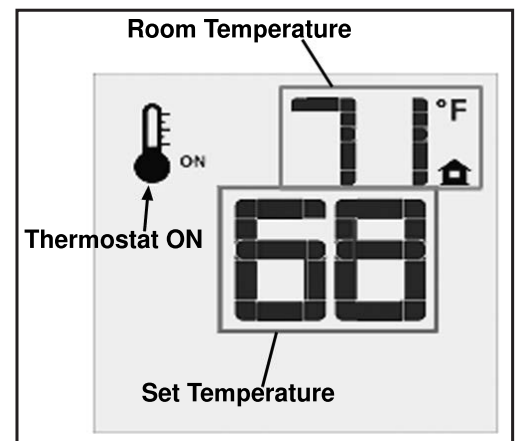

Figure 9: Remote Control Displays Set Temperature.

Smart Thermostat (Transmitter Operation)

The Smart Thermostat function adjusts the flame height in accordance to the difference between the set point temperature and the actual room temperatures. As the room temperature gets closer to the set point the Smart Function will modulate the flame down. To activate this function, press the Thermostat Key (Figure 4) until the word “SMART” appears to the right of the temperature bulb graphic (Figure 10). To adjust the set temperature, press the Up or Down Arrow Keys until the desired set temperature is displayed on the LCD screen of the Transmitter.

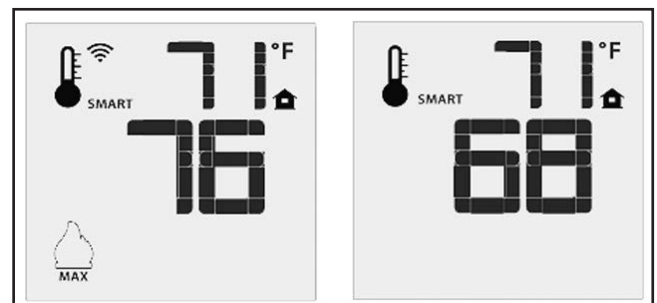

Figure 10: Remote Control's Smart Flame Function.

OPERATING INSTRUCTIONS

Remote Flame Control

The Proflame 2 GTMF has six (6) flame levels. With the system on, and the flame level at the maximum in the appliance, pressing the Down Arrow Key once will reduce the flame height by one step until the flame is turned off. The Up Arrow Key will increase the flame height each time it is pressed. If the Up Arrow Key is pressed while the system is on but the flame is off, the flame will come on in the high position (refer to Figure 11 below). A single "beep" will confirm reception of the command.

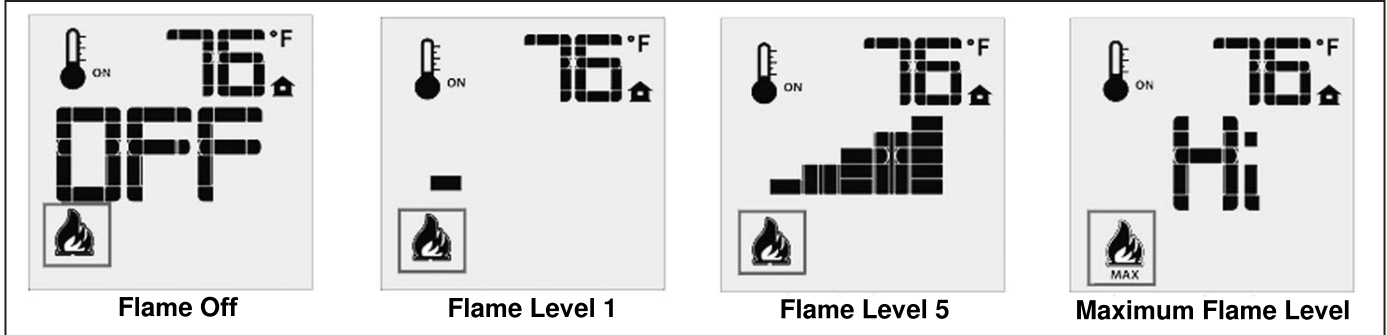

Figure 11: Remote Control's Flame Levels.

Fan Control

The Ri30 comes with a convection fan that can be controlled with the Transmitter. The fan speed can be adjusted through six (6) speeds. To control the fan press the MODE key (Figure 4) to index to the fan control icon (Figure 12). Use the UP/DOWN arrow keys to turn on, off, or adjust the fan speed (Figure 12). A single beep from the IFC will confirm the command has been received.

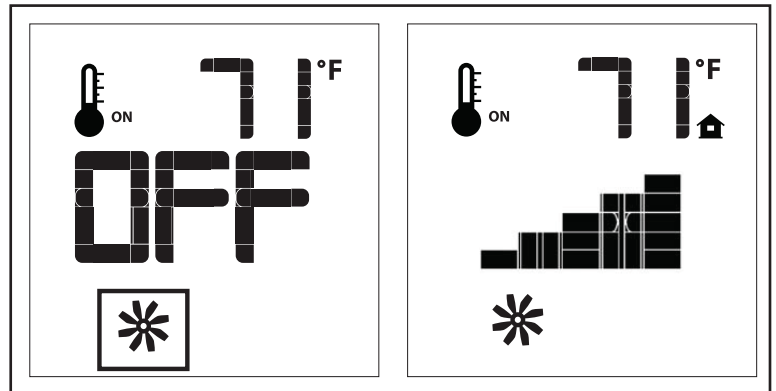

Figure 12: Fan Control

Ember Lights Control

The ember lights at the front of the fireplace can be controlled with the Transmitter. The lights can be adjusted through six (6) levels. To adjust the brightness of the lights press the MODE key (Figure 4) to index to the light control icon (Figure 13). Use the UP/DOWN arrow keys to turn on, off, or adjust the brightness (Figure 13). A single beep from the IFC will confirm the command has been received.

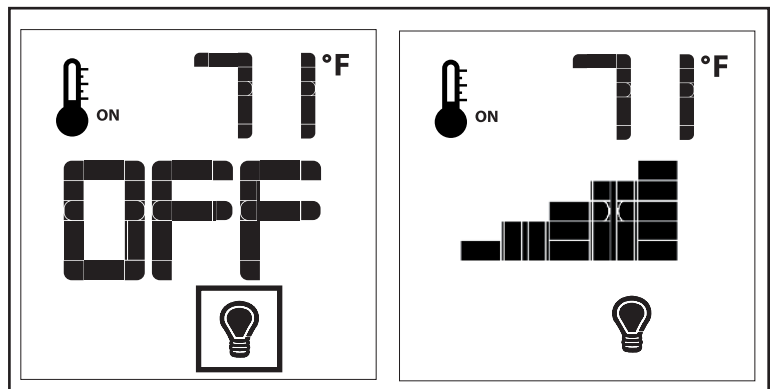

Figure 13: Bottom Light Control

Split Flow Control

This function is not used on the Ri30 and can be disregarded.

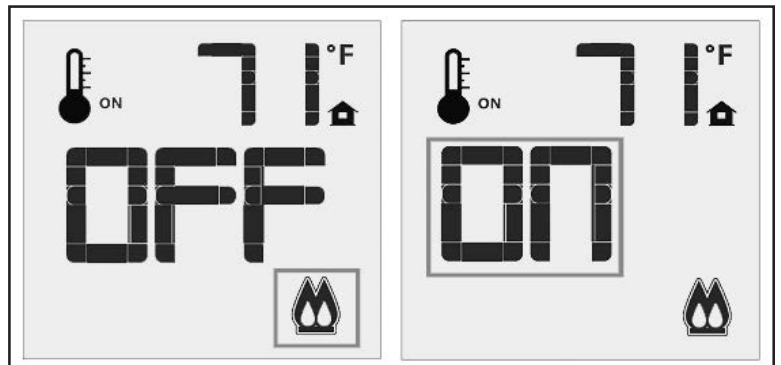

Figure 14: Split Flow Control

OPERATING INSTRUCTIONS

Aux Control

This function is not used on the Ri30 and can be disregarded.

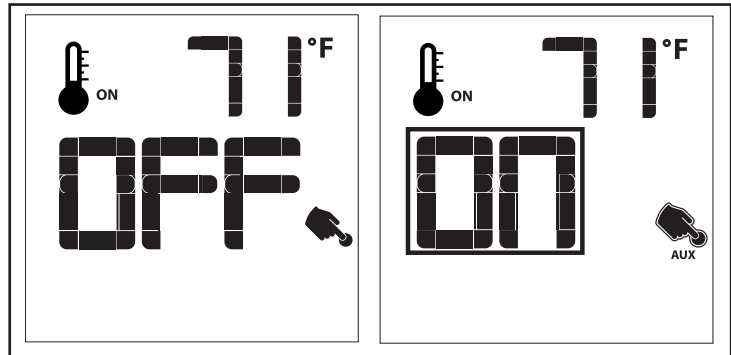

Figure 15: Aux Control

Key lock

This function will lock the keys to avoid unsupervised operation. To activate this function, press the MODE and UP keys at the same time and the a lock will appear (see Figure 16). To de-activate this function, press the MODE and UP Keys at the same time.



Figure 16: Remote Control Locked.

Low Battery Power Detection

Transmitter: The life span of the remote control batteries depends on various factors: quality of the batteries used, the number of ignitions of the appliance, the number of changes to the room thermostat set point, etc. When the Transmitter batteries are low, a Battery Icon will appear on the LCD display of the Transmitter (see Figure 17) before all battery power is lost. When the batteries are replaced this Icon will disappear.



Figure 17: Low Battery Indicator.

IFC: The life span of the IFC batteries depends on various factors during a prolonged power outage: quality of the batteries used, the number of ignitions of the appliance, the number of changes to the room thermostat set point etc. When the IFC batteries are low, No “beep” will be emitted when it receives an On/Off command from the Transmitter. This is an alert for a low battery condition for the IFC. When the batteries are replaced the “beep” will be emitted from the Receiver when the ON/OFF Key is pressed (See INITIALIZING THE SYSTEM FOR THE FIRST TIME).

Battery Backup

In the event of a power outage the fireplace will still be able operate the main burners via a four AA battery backup. The battery backup is located behind the surround panel at the front bottom right of the fireplace. The plastic battery holder simply slides out from the steel sleeve attached to the fireplace cabinet. The battery holder can be fully removed from the fireplace by disconnecting the low voltage battery snap wires. Batteries should be checked annually to confirm they are still functional. Replace as needed.

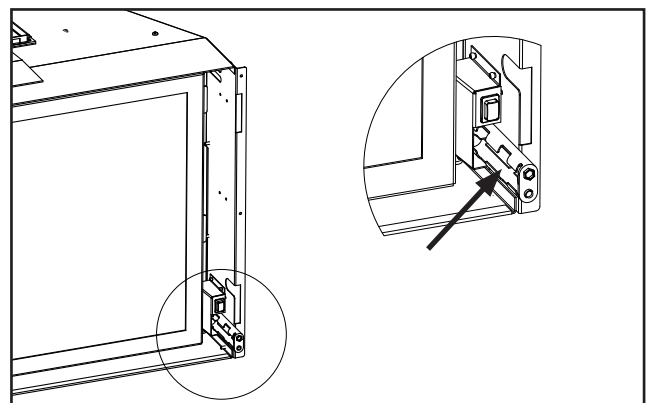

Figure 18: Backup Battery Location.

Note - Fan control and ember lights will not be operational when the fireplace is operating on battery backup.

OPERATING INSTRUCTIONS

Switching to Continuous Pilot Mode

When the fireplace is turned off press the mode key to index to the constant pilot (CPI) mode icon (see figure 5). Pressing the up arrow key will select Continuous Pilot Ignition (CPI) and pressing the down arrow key will return to IPI. Once a selection is made the IFC will beep once to confirm it had received the command. **NOTE: It is recommended to use the continuous pilot mode during the winter when the outside temperature is below 50°F (10°C) to keep the chimney properly heated for updraft during burner ignition.** Continuous pilot mode also keeps the firebox warm which eliminates both heat loss to cold air that is trapped inside the firebox as well as excessive exhaust vapour condensation on the door glass.

Note - The pilot will automatically extinguish if 7 days of continuous operation without any main burner use/activity is reached.

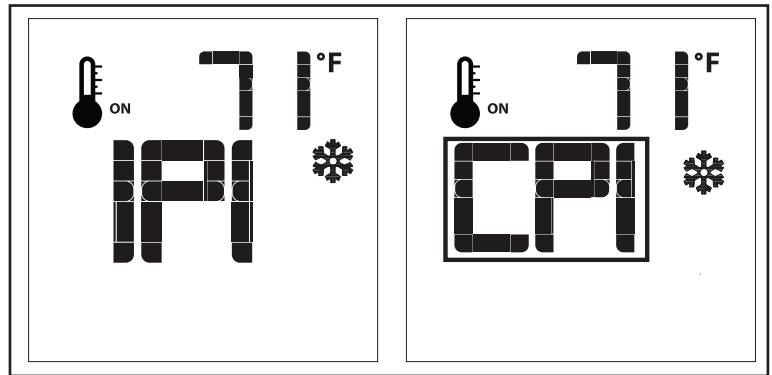

Figure 19: CPI Pilot Mode

WARNING: Fire Hazard. Can cause severe injury or death. The IFC causes ignition of the appliance. The appliance can turn on suddenly. Keep away from the appliance burner when operating the remote system.

WARNING: Shock Hazard. Can cause severe injury or death. This device is powered by line voltage. Do not try to repair this device. In no way is the enclosure to be tampered with or opened. Disconnect from line voltage before performing any maintenance.

CAUTION: Property Damage Hazard. Excessive heat can cause property damage. The appliance can stay lit for many hours. Turn off the appliance if it is not going to be attended for any length of time. Always place the Transmitter where children cannot reach it.

MAINTENANCE AND SERVICE

Warning: Failure to position the parts in accordance with this manual, or failure to use only parts specifically approved with this appliance, may result in property damage or personal injury.

At least once a year, run through the following procedures to ensure the system is clean and working properly. Check the burner to see if all the ports are clear and clean. Check the pilot to make sure it is not blocked by anything. The pilot flame should be blue with little or no yellow on the tips.

The venting system must be periodically examined; it is recommended the examination is done by a qualified person.

CLEANING THE PAINTED SURFACES:

Painted surfaces should be periodically wiped with a damp cloth when the unit is cool.

MAINTENANCE AND SERVICE

SURROUND/SCREEN REMOVAL:

WARNING: Do not attempt to remove the surround panel or screen until the unit has completely cooled.

Both the surround panel and screen assembly have four mounting hooks, two per side, that hold them onto the fireplace. To remove the screen, lift up and bring outward (Figure 20). The same process can be followed for the Surround Panel (Figure 21).

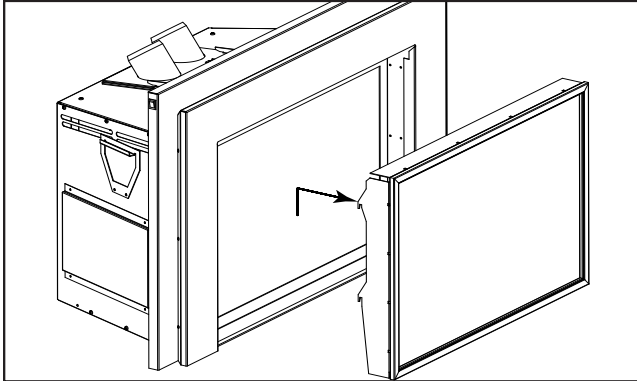

Figure 20: Door Spring Latch Locations

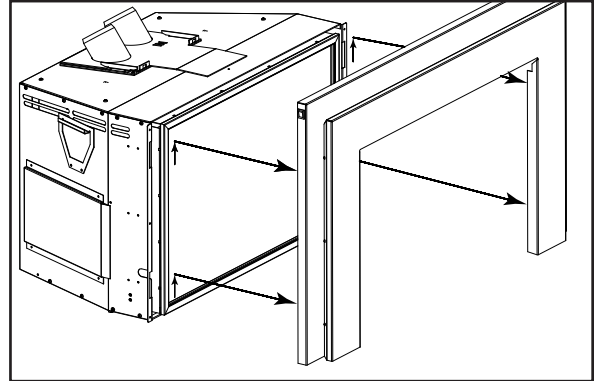

Figure 21: Door Spring Latch Locations

GLASS DOOR REMOVAL:

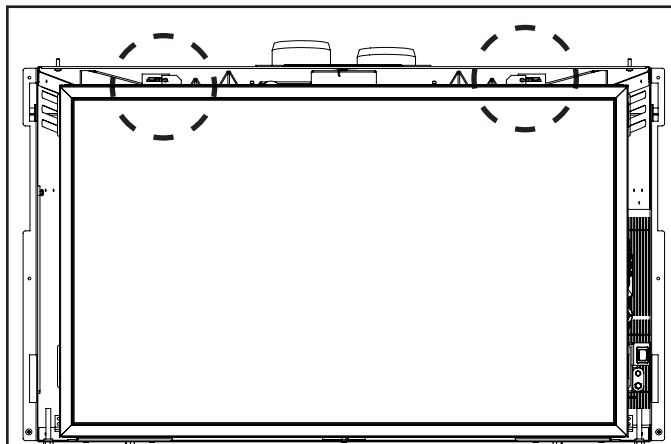

Figure 22: Door Spring Latch Locations

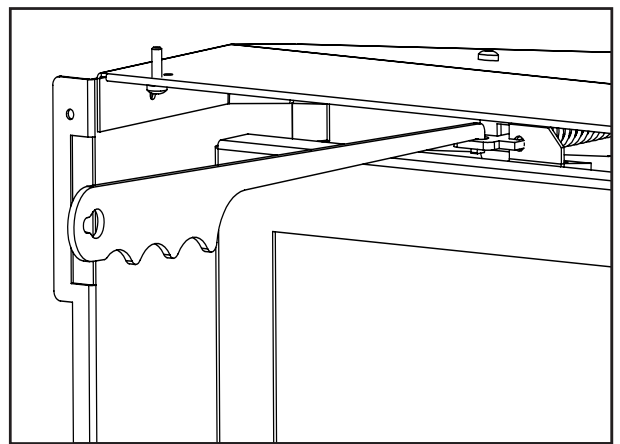

Figure 23: Door Latch Release.

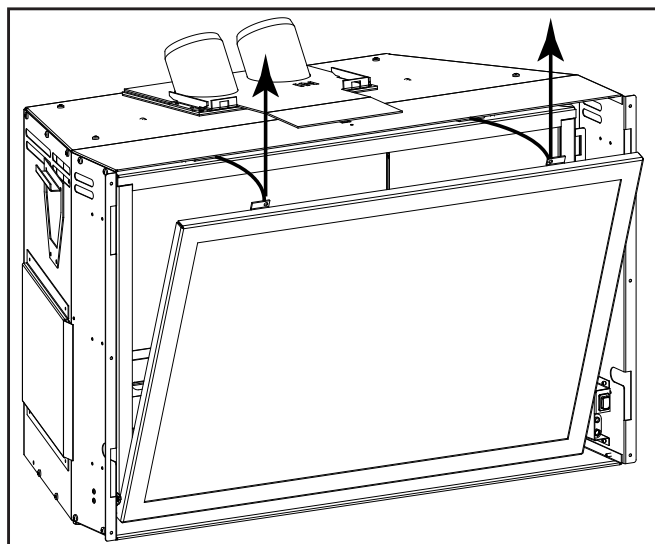

Figure 24: Door Removal

The glass door of the fireplace is retained at the top by two spring latches (Figure 22). Release the latches by placing the hooked end of the door tool in the hole on the door latch mechanism (Figure 23) and pulling the latch forward then out to the side. When the two (2) latches have been released, tilt the top of the door forward and lift up to remove the door (Figure 24). To install the glass door simply reverse the procedure.

Warning: Do not touch or attempt to remove the glass if the fireplace is not completely cool.
Never operate the fireplace with the glass removed.

CAUTION GLASS MAY SEPARATE FROM DOOR.

MAINTENANCE AND SERVICE

Warning: Failure to position the parts in accordance with this manual, or failure to use only parts specifically approved with this appliance, may result in property damage or personal injury.

At least once a year, run through the following procedures to ensure the system is clean and working properly. Check the burner to see if all the ports are clear and clean. Check the pilot to make sure it is not blocked by anything. The pilot flame should be blue with little or no yellow on the tips.

The venting system must be periodically examined; it is recommended the examination is done by a qualified person.

CLEANING THE GLASS:

When the fireplace is cool, remove the glass door. See MAINTENANCE AND SERVICE - GLASS DOOR REMOVAL. Check the gasket material on the back of the glass, making sure that it is attached and intact.

During a cold start up, condensation will form on the glass. This is a normal condition with all fireplaces. However, this condensation can allow dust and lint to cling to the glass surface. Initial paint curing of the appliance can leave a slight film on the glass. The glass will need cleaning after the fireplace has cooled off from the first burn and about two weeks after first burn. **Use a mild glass cleaner and a soft cloth. Abrasive cleaners will damage the glass and painted surfaces.** Depending on the amount of use, the glass should require cleaning no more than two or three times a season. **Do not clean the glass when it is hot.**

CLEANING THE FIREBOX:

Remove the logs carefully, as they are very fragile. Gently remove all the embers and rock wool and place on a paper towel. Vacuum the bottom of the firebox thoroughly. Carefully clean any dust off the logs and remove any lint from the burner and pilot. At this time, inspect the burner tube for cracking or severe warping. If a problem is suspected, contact the dealer. Check the logs for deterioration or large amounts of soot; a small amount on the logs is normal. Replace the logs and embers as in the SECONDARY INSTALLATION - LOG SET AND EMBER INSTALLATION section. If new/more embers and rock wool are required, contact your nearest ENVIRO dealer.

REPLACING THE GLASS:

The glass in the fireplace is a high temperature ceramic. If the glass is damaged in any way, a factory replacement is required (see PARTS LIST). Wear gloves when handling damaged glass door assembly to prevent personal injury. Do not operate with the glass front removed, cracked or broken. Removal and replacement of the glass from the door **must** be done by a licensed or qualified service person. **The glass must be purchased from an ENVIRO dealer. No substitute materials are allowed.** Remove the door (see page 15). The replacement glass will come with a new gasket installed. Remove any silicone remnants from the door. Apply high temperature silicone to the two vertical faces of the door and install the new piece of glass with gasket (be sure to maintain edge clearances). Apply even pressure to the glass to allow the silicone to adhere to the gasket material.

CHECK PILOT AND BURNER FLAMES:

Periodically do a visual check of the pilot flames. One flame should encompass the flame sensor and the other should burn over the burner ports (see page 31). Also check that the burner is operating correctly, refer to Venturi Adjustment section.

MAINTENANCE AND SERVICE

BURNER REMOVAL:

The burner may need to be removed for a few reasons, including cleaning under the burner, converting the unit to a different gas type, or to replace the burner altogether. Proceed only when the unit has completely cooled down.

1. Remove the glass door as shown in MAINTENANCE AND SERVICE - GLASS DOOR REMOVAL.
2. Carefully remove the log set and embers as shown in SECONDARY INSTALLATION - LOG SET INSTALLATION.

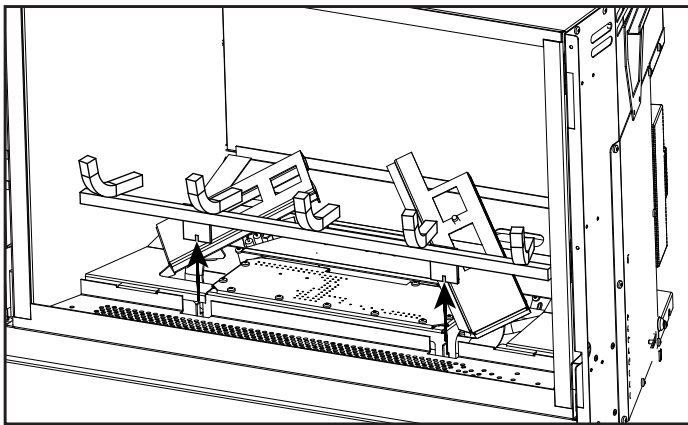

1. Remove the Log grate by lifting straight up.

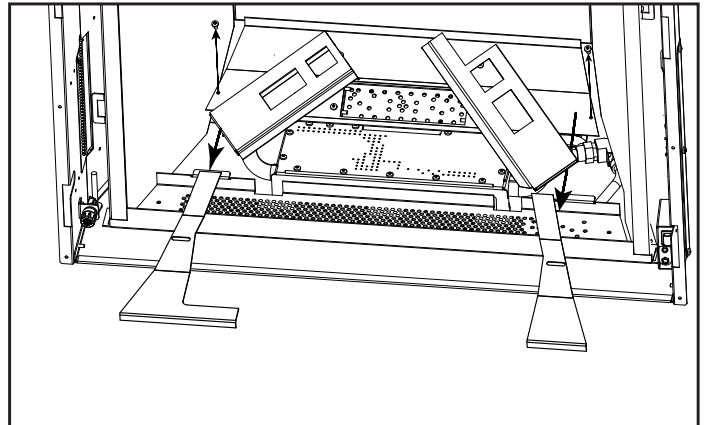

2. Remove the side air diverters by undoing the single T20 on each side and sliding the air diverters back out of the unit.

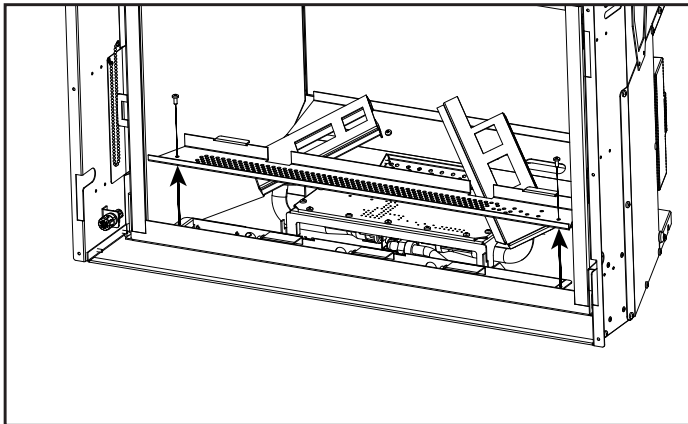

3. Remove the Front Ember Tray cover by undoing the two T20s on the outside edge of the tray.

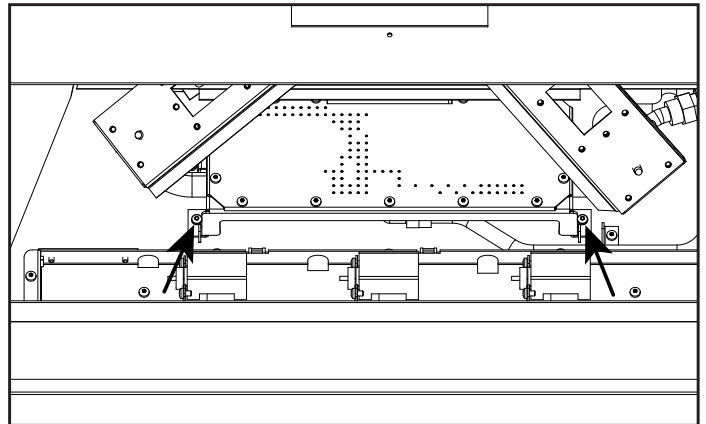

4. Undo the T20s holding the main burner.

MAINTENANCE AND SERVICE

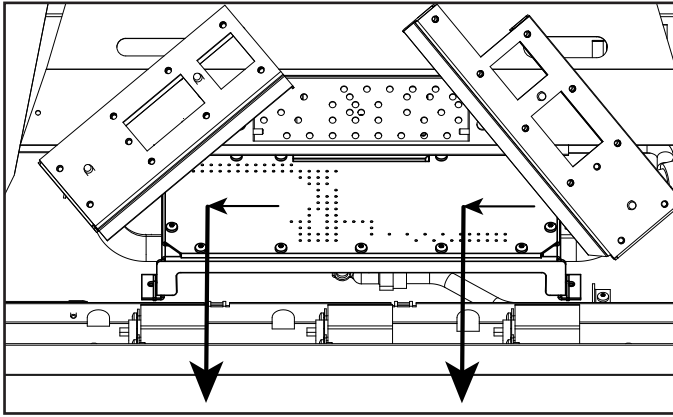

5. To remove the pan burner slide it to the left to disengage from the orifice and bring it back and out.

To re-install the burner repeat the steps above in reverse.

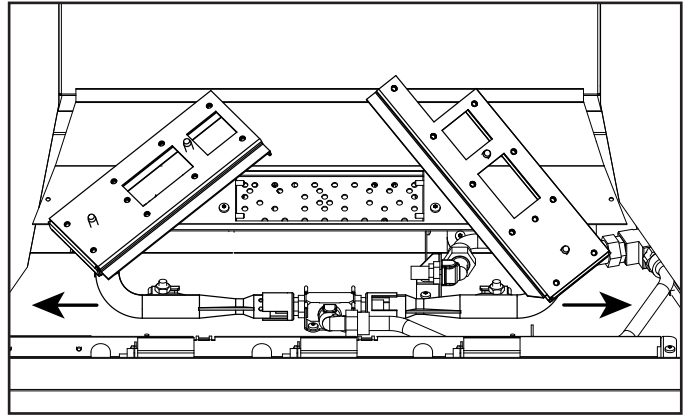

6. Loosen the 7/16" nuts and slide the burners outward the remove them.

AIR SHUTTERS:

The air shutters are located at the gas inlet of each burner and play a very important role in flame appearance, combustion quality and overall fireplace performance. The air shutters adjust how much air gets mixed with the gas before it ignites (called primary air). The air shutters are set at the factory but adjustments can be made to accommodate various climates, vent configurations and fuel conversions. If you cannot attain a healthy flame by making air shutter adjustments, you may have the incorrect restrictor setting or a venting issue. If the flame is very erratic, fast moving, and low then increase the restriction. If the flame is very tall, lazy, and dirty or transparent then decrease the restriction. More details can be found in the venting section of this manual.

Normal Operation Note - From a cold start, flames can take up to 15 minutes to achieve a desirable healthy colour and appearance.

Caution: Wear heat resistant gloves when making adjustments to the air shutters after fireplace has been in operation.

Tool Required: A #2 Phillips screwdriver is needed to adjust the burner air shutters set screw.

Elevated Burners - For both natural gas (NG) and propane (LP) fuels, the air shutters on the left and right elevated burners should be in the range of 1/8"-3/16" open for the majority of installations. LP should be 5/16" - fully open.

Pan Burner - For NG fuel the burner pan shutter should be in the range of 1/16"-1/8" open. For LP fuel the burner pan shutter should be 5/16" - fully open. If burner pan flames are too tall, on either fuel, the shutter can be opened more.

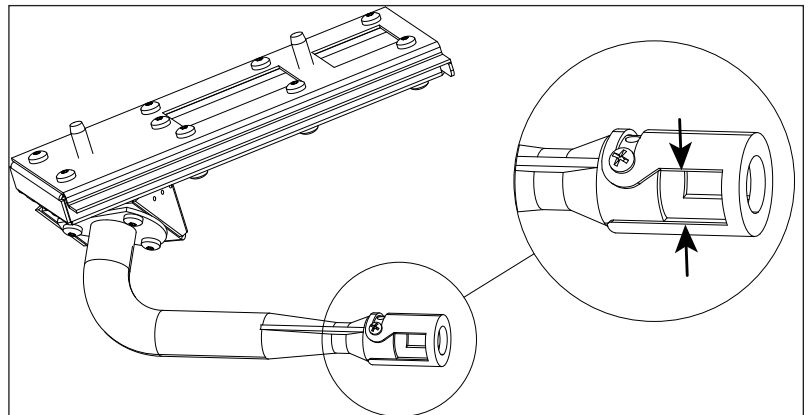

Figure 25: Elevated Burner - Airshutter

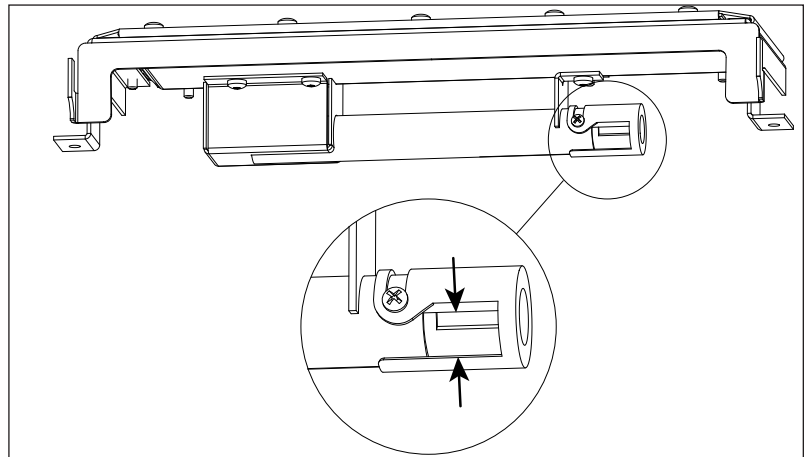

Figure 26: Pan Burner - Airshutter

MAINTENANCE AND SERVICE

EMBER LIGHTS - BULB REPLACEMENT:

1. Disconnect electrical power to the unit.
2. Remove log set, side air diverters, and log grate (see MAINTENANCE AND SERVICE - BURNER AND LOG GRATE REMOVAL). The 3 burners can remain in place for ember light replacement.

Front Ember Tray Removal

1. Remove all glass and coal media from the front ember tray.
2. Using a Torx T20 screwdriver, remove the two (2) retaining screws from the front ember tray. Lift the ember tray up and out of the fireplace.
3. Remove the two (2) T20 screws holding the light tray to the firebox.
4. Remove the bulb cover of the burnt out bulb by undoing the T20 at the back of the light tray.
5. The front ember lights will now be accessible. There are three (3) halogen bulbs.

Rear Ember Tray Removal

1. Remove all glass and from the rear ember tray.
2. Using a Torx T20 screwdriver, remove the retaining screw from the rear ember tray.
3. Lift the ember tray out of the fireplace. The rear ember lights will now be accessible. There are two (2) halogen bulbs.

Halogen Bulb Replacement

4. Wear cotton gloves when replacing halogen bulbs. Grab bulb firmly at the base and pull straight out to remove; replace bulb as necessary. Grab new bulb by the foam sleeve - it is vital that your bare fingers do not contact the bulb. **The oils from your fingers will greatly reduce the life-span of the bulb.**

Halogen Bulb specifications:

GY6.35 Bi-Pin Base 120V, 35W

Enviro Part #: 50-3291

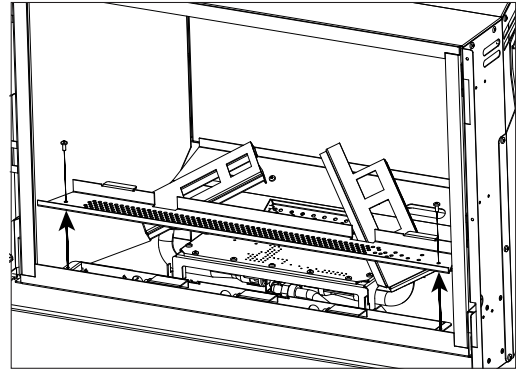

Figure 27: Front Ember Tray Removal.

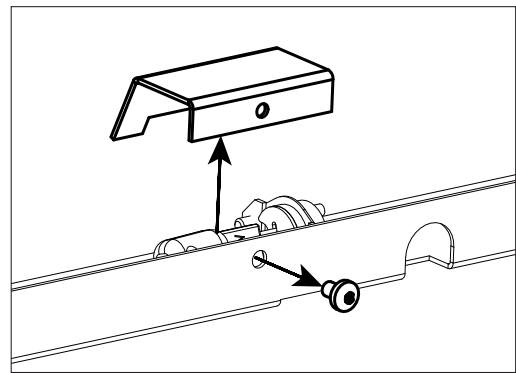

Figure 28: Bulb Cover Removal

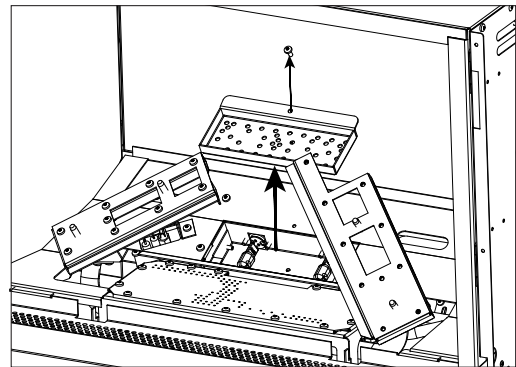

Figure 29: Rear Ember Tray Removal.

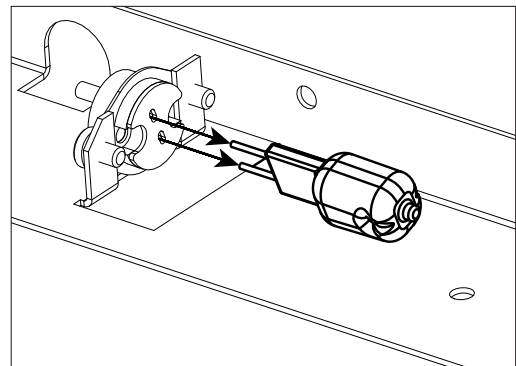

Figure 30: Light Bulb Removal

MAINTENANCE AND SERVICE

FAN REPLACEMENT

1. Disconnect the electrical power from the unit before starting any work.
2. Remove the six (6) T20 screws that secure the fan assembly to the back of the fireplace (Figure 31)
3. Detach the fan from the rubber mounts and remove the fan mount from the back of the fan by loosening the three (3) T20 screws holding it in place (Figure 32).
4. When you receive your new fan, you will need to rotate the fan motor 90 degrees for proper installation. To do this:
 - Twist the motor counterclockwise until you feel it click out of place (Figure 33).
 - Pull the motor slightly and rotate it 90 degrees counterclockwise into the next set of slots on the blade assembly (Figure 34).
 - Once positioned correctly, push the motor into the slots and turn it clockwise to lock it into place (Figure 35).
5. Reassemble the unit in the reverse order of disassembly.

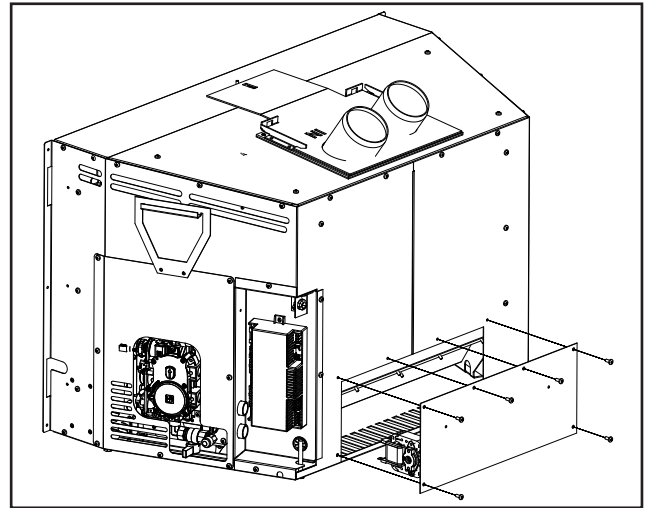

Figure 31: Fan Assembly Removal

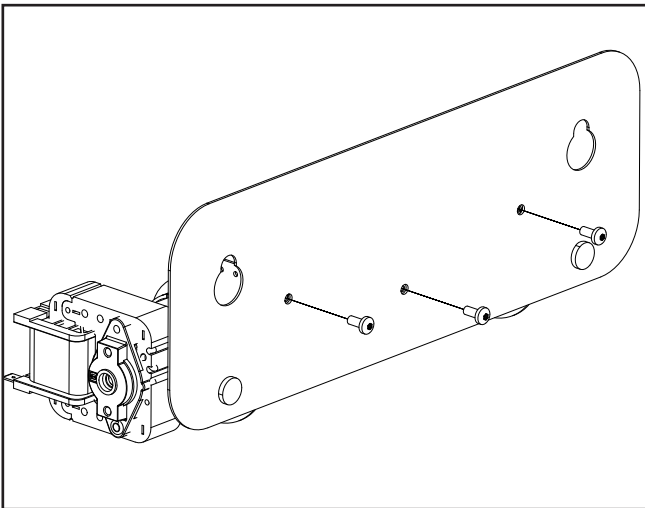

Figure 32: Fan Removal

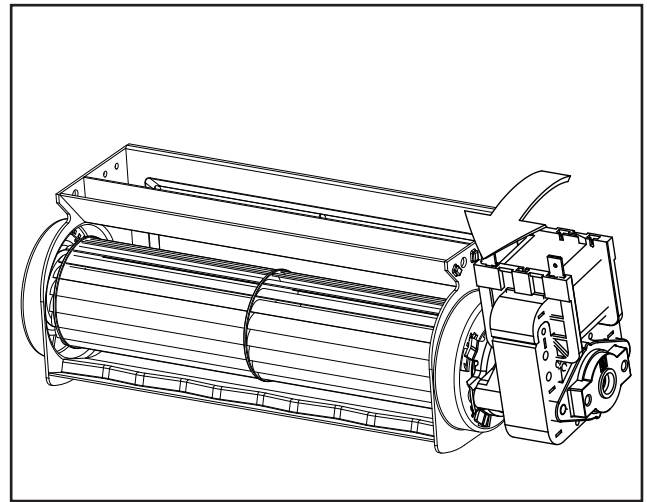

Figure 33: Unlocking the motor

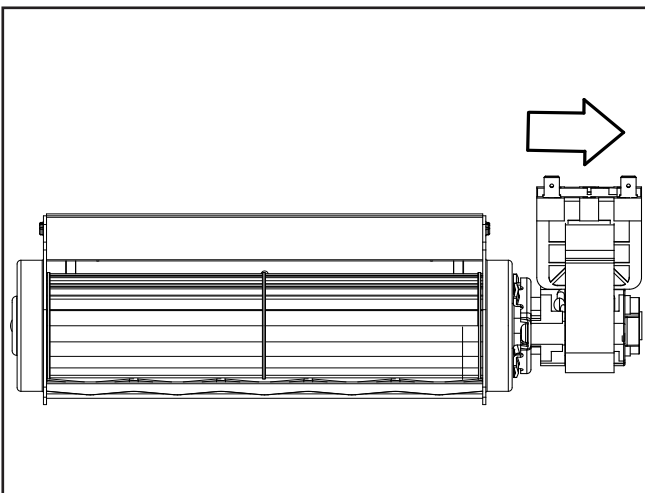

Figure 34: Pulling out the motor

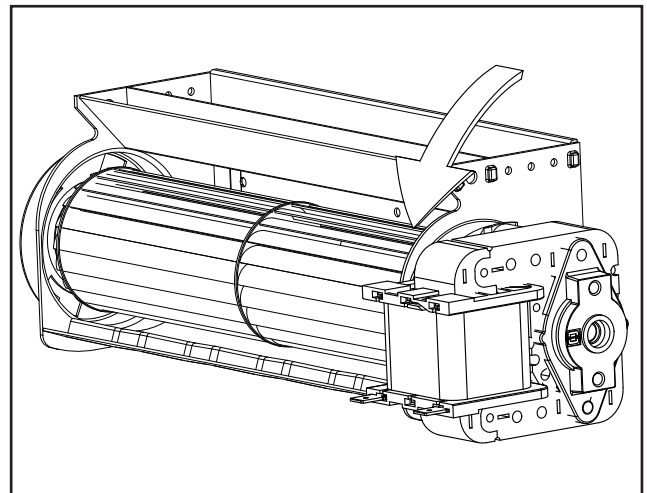

Figure 35: Final Motor Position

FUEL CONVERSION

TO BE INSTALLED BY A QUALIFIED SERVICE AGENCY ONLY

Please read and understand these instructions before installing.

Warning: This conversion kit shall be installed by a qualified service agency in accordance with the manufacturer's instructions and all applicable codes and requirements of the authority having jurisdiction. If the information in these instructions is not followed exactly, a fire, explosion or production of carbon monoxide may result causing property damage, personal injury or loss of life. The qualified service agency is responsible for the proper installation of this kit. The installation is not proper or complete until the operation of the converted appliance is checked as specified in the manufacturer's instructions supplied with the kit.

Kit Parts List for Ri30 Model:

- 1 - Burner Orifice LP [2 x #58, 1 x #63]
- 2 - LP Pilot Orifice
- 3 - LP Log Sapters x 4
- 4 - LP Stepper Motor w/ Hardware & Label
- 5 - Conversion Labels

Tools Required for Fuel Conversion:

- 1/2" wrench or socket (deep preferably)
- 7/16" wrench or socket
- Cordless drill with long Torx T20 driver bit

Carefully inspect all parts supplied with this conversion kit. If any parts have been damaged or are missing, contact your dealer or distributor to have them replaced before starting this installation.

CONVERSION KIT INSTALLATION:

1. **Disconnect the gas supply completely as well as any electrical power source before proceeding.**
2. Remove the surround, glass door, log grate and burners (see ANNUAL MAINTENANCE, MAINTENANCE AND SERVICE sections of this manual).
3. Remove the four (4) T20 screws holding the back tray and remove the back tray to gain access to the pilot (Figure 36).
4. Convert the existing pilot orifice with the one provided with the unit (see Figure 37) using a 7/16" wrench. Fully unscrew and remove the pilot head and replace the orifice insert, bell end down. Re-install and tighten the pilot, if the head does not reach proper orientation in the snug position then contact your Enviro dealer.
5. Convert the burner pan orifices with the one provided in this kit using a ratchet and 1/2" socket (Figure 38). There are two #58 orifices that are for the elevated burners and one #63 orifice that is used for the pan burner. The markings can be found on the side of each orifice (See figure 39). For specific instal locations of each orifice see see Figure 34.

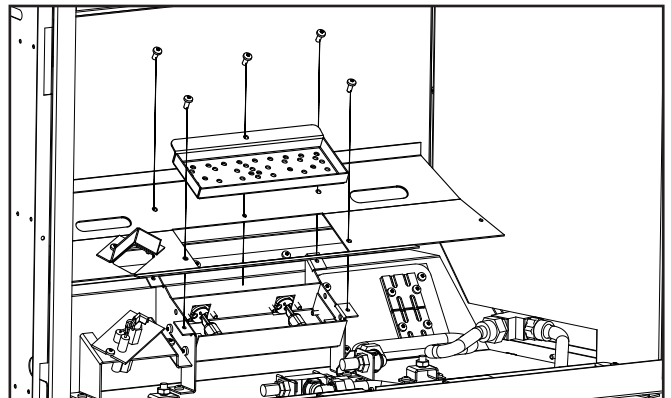

Figure 36: Rear Tray Removal

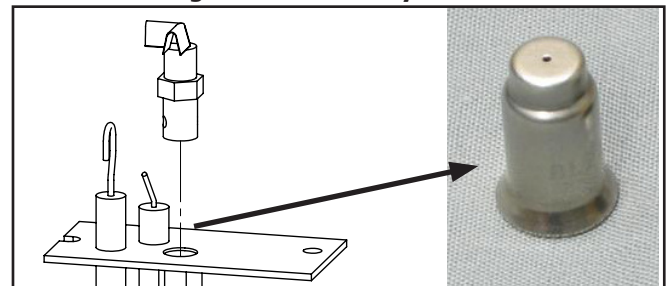

Figure 37: Pilot Orifice (not to scale)

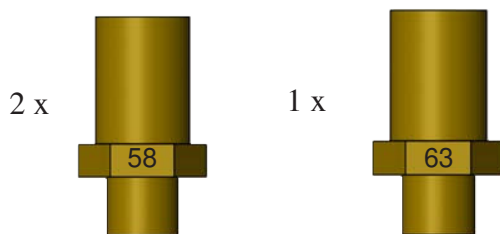

Figure 38: Orifice Markings

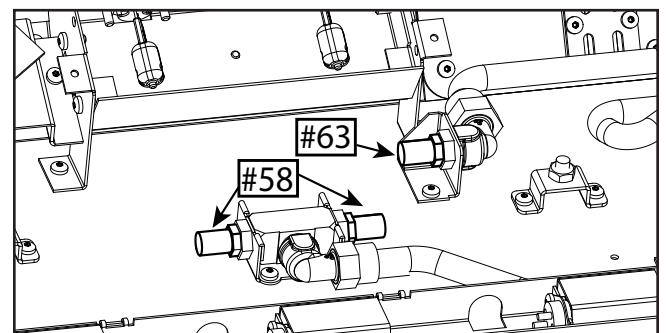

Figure 39: Burner Orifice Locations

FUEL CONVERSION

6. Before reinstalling the burners adjust the venturi shutters on the burners (see page 18).
7. Reinstall the burners, light trays, and air diverters.
8. Install the LP Logs Spacers onto each of the log pins on the burners as shown in Figures 40 and 41.
9. To gain access to the valve remove the valve cover by unscrewing the nine (9) T20 screws on the right side of the unit (see Figure 42)
10. Convert the SIT gas valve (Figure 43):

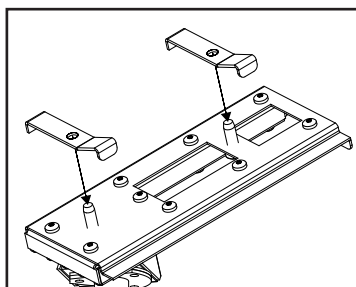

Figure 40: Left Burner LP Conversion

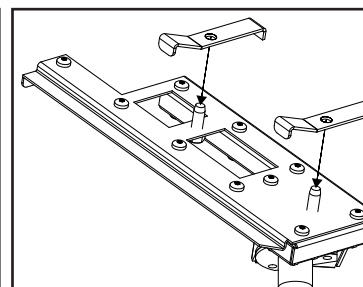

Figure 41: Right Burner LP Conversion

- a) Locate the gas valve directly underneath the front of the firebox and remove the existing stepper motor using a T20 screwdriver [A & B].
- b) Remove the rubber diaphragm and spring [C] within; **DO NOT REUSE**.
- c) Install the new stepper motor with integrated diaphragm assembly [D & E] using the longer T20 screws supplied [F].
- d) Adhere the supplied SIT conversion label [G] to the valve body.
- e) Plug the new stepper motor into the X6 port of the IFC.

11. Reinstall the burners, log grate, burner pan media, logs set, glass door and surround (see ANNUAL MAINTENANCE, MAINTENANCE AND SERVICE sections of this manual).
12. Purge any air from gas line and reconnect to unit.
13. Use a small brush and apply a warm soapy water solution to all gas connections. If a gas leak is present, bubbling will occur. Gas leaks can be repaired by using a gas approved pipe thread sealant. **WARNING: NEVER USE AN OPEN FLAME WHEN TESTING FOR GAS LEAKS.**
14. Reconnect electrical power to the unit.

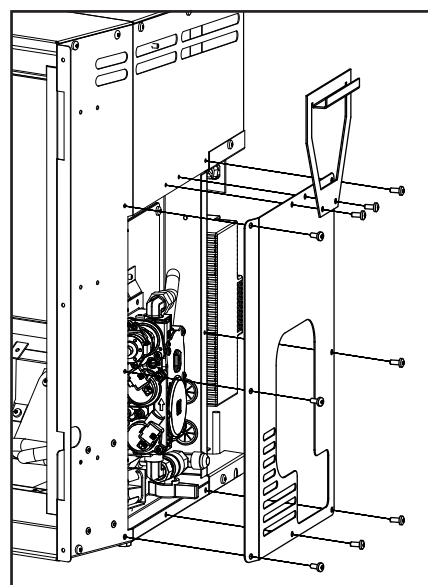

Figure 42: Valve Cover Removal

15. Light the pilot and recheck for leaks in the aluminum pilot line. If a leak is evident, contact your ENVIRO dealer for a pilot line replacement. **WARNING: DO NOT ATTEMPT TO FIX THIS LINE, IT MUST BE REPLACED IF DAMAGED.** The pilot should properly cover the flame sensor. See MAINTENANCE AND SERVICE - PILOT LIGHT SECTION of this manual.
16. Start the main burner and verify full range of adjustment using the remote. Confirm the inlet and manifold gas pressures are within the acceptable range using a manometer (see INITIAL INSTALLATION - GAS LINE CONNECTION AND TESTING). If this unit has been installed at an altitude higher than 2000ft (610m) it is required to de-rate the unit accordingly.

17. **MAKE SURE** that the conversion labels provided are installed on or close to the rating label to signify that the unit has been converted to a different fuel type.
In the USA: The appliance may be installed at higher altitudes. Please refer to your American Gas Association guidelines which state: the sea level rated input of Gas Designed Appliances installed at elevations above 2000 (610 m) feet is to be reduced 4% for each 1000 feet (305 m) above sea level. Refer also to local authorities or codes which have jurisdiction in your area regarding the de-rate guidelines.

In Canada: When the appliance is installed at elevations above 4500 feet (1372 m), the certified high altitude rating shall be reduced at the rate of 4% for each additional 1000 feet (305 m).

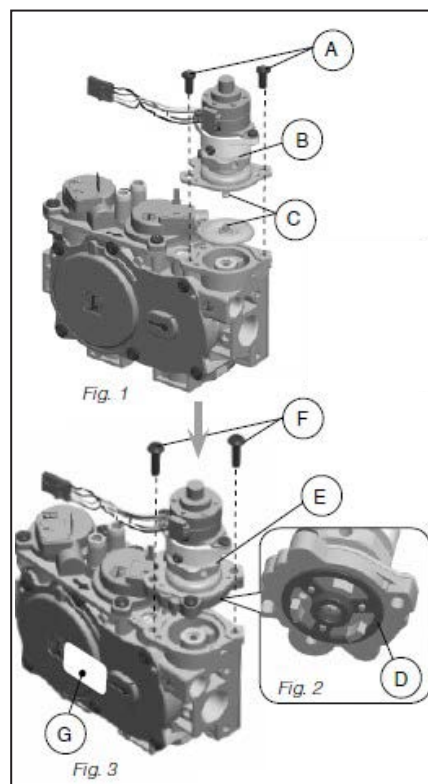

Figure 43: SIT Valve Conversion

INITIAL INSTALLATION

WARNING: Operation of this heater when not connected to a properly installed and maintained venting system can result in carbon monoxide (CO) poisoning and possible death.

CLEARANCES TO COMBUSTIBLES:

Maintain sufficient clearances for operation, service and maintenance.

- A minimum distance of 6" (152 mm) is required from the edge of the firebox door to the sidewalls.
- Minimum clearance for any combustible facing is 32" (813 mm) from the bottom of the unit.
- A 4" (102 mm) mantel can be mounted at a minimum height of 36" (91cm) from the bottom of unit. (See Figure 44)
- No floor protection is required in front of the unit.
- Unit may be installed with combustible material underneath as long as it is raised 1/2" (13 mm) off the floor.
- Minimum ceiling clearance is 56" (142 cm) from bottom of unit.

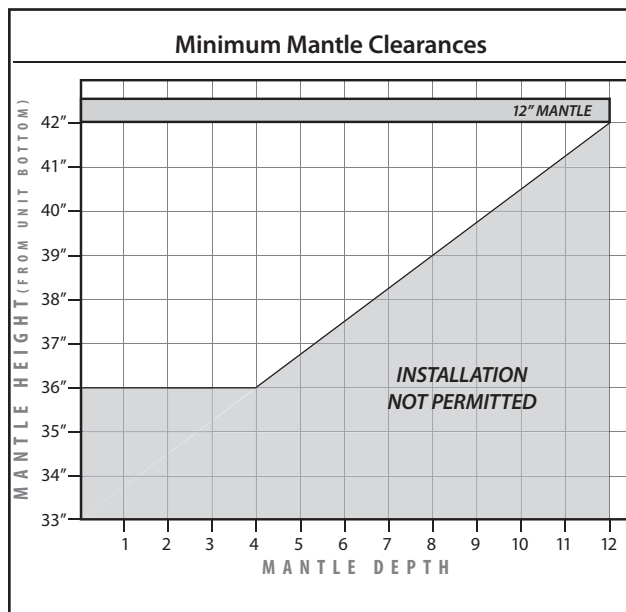

Figure 44: Mantle Clearances.

MINIMUM FIREPLACE SIZE:

Table 5: Minimum dimensions of fireplace for Ri30 to be installed into.

	Width At Front	Width At Back	Height	Depth
Fireplace Dimensions	30" (762 mm)	20" (508 mm)	20" (508 mm)	15" (406 mm)

NOTE: Space must be provided for gas line on right side of unit for servicing purposes.

NON-COMBUSTIBLE BUILD OUT:

The Ri30 may be installed and vented into any solid fuel fireplace that has been installed in accordance with the National, Provincial/State and local building codes and has been constructed of noncombustible materials. Before starting, refer to please reference the information in Table 7 and Figure 45.

Additionally should extra installation depth be required, the existing fireplace may be re-faced with a build out in front, constructed completely of non-combustible framing and finishing material (see Figure 45). The build out must be constructed and sealed to prevent any heat from collecting in-between the existing fireplace and the finishing material. Prior to constructing the build out it is important to know the overall size of the selected surround panel. For ease of installation and servicing it is recommended to only have a small overlap from the finished opening. Refer to the minimum fireplace size (table 5) to compare with the selected surround panel. The flex venting is permitted to have smooth sweeping, slight angle bends but must not be kinked in any way.

IMPORTANT - Contact your local dealer for further information prior to construction and installation.

INITIAL INSTALLATION

QUALIFIED INSTALLERS ONLY

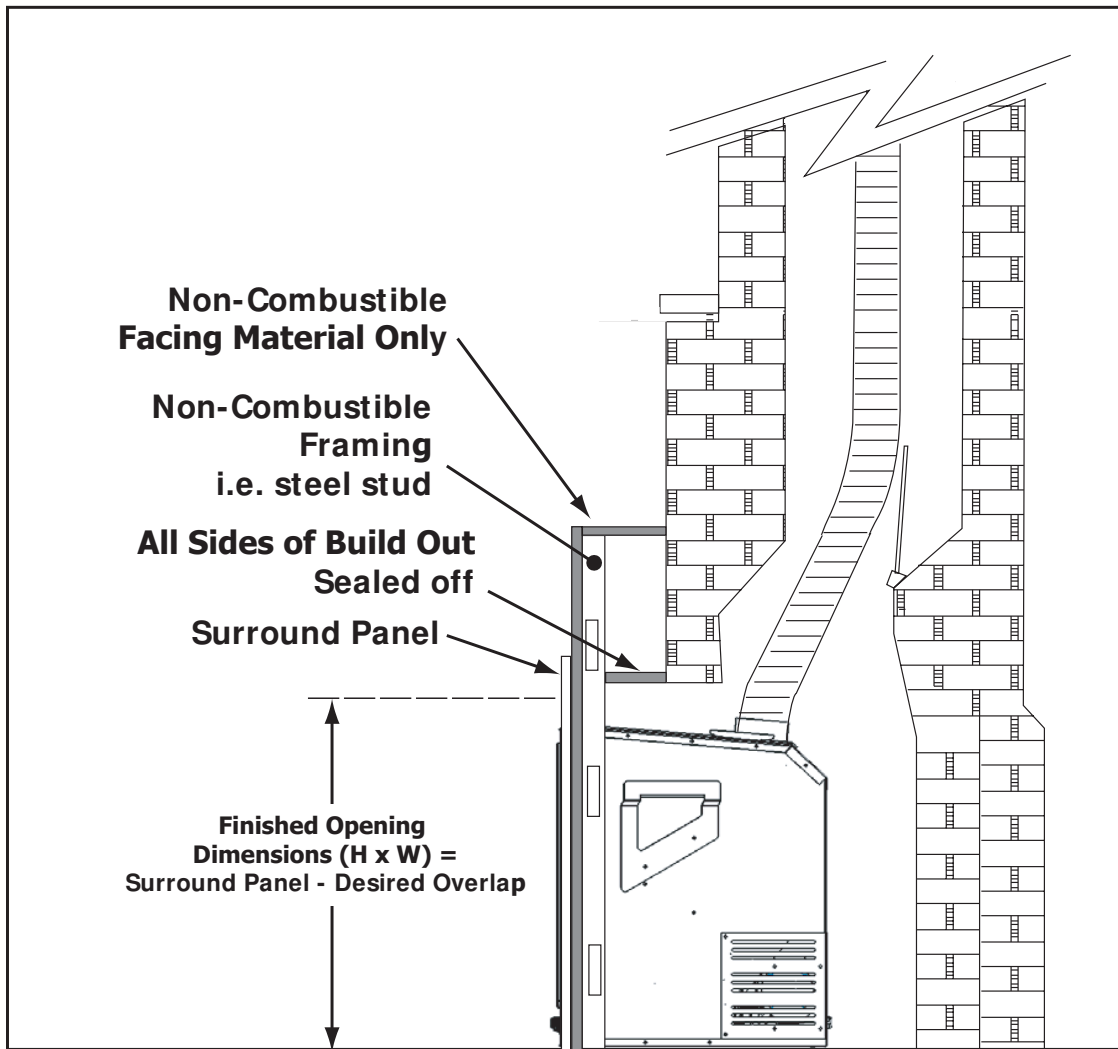

Figure 45: Installation with a non-combustible build out.

VENTING:

WARNING: This appliance has been designed to draw room air for proper heat circulation from the sides and bottom of the unit, and out the top front. Blocking or modifying these openings in any way can create hazardous situations.

The vent length for the Ri30 must be between 10ft (3.05 m) and 40ft (12.2 m).

The Ri30 intake and exhaust must be connected to 3" dia. flexible venting, made of either aluminum or stainless steel, leading into a vertical termination cap. The flue collars of this model will fit inside of a standard 3" vent and must be fastened directly to the vent with three screws. The exhaust vent and air intake are both located on the top of the unit.

Check periodically that the vents are unrestricted. Also ensure that all direct vent pipes have been properly sealed and installed after routine inspection or cleaning. The air intake and exhaust pipes must be installed in the correct locations on the top of the Ri30.

INITIAL INSTALLATION

QUALIFIED INSTALLERS ONLY

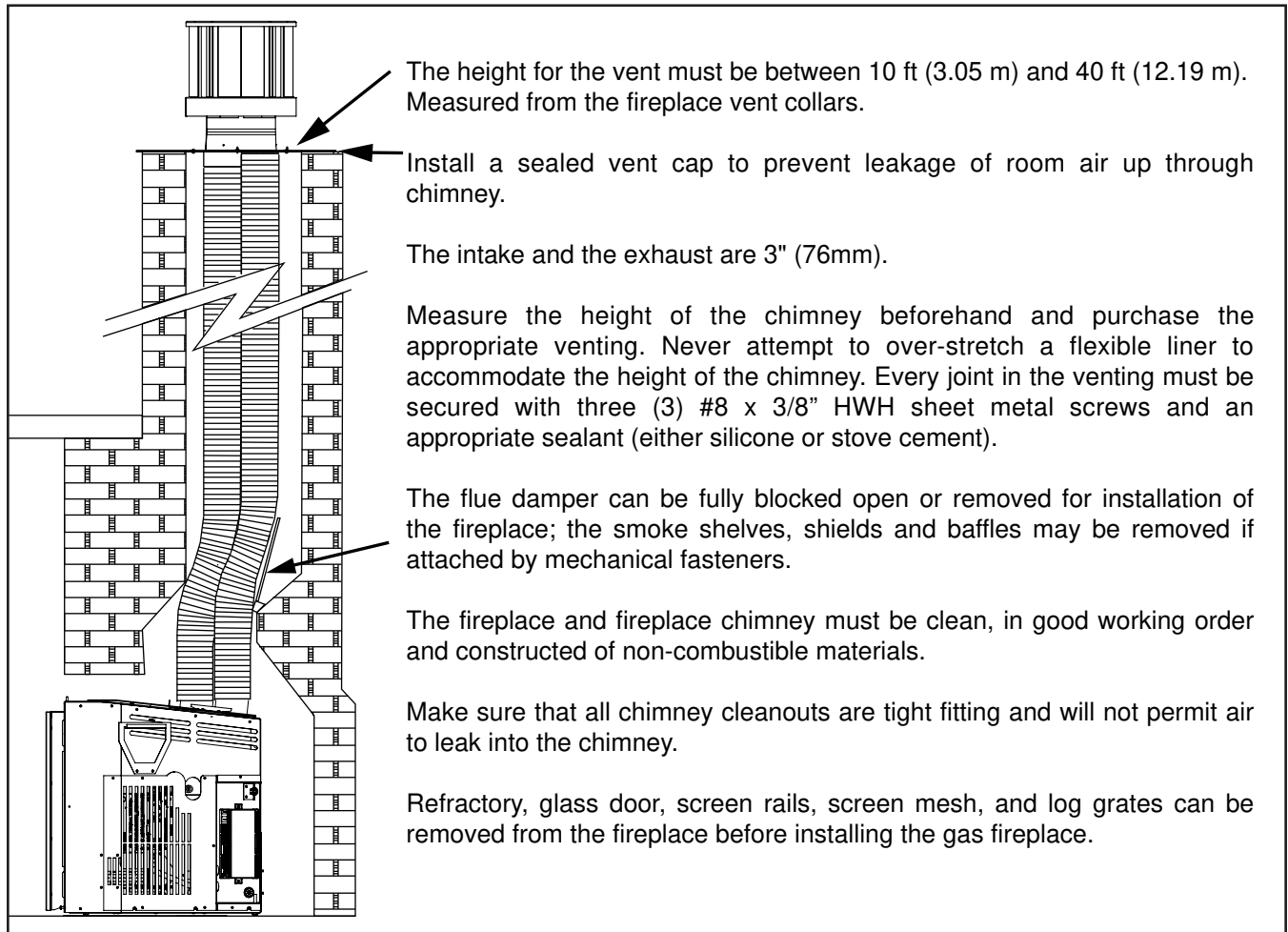

Figure 46: Installation of Ri30

The **ENVIRO** Ri30 may be installed and vented into any solid fuel fireplace that has been installed in accordance with the National, Provincial/State and local building codes and has been constructed of non-combustible materials. Please reference the information in Table 7 and Figure 46.

An approved chimney liner and rain cap must be used. A throat connector or flashing **must** be installed to ensure a tight seal, top performance, safety and efficiency. Carefully follow the manufacturer's instructions that accompany the chimney liner kit. Use double walled aluminum or stainless steel flex vent from any of the approved brands listed in table 8. If necessary, remove the vent collar plate from the top of the insert and connect it securely to the liner with sheet metal screws.

Check for any tears in the liner at this point. **IMPORTANT:** The screws that hold the vent collar plate in its approved position must be installed.

NOTE: If the Ri30 unit is pulled out of its installation, and the vent air intake system is disconnected for any reason, ensure that the vent-air intake pipes are re-sealed with high-temperature sealant and reconnected with three (3) sheet metal screws evenly spaced.

INITIAL INSTALLATION

QUALIFIED INSTALLERS ONLY

EXHAUST RESTRICTOR:

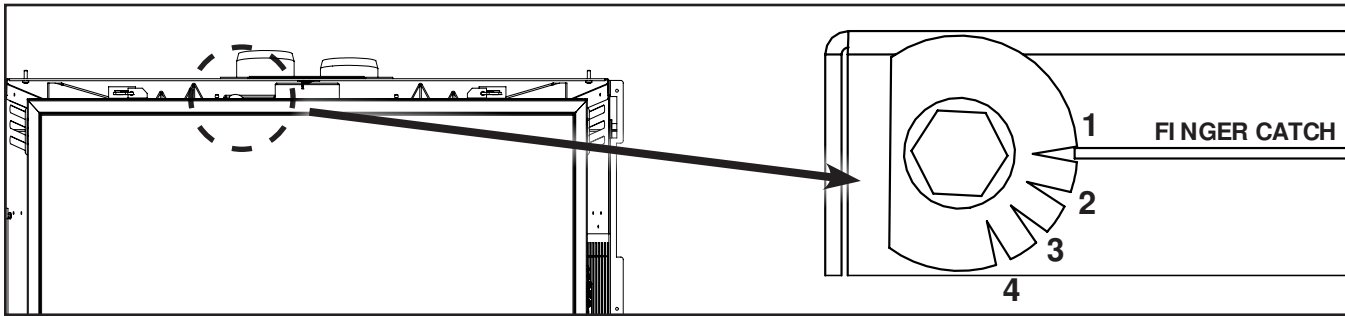

Figure 47: Exhaust Restrictor

This fireplace has an internal exhaust restrictor that can be adjusted externally while the fireplace is in operation. Depending on the length of venting required for installation, this may need to be adjusted. The restrictor is accessed from the front of the fireplace through the discharge opening as shown above. Using a 3/8" socket on a 10" long extension, rotate the restrictor COUNTER-CLOCKWISE until the required setting is in line with the finger catch. Refer to Table 6 for the required restrictor setting.

Note: The restrictor is set to setting # 1 from the factory.

Table 6: Restrictor Settings

Vent Length	Restrictor Setting
10'-20' (3.05-6.1m)	1
20'-30' (6.1-9.1m)	2
30'-40' (9.1-12.2m)	3

INSTALLING THE Ri30:

- Remove the crate and packaging from the appliance and check to make sure there is no damage. Carefully check the glass door. Do not use the unit if it is damaged. In the event damage is found, please report it to your dealer as soon as possible.
- Carefully clean the fireplace and flue before installing the stove. Failure to do so may result in fumes or soot being blown into the room and may cause a fire leading to death or serious injury.

INSTALLATION INSTRUCTIONS:

1. Plan your installation and clearances to combustibles. The Ri30 may be installed and vented into any solid fuel fireplace that has been installed in accordance with the National, Provincial/State and local building codes and has been constructed of non-combustible materials. Also refer CLEARANCES TO COMBUSTIBLES section.
2. Remove door. See MAINTENANCE AND SERVICE - GLASS DOOR REMOVAL.

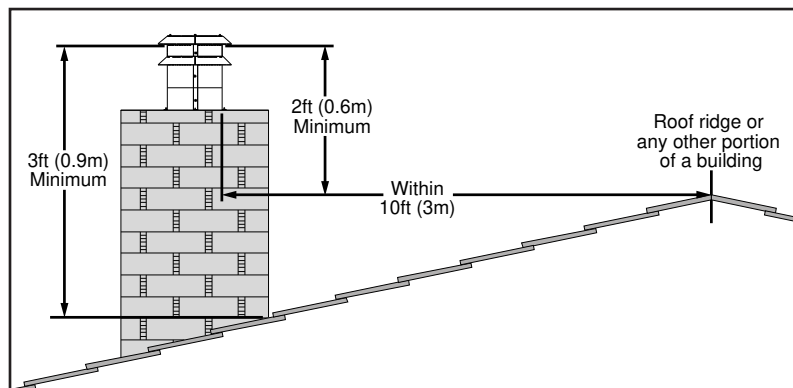

Figure 48: Roof Clearances.

3. Remove packaged log set and all wrapping material from the stove. Remove wrapping material from the log set and check for any damage. If damage is observed, do not use unit and contact your local dealer.

INITIAL INSTALLATION

QUALIFIED INSTALLERS ONLY

Table 7: Vent termination clearances

Minimum Clearance*	Description
3 ft (0.9 m)	Clearance above the highest point where it passes through a roof surface, refer to Figure 23.
24 in (0.6 m)	Clearance above a roof ridge, any other portion of a building, or any other obstruction within a horizontal distance of 10 feet (3 m), refer to Figure 23.
6 ft (1.83 m)	Clearance to mechanical air supply inlet.
3ft (0.9m)	Clearance to each side of center line extended above meter/regulator assembly.
6 ft (1.83 m)	Radial clearance around service regulator vent outlet.
12 in (30 cm)	Clearance above grade, verandah, porch, deck, or balcony.
3 ft (0.9 m)	Clearance to a building opening or combustion air inlet of another appliance, except with the approval of the authority having jurisdiction for the following reduced clearances.
9 in (0.23 m)	Exception for inputs up to and including 50,000 Btu/h (15kW)
12 in (0.3 m)	Exception for inputs exceeding 50,000 Btu/h (15kW) but not exceeding 100,000 Btu/h (30kW)

*Clearances are in accordance with local installation codes and the requirements of the gas supplier

- Check that the chimney clean outs fit properly. The flue damper must be fully blocked open or removed for installation of the Ri30; the smoke shelves, shields and baffles may be removed if attached by mechanical fasteners.
- Stretch the Ø3" (76mm) flex vent liners to the length needed to ensure they can be easily connected to the vent terminals.
- Install the flex pipe assembly up through the chimney, ensure that the pipe slides through far enough to connect onto the vent cap. Refer to table 8 to confirm the vent cap is approved for use.
- Most vent caps can be installed onto chimneys with flue openings up to 16" (406mm) x 16" (406mm) when the actual flashing is 16" x 16" or larger. If the chimney is smaller, the flashing should be trimmed down and folded over.
- Apply a bead of stove cement sealant to the Ø3" (76mm) pipe of the exhaust vent terminal. Slide the flex liner onto the vent terminal and secure with three (3) sheet metal screws evenly spaced.
- Place a bead of high temperature silicone on the intake collar of the vent terminal. Slide the Ø3" (76mm) flex intake liner over the collar, secure the flex liner with three (3) sheet metal screws evenly spaced. Secure the vent terminal to the chimney using adequate sealant, and according to local building codes.

Table 8: Approved Terminations & other parts

	ICC EXCELDirect	M&G DirectVent Pro	Z-Flex
Vertical Termination	TM-SVT*	46DVA-VCH*	See Liner Kit
	TM-IVT		
High-Wind Shield†	TM-SVTS	46DVA-VWG	
Flashing	TF-MFR	46DVA-GK	See Liner Kit
Co-Linear Adapter	TM-CTA		
35' Liner Kit	TM-ALK	46DVA-CL33	2DVI335X
35' Flex Pipe (1 pce.)	TC-øAL35	3DFA-35	

*Requires co-linear adapter

†Required when installed with minimum vent length

INITIAL INSTALLATION

QUALIFIED INSTALLERS ONLY

10. If the fireplace opening is lower than 24" (610 mm), remove the vent collar plate from the top of the insert by unlatching the hook located on the center top of the stove above the door opening (see Figure 49). Slide the collar plate backwards. Properly secure the vent collar plate to the flexible vent pipe liner(s) previously installed in the chimney. Be careful not to over-stretch the liner(s).
11. Apply a bead of stove cement sealant to the top section of the Ø3" (76mm) exhaust vent collar plate. Slide the Ø3" (76mm) flex vent over the flue collar and secure with three (3) sheet metal screws evenly spaced.
12. Place a bead of high temperature silicone on the intake collar of the fireplace, slide the Ø3" (76mm) flex intake liner over the collar, secure the flex liner with three (3) sheet metal screws evenly spaced.
13. Place the unit part way into the fireplace. Connect the gas line to the 3/8" NPT fitting on the right side of the unit using locally approved methods (see INITIAL INSTALLATION - GAS LINE CONNECTION). Route the power cord so it can be connected to the power supply.
14. As you push the unit into its final position in the fireplace, if the vent collar plate was removed, reinstall it on the stove by pulling it into the brackets on top using the supplied tool and latch it back in place (shown in Figure 50).
15. Adjust the levelling legs to ensure the unit is level and high enough if a base shelf and/or riser is to be installed. There are four levelling legs on the bottom of the unit (shown in Figure 51).

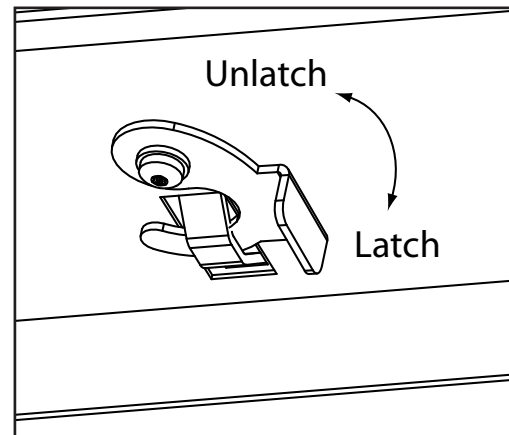

Figure 49: Vent Collar Plate Latch.

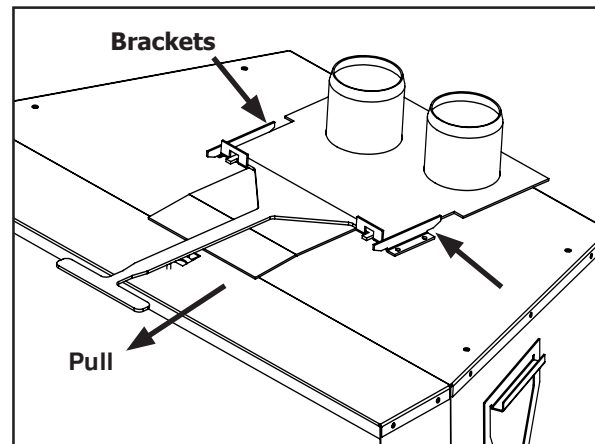

Figure 50: Vent Collar Plate Tool.

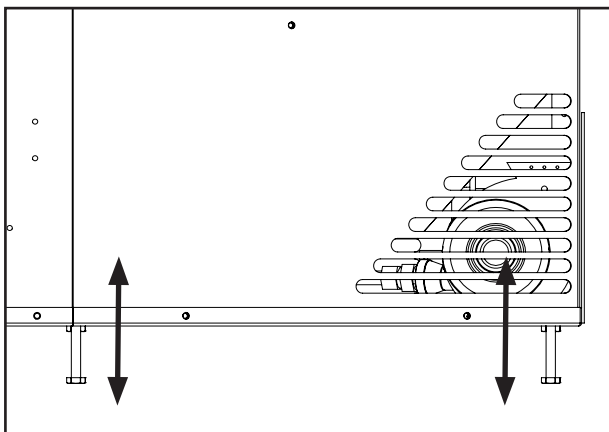

Figure 51: Levelling Legs Position.

INITIAL INSTALLATION

QUALIFIED INSTALLERS ONLY

ZERO CLEARANCE (ZC) FIREPLACE INSTALLATION:

The metal floor of the ZC solid fuel firebox can be removed to allow the installation of the insert. THE CLEARANCE TO COMBUSTIBLE MATERIAL UNDER THE INSERT IS 1/2" (13 mm). YOU MUST RAISE THE INSERT A MINIMUM OF 1/2" (13 mm) IF THE UNIT IS TO BE INSTALLED ON COMBUSTIBLE MATERIAL. The optional Base Shelf and Riser are recommended to fill the space under the unit once raised. The sidewalls and top structure of the solid fuel firebox cannot be altered with the exception of: removal of dampers, removal of smoke shelf or baffle, removal of ember catches, removal of log grate, removal of viewing screen/curtain, and removal of doors. THE ORIGINAL FIREPLACE MAY NEVER BE RETURNED TO SOLID FUEL USE IN THIS CONDITION.

IMPORTANT: If the factory-built fireplace has no gas access hole(s) provided, an access hole of 1.5 inch (37.5 mm) or less may be drilled through the lower sides or bottom of the firebox in a proper workmanship like manner. This access hole must be plugged with non-combustible insulation after the gas supply line has been installed. Cutting any sheet-metal parts of the fireplace, in which the gas fireplace insert is to be installed, except as tested for the floor is prohibited.

The included label plate shown below must be permanently attached inside the cavity of the fireplace in a visible location.

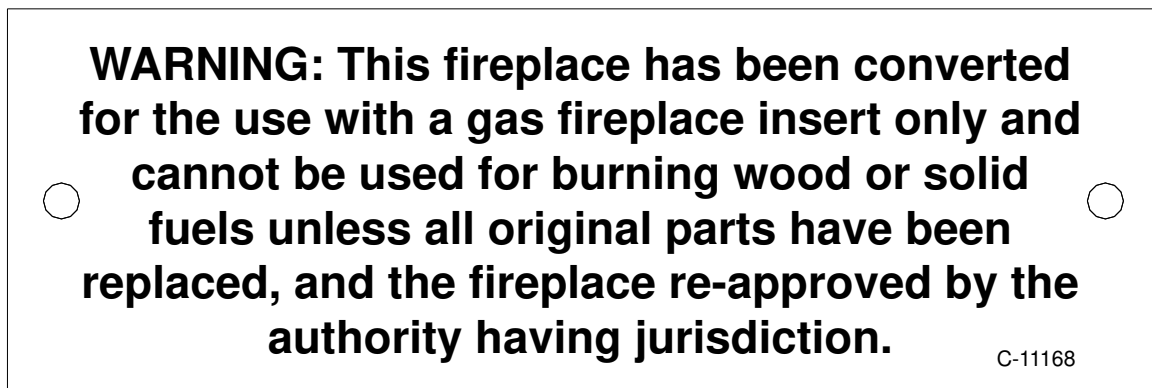

Figure 52: Fireplace Altered Plate.

ELECTRICAL REQUIREMENTS:

The fireplace must be electrically connected and grounded in accordance with local codes or, in the absence of local codes, with the current CSA C22.1 Canadian Electrical Code Part 1, Safety Standards For Electrical Installations, or The National Electrical Code ANSI / NFPA 70 in the US.

CAUTION: When servicing controls, label all wires prior to disconnection. Wiring errors can cause improper and dangerous operation. Verify proper operation after servicing.

If any of the original wire as supplied with the appliance must be replaced, it must be replaced with 18 AWG wire with a temperature rating of 105°C

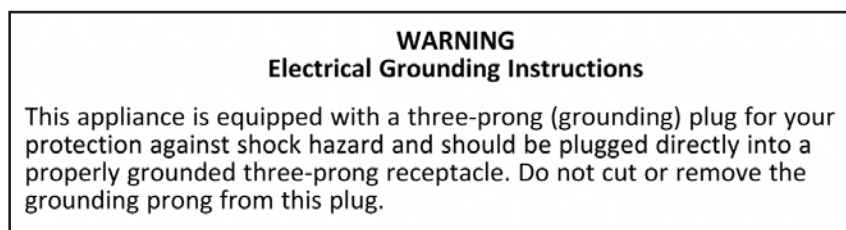

INITIAL INSTALLATION

QUALIFIED INSTALLERS ONLY

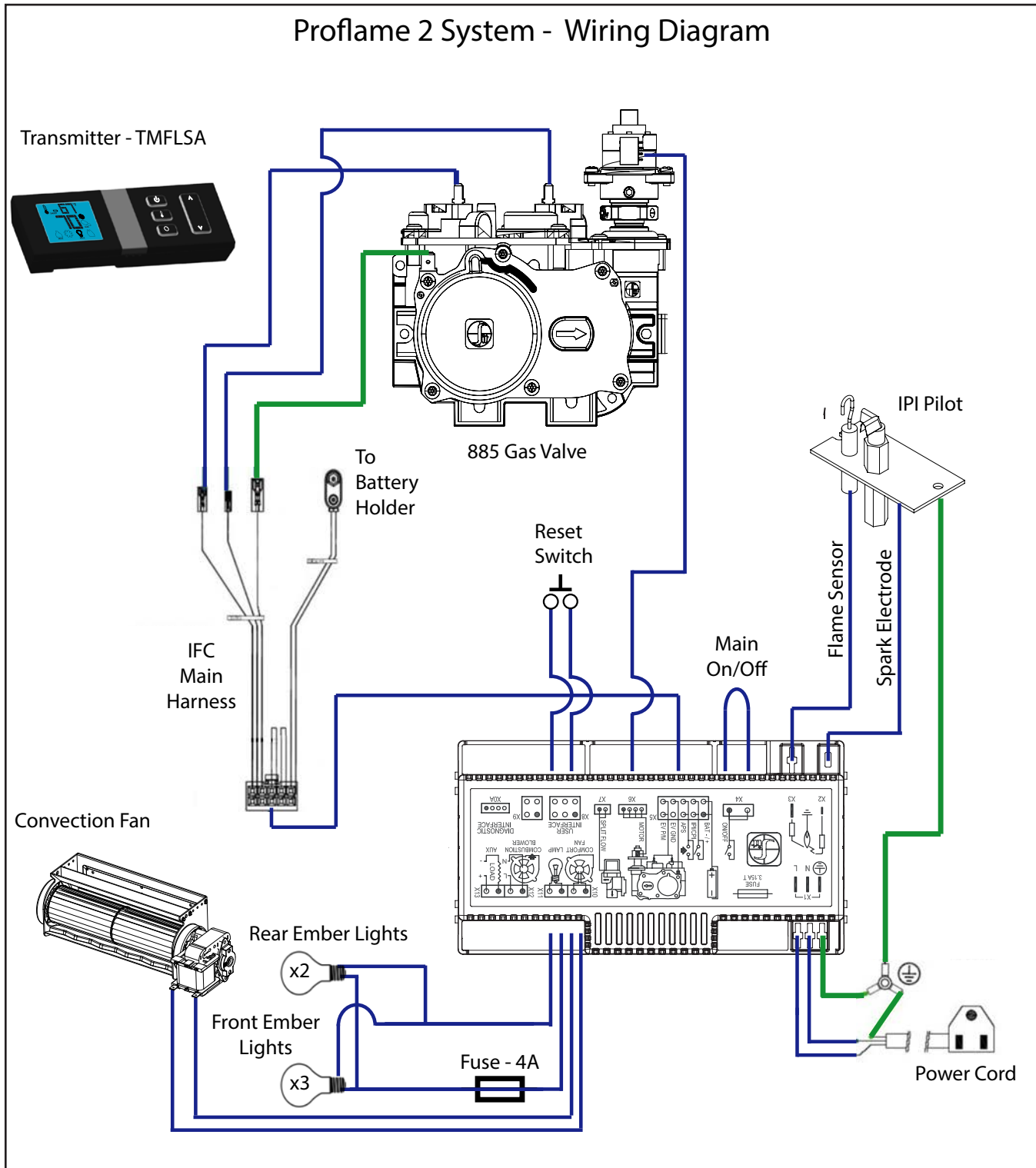

Figure 53: Wiring Schematic.

INITIAL INSTALLATION

QUALIFIED INSTALLERS ONLY

GAS LINE CONNECTION:

WARNING: Only persons licensed to work with gas piping may make the necessary gas connections to this appliance.

Gas Line Connection:

- Prior to installation consult your local authorities codes or the CAN/CGA B 149 (1 or 2) installation code in Canada, or in the USA gas installations follow either local codes or the current edition of the National Fuel Gas Code ANSI Z223.1.

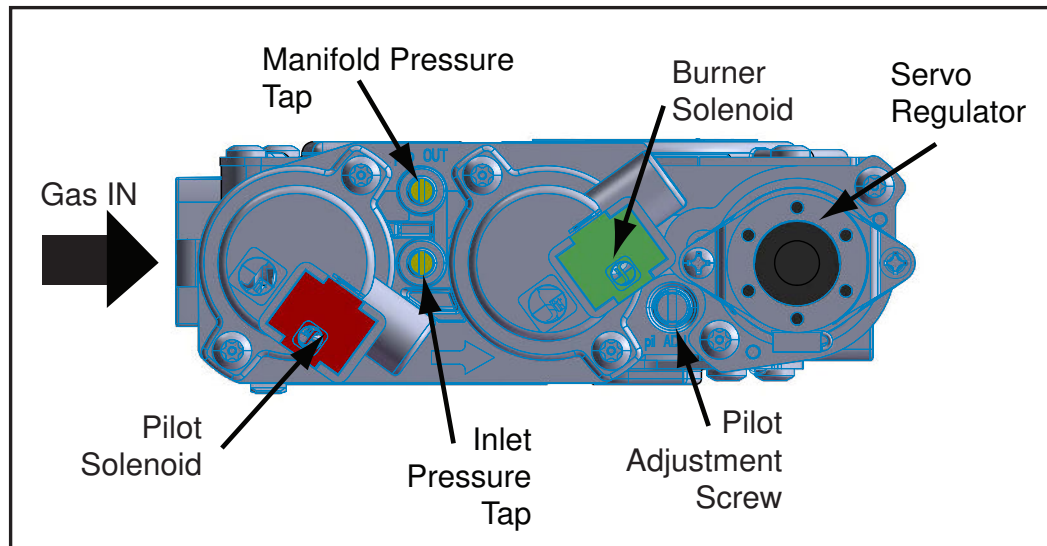

Figure 54: Fully Labeled Gas Valve.

The appliance must be disconnected from the gas supply piping system during any pressure testing where the pressure exceeds $\frac{1}{2}$ PSIG (3.45 KPa) or damage will occur to the valve. The appliance must be isolated from the gas supply piping system by closing its individual manual shutoff valve during any pressure testing of the gas supply piping system at test pressures equal to or less than $\frac{1}{2}$ psig (3.45 KPa).

Always check for gas leaks with a soap and water solution after completing the required pressure test.

TO TEST VALVE PRESSURES

The pressure taps are located on the valve shown in Figure 54.

- Turn set screw 1 turn counter clockwise to loosen,
- Place $\frac{5}{16}$ " (8 mm) I.D. hose over pressure tap system.
- Check pressures using a manometer.
- When finished, release pressure, remove hose & tighten set screw.

INITIAL INSTALLATION

QUALIFIED INSTALLERS ONLY

Table 9: Orifice and Pressure Information.

Ri30 Proflame Valve

Main Burner	Natural Gas	Propane Gas
Orifice:	2 x #51, 1 x #54 DMS	2 x #58, 1 x #63 DMS
Max. Manifold Press:	3.6 W.C. (0.89 KPa)	10.0" W.C. (2.49 KPa)
Min. Manifold Press:	1.6 W.C. (0.40 KPa)	6.4" W.C. (1.59 KPa)
Max. Supply Press:	7.0" W.C. (1.74 KPa)	11.0" W.C. (2.74 KPa)
Min. Supply Press:	4.5" W.C. (1.12 KPa)	10.4" W.C. (2.59 KPa)
Max. Input:	32,000 BTU/hr (9.38 KW)	32,000 BTU/hr (9.38 KW)
Min. Input:	21,000 BTU/hr (6.15 KW)	25,000 BTU/hr (7.33 KW)

NEVER USE AN OPEN FLAME FOR LEAK TESTING.

ADJUSTING THE PILOT FLAME:

The pilot flow adjustment is set to maximum at the factory and should not need to be adjusted. The pilot flame should envelope $\frac{3}{8}$ " to $\frac{1}{2}$ " (10 to 13mm) of the Flame sensor (see Figure 55). However, should the need arise, follow Steps 1- 2 below.

1. The adjustment screw can be reached through the front of the unit using a 10 inch long blade head screw driver (see Figure 54 for location on valve).
2. Turn the adjustment screw clockwise to decrease or counterclockwise to increase pilot flame.

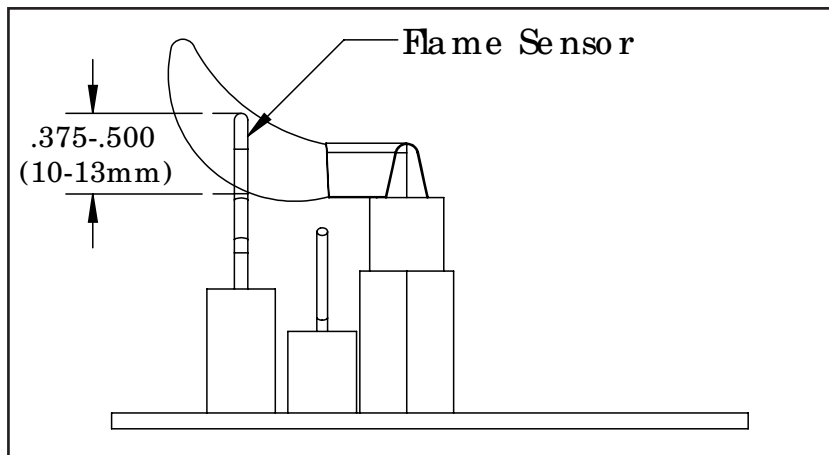

Figure 55: Proper Pilot Flame.

SECONDARY INSTALLATION

OPTIONAL BASE SHELF & RISER:

The optional Base Shelf (1⁵/₈" (41 mm) high) and Base Shelf Riser (2¹/₈" (54 mm) high) are components that can be combined to create a riser with an overall height of 2³/₁₆" (55 mm). This shelf can be installed with or without the riser and can be used when the hearth in front of the unit is lower than the fireplace opening. Additional Base Shelf Risers can be fastened together to increase the height in increments of 2¹/₈" (54 mm). This Base Shelf may be used in conjunction with the any surround panel options (excluding 4-sided), and it may also be used with the trimmable Surround. The Base Shelf and Riser are sold separately.

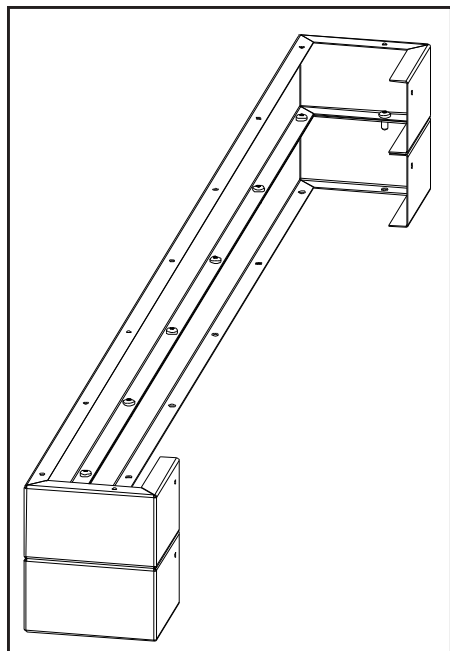

Figure 56: Combining 2 Base Shelf Riser.

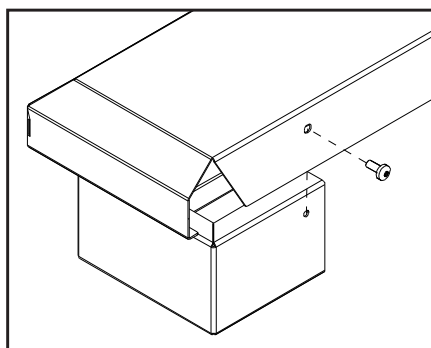

Figure 57: Installing Base Shelf onto Riser.

Installation:

1. If unit is running, turn it off and allow it to cool completely.
2. When using more than one riser each level must be attached using nine (9) #8 T-20 screws provided (see Figure 56).
3. If installing with riser(s) the Base Shelf is to be fastened to the riser(s) with one T-20 screw at each end of the back (see Figure 57).
4. The leveling legs may need to be adjusted to match the height of the riser and shelf.
5. Center the Base Shelf assembly in front of the unit flush with the bottom of the unit.
6. Install surround if required.

SECONDARY INSTALLATION

SURROUND PANEL INSTALLATION:

WARNING: The surround becomes hot when the unit is operating; ensure that the unit is turned off, and that it has cooled to room temperature before beginning this installation.

Please check components supplied with this kit. If components are missing or have been damaged, contact your dealer, distributor or courier company before starting this installation.

IMPORTANT: The panel must not seal ventilation openings in the fireplace.

INSTALLATION:

Lift the face upright in front of the fireplace with the four hooks pointing towards the fireplace. Slide the hooks into the slots on fireplace cabinet (see Figure 58). Ensure the hooks are secure before releasing the surround. The surround should be wiped with a damp cloth periodically.

REMOVAL:

Lift the surround straight up in order to unhook the notch on the hooks from the slots. Pull the surround away from the fireplace. Place the surround where it will not be damaged.

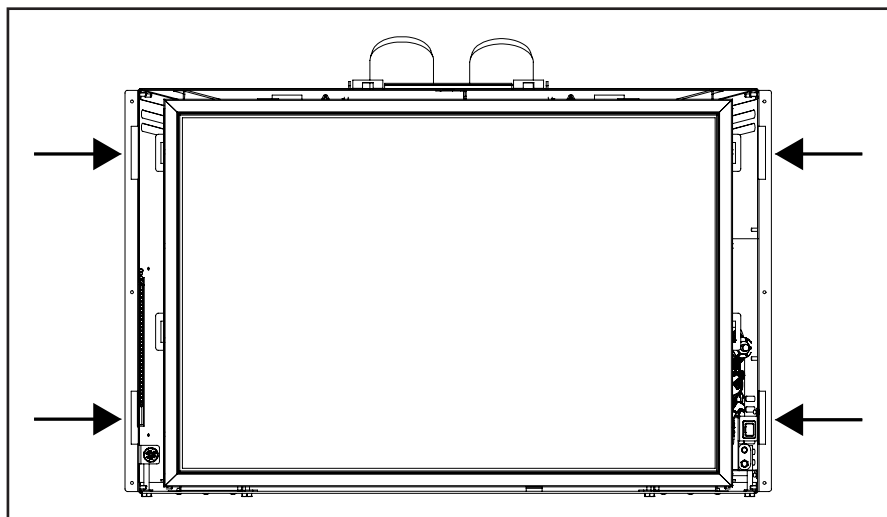

Figure 58: Slot Locations.

CLEANING:

NEVER CLEAN FACES WHEN THEY ARE HOT. Turn off fireplace and allow to fully cool.

Painted surfaces should be periodically wiped with a damp cloth. Plated surfaces must be free of fingerprints and smudges prior to installation and should be cleaned with a clean soft rag and a small amount of Isopropyl alcohol.

SECONDARY INSTALLATION

OPTIONAL TRIMMABLE PANELS:

Modifying the Surround Panel:

Trimmable Surround Panels are large rectangular panels that may be cut for use in cases that a non-standard fireplace opening (e.g. an arched opening) is to be filled. Optionally this surround can be left uncut and placed in front of the fireplace opening.

1. Measure the fireplace opening and/or make a template of the fireplace opening.
2. Transfer the measurement to the Trimmable Surround.
3. If desired, offset the measurements by approximately $1/8''$ (3mm) to the inside; this will allow for the panel to be placed just inside the fireplace opening for a cleaner appearance.
4. Cut along the preferred line (from direct measurements of offset) and remove any sharp edges.
5. The panel can be touched up with a high temperature metallic black paint available from your dealer.

INSTALLATION:

1. Install the two Trimmable Panel brackets onto the unit using a T-20 Torx screwdriver. See Figures 59-62. for the screw installation locations. There are two sets of hole patterns on cabinet side depending on which Surround Panel is being installed. See Figures and 62. Then attach the panel to the brackets (Figure 63).

NOTE: The Galiano, Slim, and Forgeworks Panels use the same holes for mounting the side cabinet brackets. The Contemporary Surround Panel uses its own set of holes.

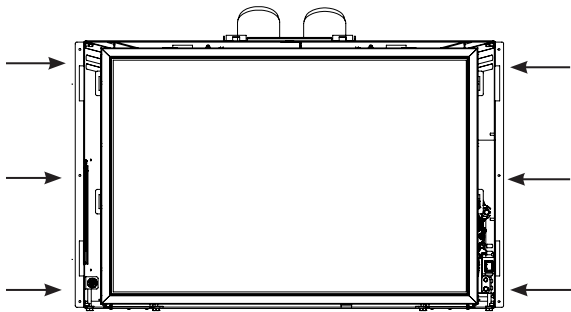

Figure 59: Screw Installation Locations.

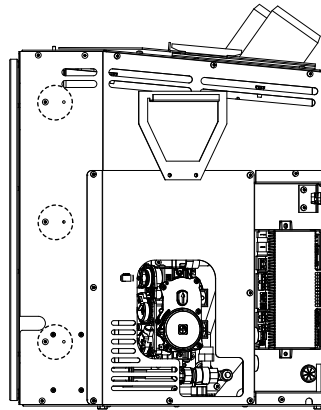

Figure 60: Screw Installation Locations.

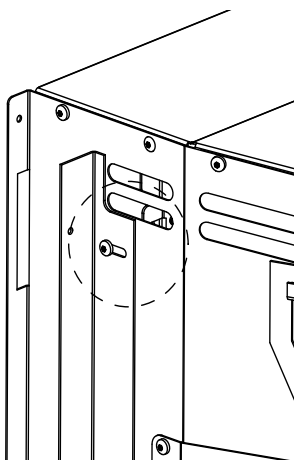

Figure 61: Installation for Contemporary.

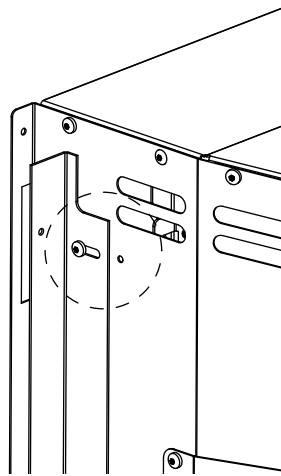

Figure 62: Installation for all other surrounds.

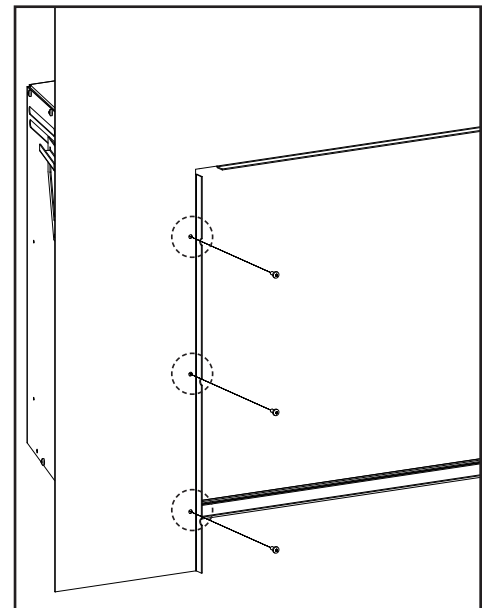

Figure 63: Screw Installation Locations.

SECONDARY INSTALLATION

LOG SET INSTALLATION:

The placement of the logs is not arbitrary. If they are positioned incorrectly, the flames can be “pinched” and will not burn correctly. Using the pictures provided, carefully set the logs and media in place.

NOTE: The logs are fragile and should be handled gently.

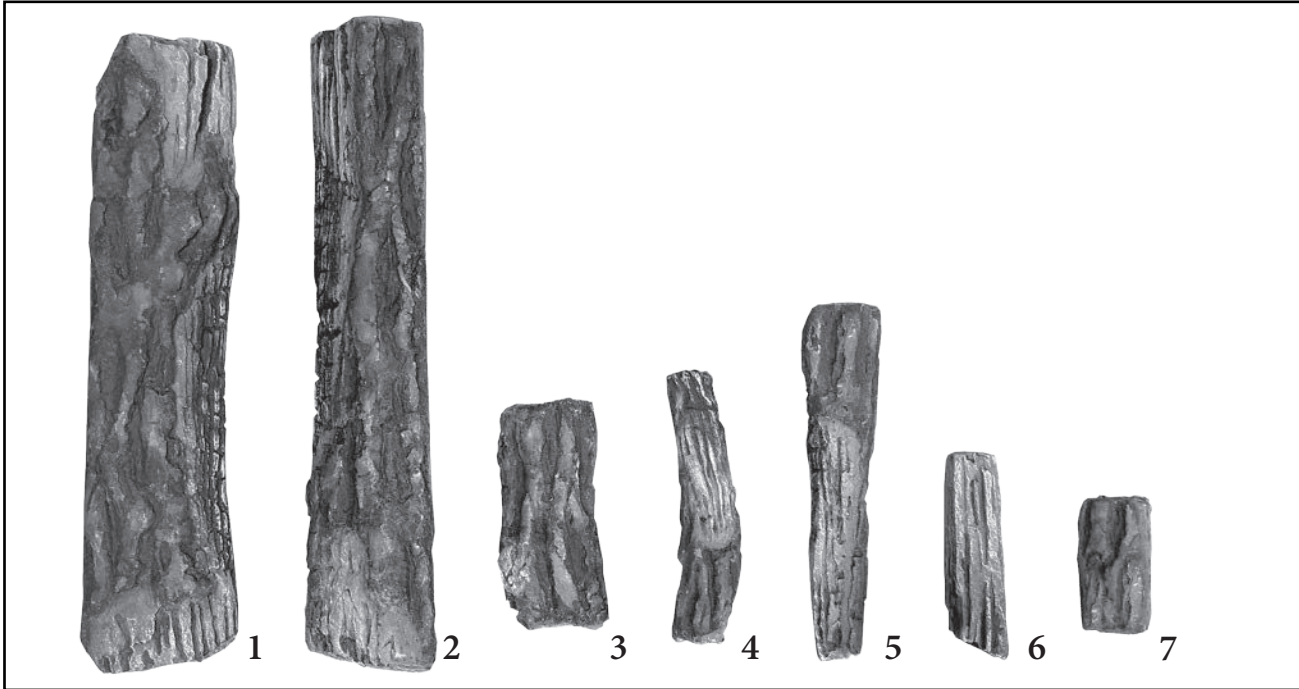
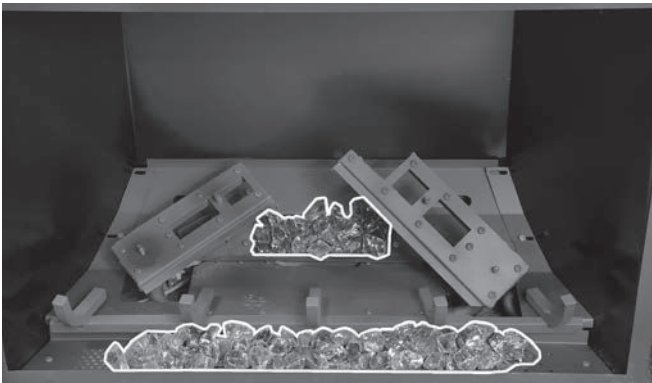

Figure 64: Ri30 Traditional Log Set

Please ensure that there is no damage to the log set and all 7 pieces are included prior to installation.

To Install Log Set:

1. Remove the safety screen from the unit. Then remove the glass door by releasing the top spring latches using the provided door tool.



2. Next, add the ember glass media by filling the rear ember tray first then using the rest of the media in the front tray. There should only be enough left to cover the center 3/4 of the tray.

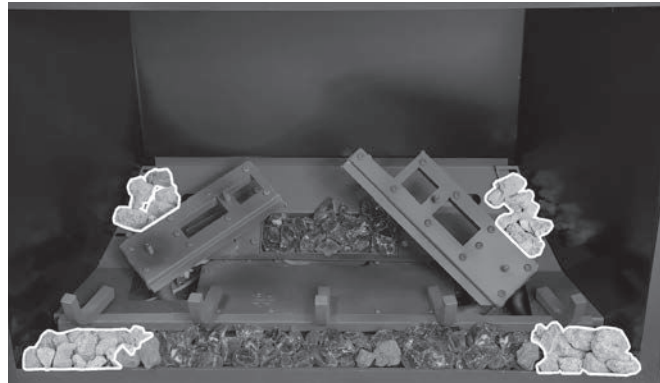

3. Fill the side gaps in the front ember tray with the lava rock provided. Then carefully place lava rock behind the two elevated burners as shown.

SECONDARY INSTALLATION

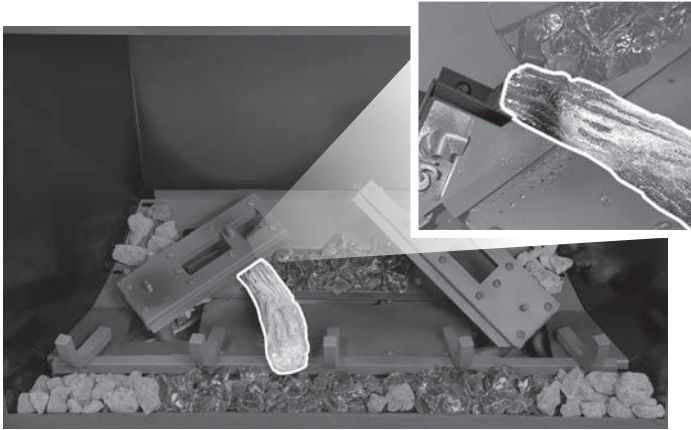

4. Place log 4 against the plate beneath the elevated burner next to the pilot.



5. Position log 3 on top of the center log grate and underneath the right elevated burner.



5. Place Log 1 on to the left elevated burner. Confirm that the log is aligned on the locating pins.



6. Place Log 2 on to the right elevated burner. Confirm that the log is aligned on the locating pins.



7. Fill in the gaps between the logs with the rest of the lava rock as shown.



8. Place log 5 underneath log 1 and on top of log 3, be careful not to place it too close to the right burner or it may cause sooting.

SECONDARY INSTALLATION



9. Place Log 8 the grate and on top of of log 4.



10. Place Log 7 on the log grate as shown.



Figure 65. Proper Installation & Flame Appearance

11. Re-install the firebox door, then the safety screen.
12. Run the unit for 15 minutes then adjust the venturi as needed. Figure 65 above depicts what the burn and flame appearance should look like when the log set is properly installed and venturi adjusted.

When re-lighting the fireplace for the first time since the log set has been installed/replaced, watch for ignition at ALL the burner ports. If a long delay is noticed, turn the appliance off and wait for it to cool down. Then remove the burner media and make sure none of the burner ports are blocked.

Maintenance: Once a year, the logs should be removed and checked for deterioration or large amounts of soot. A small amount on the bottom side of the logs is normal. Remove and replace the logs in the same manner described above.

If new logs are required, contact your nearest ENVIRO dealer.

Never operate the fireplace with the glass door removed.

TROUBLESHOOTING

Problem	Possible Cause	Solution	
Thermostat does not work	The pilot flame has gone out	· Turn it ON	
	The On/Off switch is turn to OFF		
	The thermostat is set too high	· Set the thermostat to a lower temperature	
No spark generation	Spark develops near the pilot assembly or could occur onboard	· Check pilot assembly wiring	
		· Check for broken or poor connection from the sparker to the electrode	
		· Check for the spark shorting or arcing at other locations	
		· Check for defective sparker and spark electrode	
No pilot flame ignition	No spark from the igniter	· See "no spark generation"	
	Air in the gas line	· It takes a while for all the air to purge out of the pilot before gas can reach the pilot and ignite	
	Pilot gas pressure dropout upon main burner gas valve opening	· Check gas mains supply and pressure	
	No gas flow out of the pilot burner	· Check gas valve wirings and connections to the board	
		· Check the pilot burner for obstruction	
· Check the wirings and connections between the pilot assembly and the board			
Pilot will not remain lit	7-Days of burner inactivity.	• The pilot will automatically turn off when the burner has not been used for 7 consecutive days. Re-light pilot to reset the counter.	
		Problem with Flame Sensor circuit	· Check for proper connection of the Flame Sensor to the IFC board
			· Check pilot for full flame impingement around Flame Sensor
			· If flame is too small, check gas pressure, adjust pilot rate screw, check pilot head for damage
	· Ensure the ground wire is properly attached to the pilot mounting bracket and that it is makes a good electrical connection.		
Restrictor setting	· Use the correct restrictor setting for the venting configuration		
Remote control (transmitter) does not work	The pilot light has gone out	· See "Pilot will not remain lit"	
	The transmitter is too far away from the heater	· Use the transmitter to the heater	
	The transmitter batteries are dead	· Replace the batteries	
No reaction to command	Transmitter batteries are low	· Replace the batteries	
	A maximum number of failed ignitions or flame restorations have been reached.	· Remove any possible blocking conditions. See "locking conditions"	
		· See how to reset the board from Lockout	
No communication between the remote control and the receiver	No communication between the remote control and the receiver	· Reprogram the transmitter to the receiver.	
		· Follow the initializing system for the first time	

TROUBLESHOOTING

Problem	Possible Cause	Solution
Locking conditions	Reset the Proflame IFC board	· Turn the system off by pressing the ON/OFF button on the transmitter
		· After approximately 2 seconds press the ON/OFF button on the transmitter again.
		· In the manual flame control mode, use the down arrow button to reduce the flame to off, indicated by the word OFF displayed on the transmitter LCD screen.
		· Wait approximately 2 seconds and press the up arrow button, the ignition sequence will start.
		· With the transmitter off, disconnect main power from stove for a few seconds then re-connect power.
		· Wait approximately 2 seconds and press the Reset button on the IFC
Main burners will not start	The pilot flame has gone out	· See "Pilot will not remain lit"
	The remote control is not working correctly	· Replace the batteries
	The thermostat is set too high	· Set the thermostat to a lower temperature
Flame lifting	Leak in vent pipe	· Check for leaks in vent connections
	Improper vent configuration	· Check vent configuration with manual
	Terminal may be re-circulating flue gases	· Check to see if terminal is on correctly
		· May need to install high wind termination cap.
Blue Flames	The heater has just been started	· Normal during start up: flame will yellow as the fireplace heats up
	Improper air shutter adjustment	· Adjust air shutter – contact your dealer
Glass fogs up	Normal condition: after the appliance warms up the glass will be clear.	**Due to additives in gas, glass may get hazy during operation** Clean as needed.
Flames are burning "dirty" or sooting	The logs or glasses are placed incorrectly	· Check log positioning
		· Check level of glasses layout
	Improper air shutter adjustment	· Increase primary air by opening the air shutter and/or by opening the vent restrictor
		· Check for proper venting and blockage of the vent termination
Incorrect rating input	· See also "Burners will not remain lit"	
		· Check manifold pressure and clock input rating for over-firing

PARTS LIST

#	Parts Description	Part #
1	Fan only	50-3901
2	Ri30 Flue Adaptor	50-4665
3	Ri30 Flue Adaptor Gasket	50-4666
4	Ri Door Spring Latches (set of 2)	50-4667
5	Door Release Tool	50-2510
6	Flue Adaptor Tool	50-3505
7	SIT IPI Valve	50-2682
8	Battery Holder 4 x AA	50-3027
9	Proflame 2 Remote - Wall Mount	50-3028
-	Proflame 2 IFC Wire Harness (0.584.045)	50-3030
10	Proflame 2 IFC	50-4103
11	PSE IPI Pilot Assembly	50-4058
-	IPI LP Pilot Thimble	50-4080
-	4 AMP Glass Fuse	50-2076
14	Ri30 Door Complete	50-4676
-	Ri30 Door Glass	50-4677
-	Dual Bulb Door Gasket 10ft	50-634
15	Safety Screen	50-4089
16	Safety Screen Complete	50-4699
17	Ri30 Base Burner	50-4669
18	Ri30 Left Burner	50-4670
19	Ri30 Right Burner	50-4671
-	Orifice #51 Long (NG Main Burners)	50-4577
-	Orifice #54 Long (NG Base Burner)	50-4583
-	Orifice #58 Long (LP Main Burners)	50-4681
-	Orifice #63 Long (LP Base Burner)	50-4682
20	Ri30 Steel Baffle	50-4678
21	Ri30 Back Tray Assembly	50-4668

#	Parts Description	Part #
22	Ri30 Rear Light Cover	50-4672
23	Ri30 Rear Light Assembly	50-4673
24	Ri30 Front Light Cover	50-4674
25	Ri30 Front Light Assembly	50-4675
-	Halogen Socket With Wires	50-4632
-	35W Halogen Bulb	50-3291
25	Log Grate	50-2907
26	Ri30 Base Orifice Mount (with gas line)	50-4679
27	Ri30 Main Burner Oriface Mount (with gas line)	50-4680
28	Ri30 Steel Liner	50-4683
	Ri30 Brick Liner	50-4684
	Ri30 LedgeStone Liner	50-4685
	Ri30 Herringbone Liner	50-4686
-	Ri30 Porcelain Liners	50-4694
-	Ri30 Galiano Surround	50-4687
-	Ri30 Contemporary Surround	50-4688
-	Ri30 Slim Surround	50-4689
-	Ri30 Forgeworks Face	50-4690
-	Ri30 Trimable Filler Panel	50-4691
-	Ri30 Tradional Log Set	50-4692
-	Ri30 Birch Log Set	50-4693
-	NG to LP Stepper Motor Only	50-3753
-	LP to NG Stepper Motor Only	50-3870
-	Ri30 Owners Manual	50-4700
-	12 oz. Can of Metallic Black Touch Up Paint	PAINT 12-MB

PARTS DIAGRAM - COMPONENTS

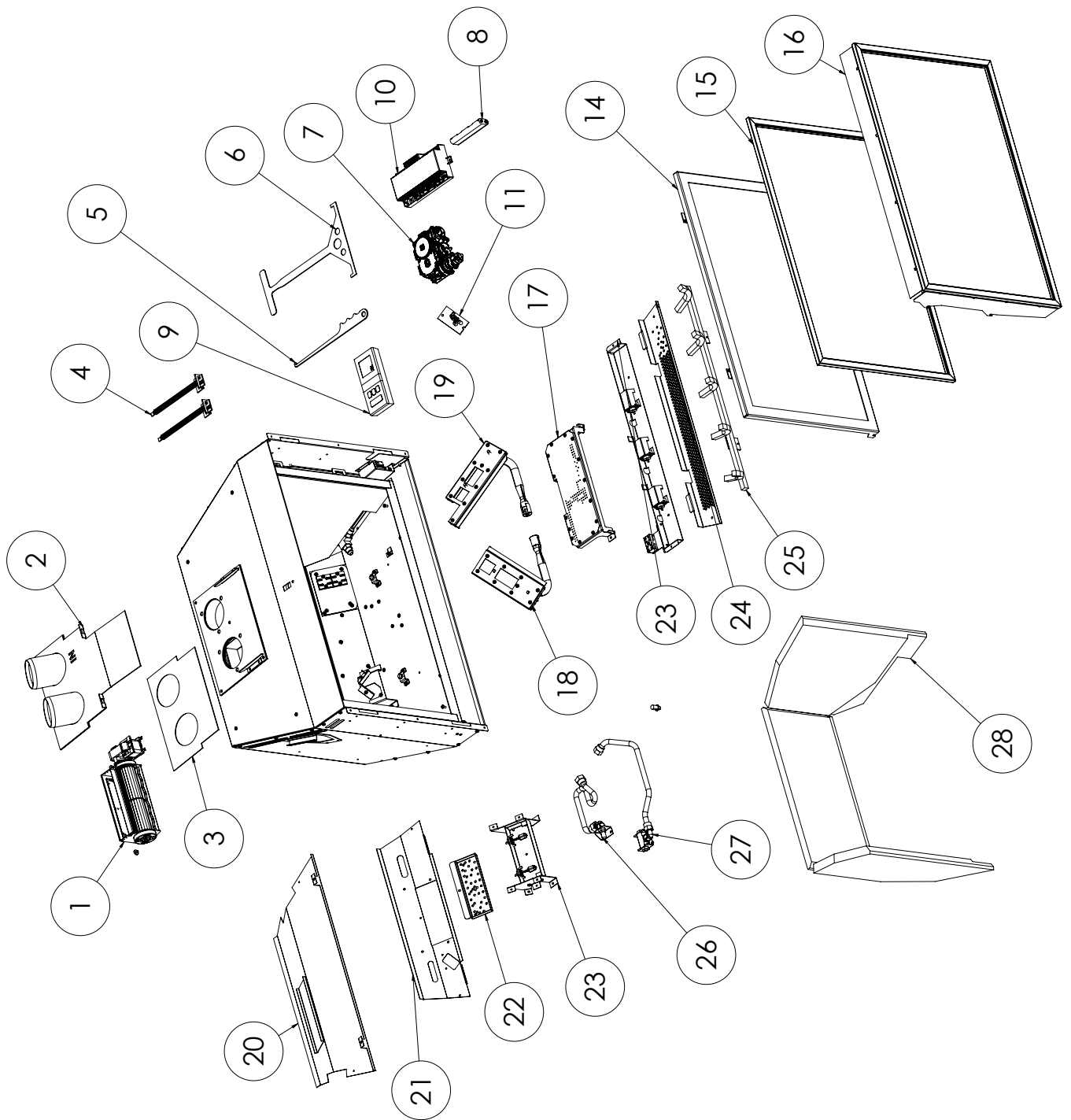



Warranty for Enviro Gas Products

Sherwood Industries Ltd. ("Sherwood") hereby warrants, subject to the terms and conditions herein set forth, this product against defects in material and workmanship during the specified warranty period starting from the date of original purchase at retail. In the event of a defect of material or workmanship during the specified warranty period, Sherwood reserves the right to make repairs or to assess the replacement of a defective product at Sherwood's factory. The shipping costs are to be paid by the consumer. All warranties by Sherwood are set forth herein and no claim shall be made against Sherwood on any oral warranty or representation.

Conditions

- A completed warranty registration must be submitted to Sherwood within 90 days of original purchase via the online warranty registration page or via the mail-in warranty registration card provided. Have the installer fill in the installation data sheet in the back of the manual for warranty and future reference.
- This warranty applies only to the original owner in the original location from date of install.
- The unit must have been properly installed by a qualified technician or installer, and must meet all local and national building code requirements.
- The warranty does not cover removal and re-installation costs.
- Sherwood Industries Ltd. reserves the right to make changes without notice.
- Sherwood Industries Ltd. and its employees or representatives will not assume any damages, either directly or indirectly caused by improper usage, operation, installation, servicing or maintenance of this appliance.
- A proof of original purchase must be provided by you or the dealer including serial number.
- This warranty does not cover any discoloration of the safety screen mesh.

Exclusions

An expanded list of exclusions is available at www.enviro.com/help/warranty.html

This warranty does not cover:

- Damage as a result of improper usage or abuse.
- Damage caused from over-firing due to incorrect setup or tampering.
- Damage caused by incorrect installation.

To the Dealer

- Provide name, address and telephone number of purchaser and date of purchase.
- Provide date of purchase. Name of installer and dealer. Serial number of the appliance. Nature of complaint, defects or malfunction, description and part # of any parts replaced.
- Pictures or return of damaged or defective product may be required.

To the Distributor

- Sign and verify that work and information are correct.

Sherwood Industries Ltd.

6782 Oldfield Road, Victoria, BC . Canada V8M 2A3
 Online warranty registration: www.enviro.com/warranty/

Category	One Year	Two Year	Limited Lifetime (7yr)
Parts ^{1,2} (unit serial number required)		✓	
Firebox Liner Panels ³		✓	
Firebox			✓
Heat Exchanger			✓
Burner			✓
Ceramic Logs ⁴			✓
Ceramic Glass ⁵	✓		
Pedestal / Legs (excluding finish)			✓
Door Assembly			✓
Surround Panels (excluding finish)			✓
Exterior Panels (excluding finish)			Up to 5 years
Electrical Components		✓	
Exterior Surface Finishing	✓		
Labour	✓		

¹ Whereas warranty has expired, replacement parts will be warranted for 90 days from part purchase date. Labour not included. Unit serial number required.

² 50-173 Westport Fan Kit covered for up to 5 years from purchase date. Labour not included. Unit serial required.

³ Excluding damage to the finish caused by improper setup of the appliance, or color changes.

⁴ Log set and panels excludes wear and tear or breakage caused by cleaning or service.

⁴ Glass is covered for thermal breakage. Photos of box, inside of door, and unit serial # must be supplied for breakage due to shipping.

⁶ Exterior Surface finishing covers plating, enamel or paint and excludes colour changes, chipping, and fingerprints. Travel costs not included.

NOTES

INSTALLATION DATA SHEET

The following information must be recorded by the installer for warranty purposes and future reference.

NAME OF OWNER:

ADDRESS:

PHONE: _____

NAME OF DEALER:

ADDRESS:

PHONE: _____

MODEL: _____
SERIAL NUMBER: _____
DATE OF PURCHASE: _____ (dd/mm/yyyy)
DATE OF INSTALLATION: _____ (dd/mm/yyyy)
 DIRECT VENT
 NATURAL GAS (NAT) PROPANE(LPG)
INLET GAS PRESSURE: _____ in WC
MAIN BURNER ORIFICE: _____ # DMS
PILOT ORIFICE # _____ OR _____ in diam.
INSTALLER'S SIGNATURE:

NAME OF INSTALLER:

ADDRESS:

PHONE: _____

MANUFACTURED BY:
SHERWOOD INDUSTRIES LTD.
6782 OLDFIELD RD. SAANICHTON, BC, CANADA V8M 2A3
www.enviro.com
February 2025
C-17181